

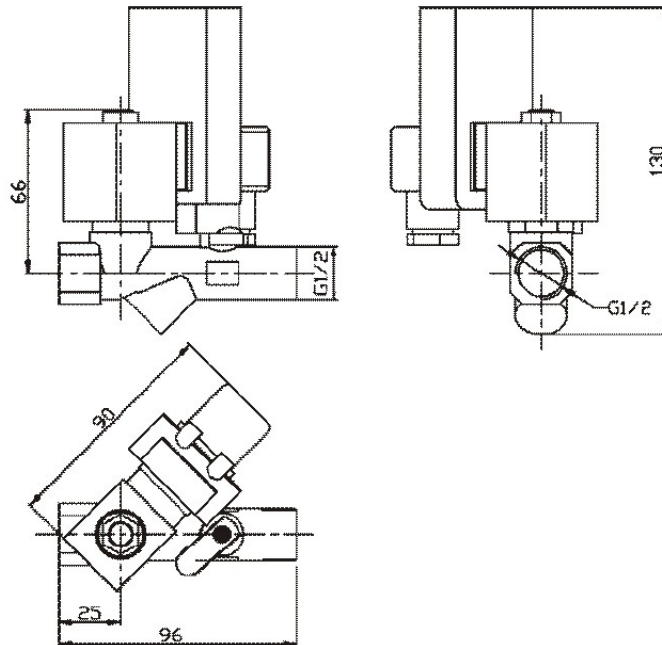

DRAIN MANUAL CONTENTS

- Technical Data
- Installation Information
- Parts Information



CAG Purification 3770B Unit 2, Laird Road, Mississauga, Ontario
Tel: 800-951-0777 Fax: 905-820-3490
www.cagpurification.com sales@cagpurification.com



Product Description

TSD-719 timed electric drain consists of a timer, solenoid valve, coil, din connector, gaskets, 10’ power cord with three pronged plug. A ball valve c/w y-strainer is also included and installed as standard.

Timer Technical Data

Interval Time Off Min	0.5 – 45 minutes adjustable
Discharge Time On Sec	0.5 – 10 seconds adjustable
Supply Voltage	115/1/60 Hz (other voltages available)
Voltage Tolerance	+ or – 10%
Manual Test Switch	standard
Current	4mA
Switch Capacity:	1A
Operating Temperature	-20°C to +80°C
Protection Class	IP65, NEMA 4 installed
Timer Case Material	FR Grade ABS Plastic Flame-proof
Connection	DIN43650A ISO4400/6952
Indicators	Yellow valve open or closed
Approval	QPS inspection to CSA special inspection guideline SPE1000-13

Valve Technical Data

Valve Type	2/2 way direct acting
Connection Ports In / Out	1/2” npt male to 1/2” npt female
Maximum Working Pressure	232 psig
Operating Temperature	2°C to 80°C
Maximum Fluid Temperature	90°C
Valve Construction	brass
Orifice Size	3.5 mm
Seal	NBR, Viton
Protection	IP65
Supply Voltage	115/1/60 Hz (other voltages available)
Voltage Tolerance	+ or – 10%
Coil	H grade
Mounting Configuration	any
Approval	QPS inspection to CSA special inspection guideline SPE1000-13

TSD Product Function

The TSD-719 timed electric drain is designed to drain condensate from air compressors, moisture separators, receiver tanks, filters, air dryers and drop legs in a compressed air system. The timer will control condensate drainage at any interval between the adjustable time cycles from 0.5 to 45 minutes. The draining time can be set between 0.5 to 10 seconds.

Installation Service and Maintenance Information

CAUTION. FOR INSTALLER SAFETY PLEASE ENSURE THE COMPRESSED AIR SYSTEM HAS BEEN COMPLETELY VENTED AND IS UNDER NO PRESSURE AND ALL ELECTRICAL POWER IS OFF BEFORE INSTALLING DRAIN.

When installing the TSD drain valve insure the valve direction shown on valve body is correct and the condensate will discharge in the same direction as the arrow shown on the valve body. Please ensure the ball valve strainer is installed on the inlet side of the drain in order to protect and maintain the drain. The drain valve may be installed in any configuration. An oil/water separator is recommended on the discharge side of the drain valve. This will allow for separation and clean condensate being discharged in order to meet the sewer use by-law. The drain is generally maintenance free but we recommend replacing parts every few years. The test button may be used to test drain as required. Parts are available from CAG Purification Inc.

Timer Setting

Set Interval Time OFF: MIN adjustment knob on right side of timer face. Set Discharge Time ON: SEC adjustment knob on left side of timer face. Normal setting is 2 seconds ON: SEC knob and 10 to 20 minutes OFF: MIN knob. In order to prevent unnecessary power consumption, draining and wear and tear the user may adjust timer for best results as required.

Replacement Part Numbers

Timer	T-719	Timer/Din Gasket	TG-719
Coil	SC-719	Timer/Coil Gasket	CG-719
Valve	V-719	Valve Nut	VN-719
Din Connector	DN-719	Din Connector Screw	DS-719
Power Cord/Plug	PC-719	Ball Valve Strainer	CYS-S95