



EN-US - english US

Instructions for installation and operation

Emulsion splitting plant

BEKOSPLIT[®] 14S (BS 14S)

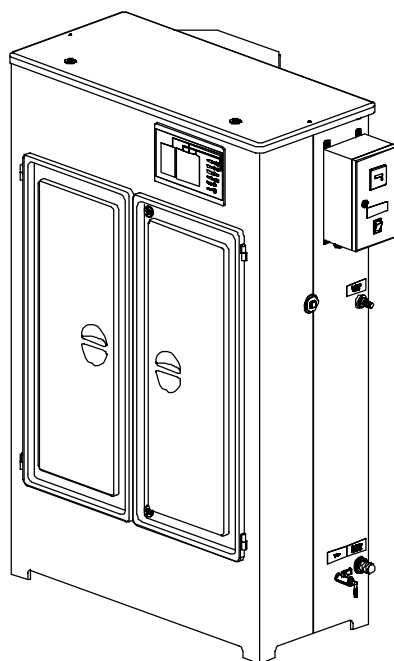

Dear customer,

Thank you for deciding in favor of the BEKOSPLIT® 14S emulsion splitting system. The operating instructions describe the BEKOSPLIT® 14S splitting unit including a preseparation container with oil separation. Please read these installation and operating instructions carefully before mounting and starting up the system, and follow our directions. Perfect functioning, and thus reliable condensate processing, can only be guaranteed when the provisions and notes stipulated hereinafter are strictly adhered to.





1	Type plate	4
2	Pictograms and symbols	5
3	Signal words in accordance with ISO 3864 and ANSI Z 535	7
4	General advice	7
5	Safety instructions	8
5.1	General safety instructions	8
5.2	Special safety instructions	9
5.3	Process-depending dangers	9
6	Proper use	11
7	Exclusion from the scope of application	11
8	Technical data	12
9	Dimension drawing	13
10	Function	15
11	Installation	16
12	Electrical installation	20
13	Start-up	25
14	Operation	29
14.1	Dosage setting	31
15	Control and maintenance	32
16	Fault elimination	36
17	Elements and components	40
18	Wearing parts	41
19	Spare parts	41
20	Accessories	42
21	Dismantling and disposal of the plant	42
22	National technical approval	43
23	Declaration of conformity	44

Type plate

1 Type plate

The type plate is at the housing. It includes all the important data of the BEKOSPLIT® 14S which must be communicated to the manufacturer or supplier upon request.

Never remove, damage or obliterate the type plate!

BEKOSPLIT® 14S	
Code	Code 2800108 ES120C005 (example)
Serial number	Serial number 11341590 (example)
Year of construction	Year of construction 2011 (example)
Max. plant capacity	Max. plant capacity 90 l/h
Max. compressor performance	Max. compressor performance 75 m³/h
Reference turbidity	Reference turbidity 20 mg/l (example)
Supply voltage	Supply voltage 230VAC, 50-60 Hz
Frequency	Frequency 50 – 60 Hz
Power supply output	Power supply output 24 VDC
Max. power input	Max. power input < 100 VA
Ambient temperature	Ambient temperature +41 ... +122 °F
Weight	Weight approx. 54 kg (119 lb)
 BEKO TECHNOLOGIES GMBH http://www.beko-technologies.com Made in Germany    	

2 Pictograms and symbols



General danger symbol (danger, warning, caution)



General danger symbol (danger, warning, caution) for compressed air and plant components under pressure



General danger symbol (danger, warning, caution) for supply voltage and supply voltage-carrying plants components



General danger symbol (danger, warning, caution) for explosive substances



General danger symbol (danger, warning, caution) regarding the automatic start-up of rotating agitator parts
Never reach into this zone



No smoking



General advice



Observe the installation and operating instructions



Use eye protection



Wear light breathing protection

Pictograms and symbols



Wear protective gloves



Special maintenance instructions



Condensate inlet at the tank



Condensate outlet at the tank



Direction of rotation of the dosing feeder



Service note regarding the hose pump



Service note regarding the motors

3 Signal words in accordance with ISO 3864 and ANSI Z 535

Danger!	Imminent hazard Consequences of non-observance: serious injury or death
Warning!	Potential hazard Consequences of non-observance: possible serious injury or death
Caution!	Imminent hazard Consequences of non-observance: possible injury or property damage
Notice!	Potential hazard Consequences of non-observance: possible injury or property damage
Important!	Additional advice, info, hints Consequences of non-observance: disadvantages during operation and maintenance, no danger

4 General advice



Please check whether or not these instructions correspond to the device type.

Adhere to all advice given in these operating instructions. They include essential information which must be observed during the installation, operation and maintenance. Therefore it is imperative for the service technician and the responsible operator / technical staff to read these operating instructions prior to installation, start-up and maintenance.

The operating instructions must be accessible at any time at the place of application of the BEKOSPLIT® 14S.

In addition to these operating instructions, local or national regulations must be complied with, if necessary.

Make sure that the BEKOSPLIT® 14S is operated only within the permissible limit values indicated on the type plate. Any deviation involves a risk for persons and materials, and may result in malfunction and service failures.

If you have any queries regarding these installation- and operating instructions, please contact BEKO TECHNOLOGIES CORP.



For safe operation, the plant must only be operated and maintained in accordance with the indications in these operating instructions. In addition, the national and operational statutory provisions and safety regulations, as well as the accident prevention regulations required for the respective case of application, need to be observed during the employment. This applies accordingly when accessories are used.

Non-observance of the installation and operating instructions involves risks for persons, systems, and the environment.

As regards the electrical installation, observe all regulations in force (e.g. VDE 0100 / IEC 60364).

Electrical works must only be carried out by authorized and skilled personnel!



System performance tests, installation, setting and maintenance measures must only be carried out by authorized and skilled personnel. Only instructed personnel are authorized to carry out settings during the operation.

The dosage setting of the BEKOSPLIT® 14S must, as a matter of principle, only be implemented by authorized and skilled personnel.

Use original BEKO TECHNOLOGIES reaction splitting agents and filters only! (Not included in the scope of delivery).

Check the outflowing cleaned water once a week by means of a reference turbidity!

Safety instructions



Do not fill any foreign liquid into the preseparation container of the BEKOSPLIT® 14S, as this may impair the splitting process!

The BEKOSPLIT® 14S and the preseparation container must only be transported when empty! Due to continuous technical development, we reserve the right to implement necessary modifications without prior notice.

If you have any queries regarding these instructions, please contact BEKO TECHNOLOGIES GMBH.

5 Safety instructions

5.1 General safety instructions



DANGER!

Supply voltage!

The operation and maintenance of electrically-powered plants and devices must only be undertaken by correspondingly qualified and authorized personnel. Prior to carrying out maintenance works, no matter which type, the following notes must be considered:

Measures:

- Make sure that no parts of the plant are energized, and that they cannot be connected with the electric supply mains during servicing.
- The device must not be started up if the power lines are damaged.
- The BEKOSPLIT® 14S must not be operated if parts of the housing were removed.



DANGER!

Missing grounding!

When the grounding (protective ground) is missing, there is the risk in the event of malfunction, that contactable, conductive components may carry supply voltage. Touching of such parts leads to an electric shock with injury and death.

Measures:

- Observe all regulations in effect during electrical installation (e.g. VDE 0100 / IEC 60364).
- Carry out maintenance works only when the device is de-energized.
- It is imperative to ground the plant and the device, or the equipment grounding conductor must be connected in accordance with the provisions.
- Any electrical works must only be carried out by authorized and skilled personnel .



Warning!

Unauthorized interventions!

Unauthorized interventions may endanger persons and plants and lead to malfunction.

Any modification of the plant or of the function parameters that has not been checked and approved by the manufacturer is potentially dangerous.

Measures:

- System performance tests, installation, setting and maintenance measures must only be carried out by authorized and skilled personnel.
- The dosage setting of the BEKOSPLIT® 14S must, as a matter of principle, only be implemented by authorized and skilled personnel.

5.2 Special safety instructions



NOTE!

Ambient conditions!

In the event of external overheating, parts of the plant can be destroyed.

Observe the permissible storage and transport temperature, as well as the permissible operating and ambient temperature.

Protect the plant against direct sunlight and heat.

Do not install the plant in areas where frost is likely to occur or outdoors!

5.3 Process-depending dangers



CAUTION!

Harmful hydrocarbons!

Harmful hydrocarbons may exist in the ductwork.

For example:

- Hydrocarbons and other particles which are toxic or dangerous to health in another manner.
- Particles which are contained in high-temperature gases.

Measures:

- As long as the process conditions are not absolutely safe, corresponding precautions, such as the use of a respiratory mask or the purging/detoxification of the ductwork, need to be taken prior to any intervention into the ductwork for maintenance or installation purposes.
- Ensure that the duct system is pressureless before any installation or dismantling works are carried out. In the event that you are not sure in some cases, please check with your local safety representative and/or read the local safety regulations.



CAUTION!

Harmful dusts!

The used splitting agent can rise when being filled into the plant and cause dust which can be irritant and dangerous to health.



Measures:

- It is recommended to use light breathing protection, eye protection and protective gloves for any works with the splitting agent.



CAUTION!

Release of dangerous substances!

The BEKOSPLIT® 14S must only be operated with condensate from compressed air that is free from aggressive, corrosive, caustic, toxic, flammable and fire-accelerating constituents.

Safety instructions



CAUTION!

Filling-in inadmissible liquids!

Inadmissible liquids can lead to health hazards and poisoning.

The BEKOSPLIT® 14S is only intended for condensate from compressed-air compressors. Other liquids can be aggressive, corrosive, caustic, toxic, or flammable, and contain fire-accelerating constituents. In addition, harmful gases may be released.



CAUTION!

Flapping hoses!

Hoses which are not fixed and secured can make strong flapping movements in the event of compressed-air surges and can, therefore, lead to injuries.



WARNING!

Dust explosion through splitting agents!

Dispersed dust particles of the splitting agents can form explosive mixtures which, in the event of ignition, can lead to severe injury and death.



Measures:

- During all works with splitting agents, it is imperative to avoid dispersion!
- Smoking and open fire prohibited!

6 Proper use

- The emulsion splitting plant serves to process emulsified compressor condensates in accordance with the legal stipulations.
- The operation of the emulsion splitting plant is subject to approval! Use the enclosed manual "Application/approval procedure" for the application.
- Do not fill any foreign liquid into the preseparation container, as this may impair the splitting process!
- Use original BEKO TECHNOLOGIES reaction splitting agents and filters only! (Not included in the scope of delivery)
- Do not exceed the performance data! (see Chapter "Technical data"). During a short-term overload/malfunction, the accumulated condensate is buffered in the preseparation container.
- Protect the plant against direct sunlight and heat.
- Do not install the plant in places where frost is likely to occur or outdoors!
- Special applications are possible. It is imperative to check the application beforehand with BEKO TECHNOLOGIES.
- The BEKOSPLIT® 14S must not be installed in hazardous areas, and must not be charged with explosive media.



Warning!

EMPLOYMENT TO PREVENT DANGEROUS CONDITIONS!

The unverified and sole employment of the BEKOSPLIT® 14S to prevent dangerous conditions at machines and plants can lead to exactly these conditions and cause injury and damage to plants and the environment.



CAUTION!

Improper use!

The BEKOSPLIT® devices offer state-of-the-art technology and are operationally safe. Residual risks may emanate from the devices when improperly employed and operated by untrained personnel.

7 Exclusion from the scope of application

- The BEKOSPLIT® 14S is **not** suitable for employment in ex-areas.
- The BEKOSPLIT® 14S must not be exposed to long-term direct sunlight or thermal radiation.
- The BEKOSPLIT® 14S must not be installed or operated in areas with an aggressive atmosphere.
- The BEKOSPLIT® 14S is not heatable and, therefore, is not suitable for employment in areas where frost is likely to occur.
- The BEKOSPLIT® 14S is not suitable for strongly alkaline and caustic liquids.

Technical data

8 Technical data

Max. throughput capacity	90 l/h
Max. compressor performance	75 m³/h
Filling volume reactor	22 l
Filling volume preseparation container	Separate preseparation tank
Filling volume splitting-agent container	25 l
Filling volume oil receiver	Depending on the preseparation tank 10 or 20 l
Filling volume filter bag	60 l
Wet weight filter bag	ca. 60 - 65 kg
Water outlet (hose)	G1" (d = 25 mm) internal
Empty weight	approx. 54 kg (119 lb)
Min./max. storage, transport, media and ambient temperature	+41 ... +122 °F
Supply voltage	230VAC, 50-60 Hz
Output voltage power supply unit	24 VDC
Max. power consumption	< 100 VA
Relay contact rating	> 5 VDC / > 10 mA < 50 VAC/DC / < 5A / < 150 VA/W
Fusing power supply unit	3.15 A / T (slow)
Degree of protection power supply unit	IP 54

Preseparation container	600 liters	1,000 liters
Container volume	600 l	1,000 l
Max. operating pressure at the inlet	25 bar *	25 bar *
Condensate feed line (hose)	3 x G½ (d _i = 13 mm)	3 x G½ (d _i = 13 mm)
Oil outlet	d _i = 32 mm	d _i = 32 mm
Oil receiver	10 l	20 l
Empty weight	Approx. 56 kg	Approx. 74 kg
Min./max. storage, transport, media and ambient temperature	+5 ... +50 °C	+5 ... +50 °C

* For higher pressure: use a high-pressure relief chamber

9 Dimension drawing

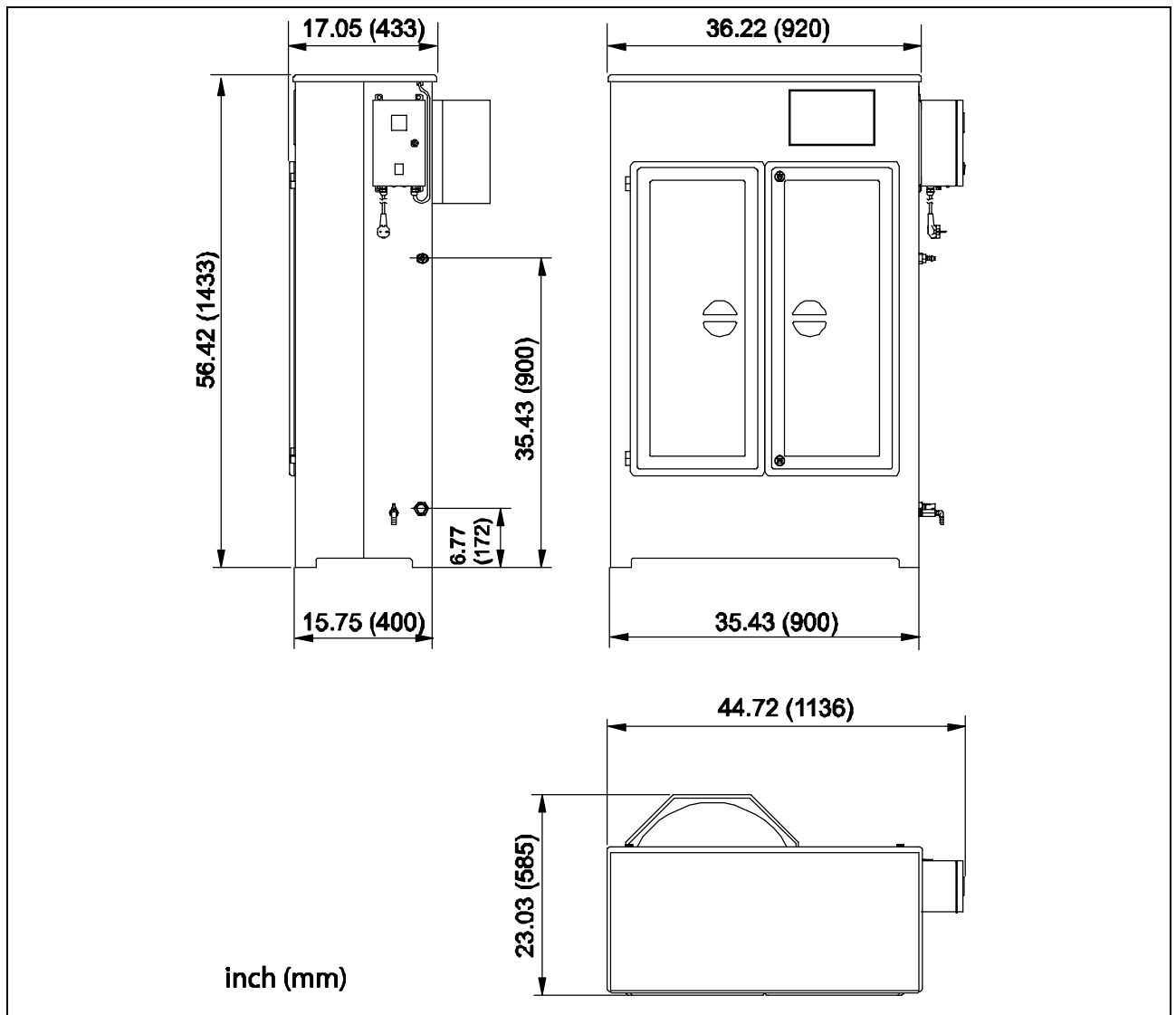

The dimensions are not warranted characteristics and are subject to tolerance in accordance with DIN ISO 2768-m.

Dimension drawing

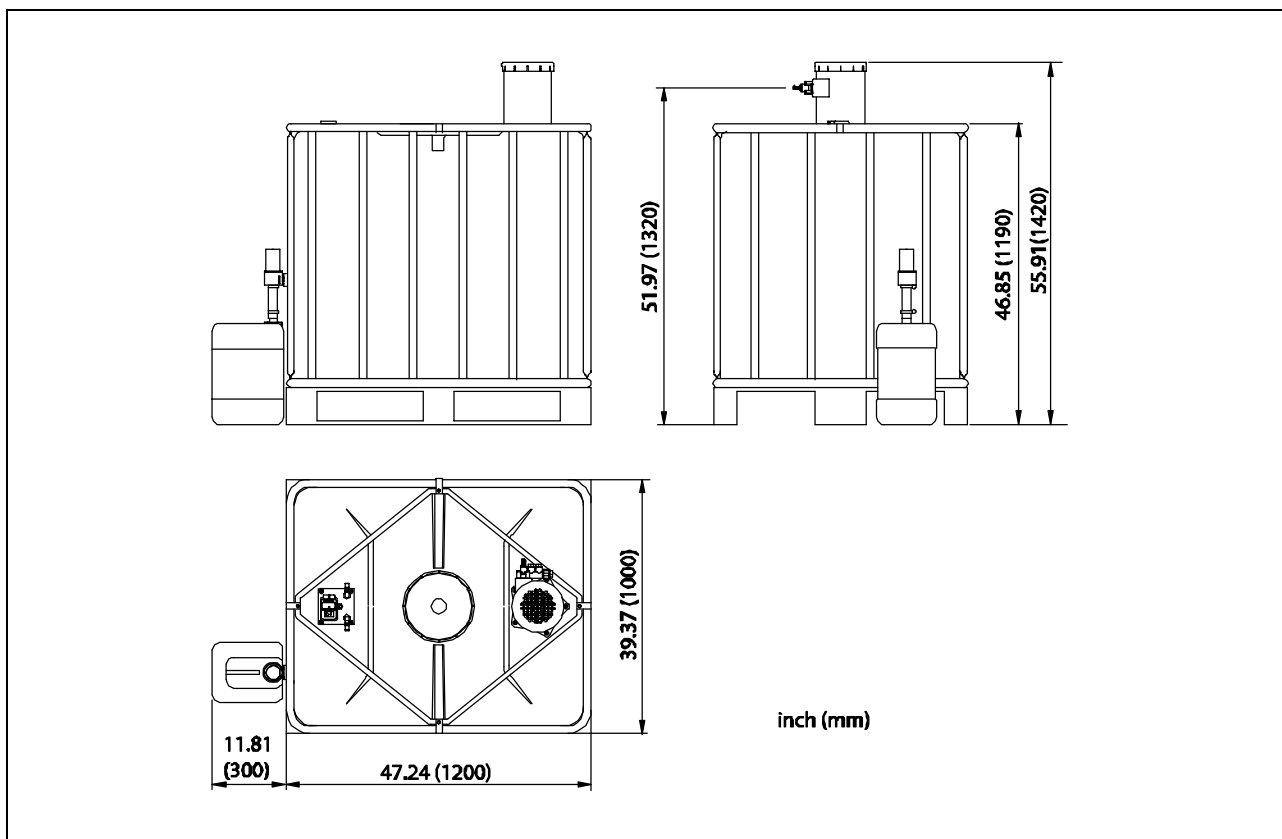

The dimensions are not warranted characteristics and are subject to tolerance in accordance with DIN ISO 2768-m

10 Function

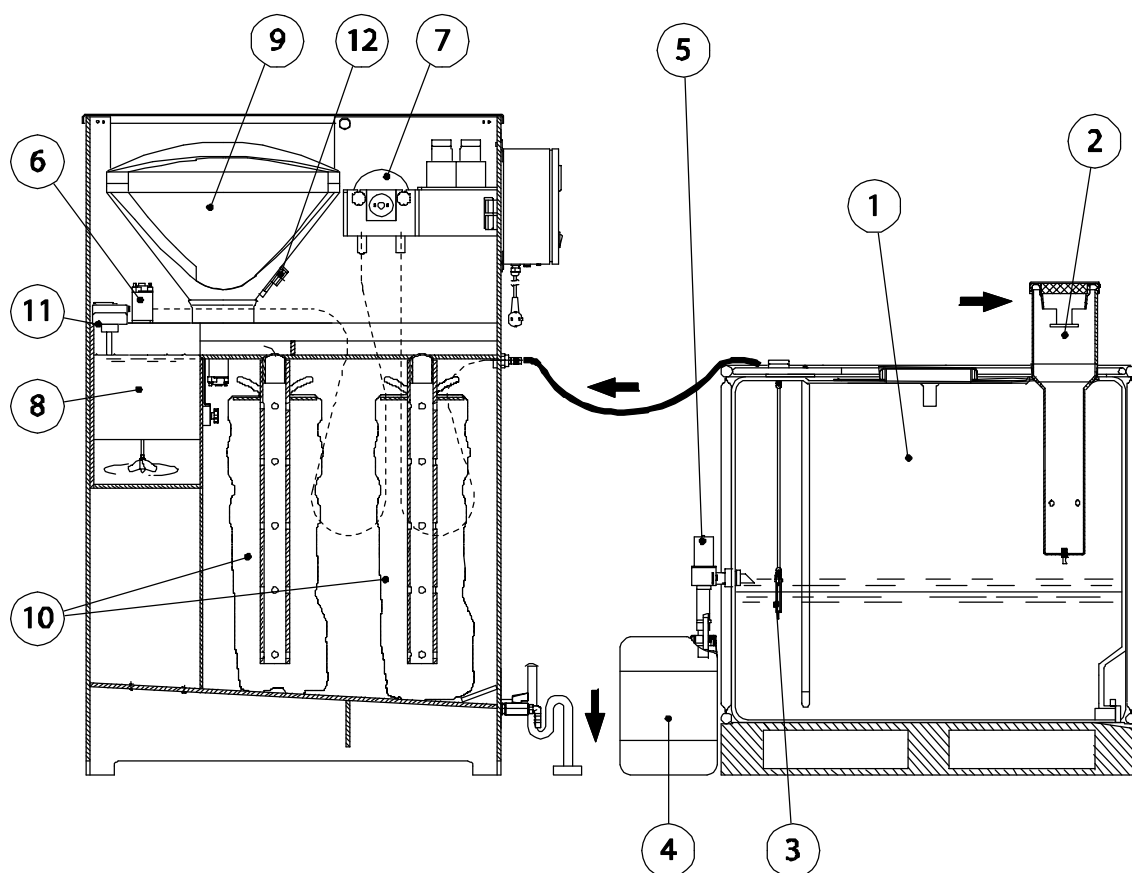

The oil-containing condensate can be supplied under pressure to the BEKOSPLIT® 14S. The overpressure is relieved in the pressure relief chamber (2) without causing turbulences in the pre-separation container (1).

Free oils rise and form an oil layer above the emulsion. The filling-level monitoring of the pre-separation container and the START signal transmission to the BEKOSPLIT is implemented by means of a capacitive START sensor (3). This sensor (3) only detects the emulsion and is installed approximately 3 cm below the oil outlet. Free oils float on the emulsion that is to be detected by the START sensor, reach the oil outlet with the increasing filling level of the pre-separation container, and can be led into the oil receiver (4).

When the emulsion filling level reaches the START sensor, the solenoid valve (5) at the oil outlet will close and the batchwise splitting process will begin. The agitator (6) starts, and the hose pump (7) supplies emulsion from the pre-separation container into the reaction tank (8). During the splitting process, a defined amount of reaction release agent is added to the emulsion in a time-controlled manner via the dosing unit (9), and distributed by the agitator through continuous circulation.

The oil and dirt constituents that were split off are encapsulated by the reaction release agent, and well filterable flakes are formed, which flow into the filter bag (10) via a discharge channel. The water that flows off can be supplied to the wastewater system.

The filling level of the filters is monitored with a capacitive sensor (11).

When the filter is filled, the processed wastewater can no longer flow off via the filter. The sensor detects the rising water level in the filter, channel, and reaction tank, and a maintenance message is released. If the filter is not replaced, the wastewater will flow into filter bag 2 via a weir in the channel. If this bag is also filled, the still rising wastewater level will be detected by the sensor and a trouble indication will be released which leads to a standstill of the BEKOSPLIT® 14S.

Another sensor (12) monitors the filling level of the dosing unit. If reaction release agent is no longer available, a trouble indication is released which also leads to the standstill of the BEKOSPLIT® 14S.

The trouble indication and maintenance message can be tapped as a potential-free signal via an indicator relay.

Installation

The fully automatic operation is controlled via the electronic unit. All necessary control and signal functions are integrated into this unit. The plant is started up through the enabling signal of the START sensor.

11 Installation



For safe operation, the plant must only be operated and maintained in accordance with the indications in these operating instructions. In addition, the national and operational statutory provisions and safety regulations, as well as the accident prevention regulations required for the respective case of application, need to be observed during the employment. This applies accordingly when accessories are used.

Non-observance of the installation and operating instructions involves risks for persons, systems, and the environment.

As regards the electrical installation, observe all regulations in force (e.g. VDE 0100 / IEC 60364).

Electrical works must only be carried out by authorized and skilled personnel!



System performance tests, installation, setting and maintenance measures must only be carried out by authorized and skilled personnel. Only instructed personnel are authorized to carry out settings during the operation.

The dosage setting of the BEKOSPLIT® 14S must, as a matter of principle, only be implemented by authorized and skilled personnel.

Use original BEKO TECHNOLOGIES reaction splitting agents and filters only! (Not included in the scope of delivery).

Check the outflowing cleaned water once a week by means of a reference turbidity!



Warning!

Unauthorized interventions!

Unauthorized interventions may endanger persons and plants and lead to malfunction.

Any modification of the plant or of the function parameters that has not been checked and approved by the manufacturer is potentially dangerous.

Measures:

- System performance tests, installation, setting and maintenance measures must only be carried out by authorized and skilled personnel.
- The dosage setting of the BEKOSPLIT® 14S must, as a matter of principle, only be implemented by authorized and skilled personnel.



Danger!

Filling-in inadmissible liquids!

Inadmissible liquids can damage health and lead to poisoning.

The BEKOSPLIT® is only intended for condensate from compressed-air compressors. Other liquids can be aggressive, corrosive, caustic, toxic, or flammable, and contain fire-accelerating constituents. In addition, harmful gases may be released.



NOTE!

Ambient conditions!

In the event of external overheating, parts of the plant can be destroyed.

Observe the permissible storage and transport temperature, as well as the permissible operating and ambient temperature.

Protect the plant against direct sunlight and heat.

Do not install the plant in areas where frost is likely to occur or outdoors!



CAUTION!

Harmful hydrocarbons!

Harmful hydrocarbons may exist in the ductwork.

For example:

- Hydrocarbons and other particles which are toxic or dangerous to health in another manner.
- Particles which are contained in high-temperature gases.

Measures:

- As long as the process conditions are not absolutely safe, corresponding precautions, such as the use of a respiratory mask or the purging/detoxification of the ductwork, need to be taken prior to any intervention into the ductwork for maintenance or installation purposes.
- Ensure that the duct system is pressureless before any installation or dismantling works are carried out. In the event that you are not sure in some cases, please check with your local safety representative and/or read the local safety regulations.



CAUTION!

Release of dangerous substances!

The BEKOSPLIT® 14S must only be operated with condensate from compressed air that is free from aggressive, corrosive, caustic, toxic, flammable and fire-accelerating constituents.



CAUTION!

Flapping hoses!

Hoses which are not fixed and secured can make strong flapping movements in the event of compressed-air surges and can, therefore, lead to injuries.



DANGER!

Compressed air!

Risk of serious injury or death through contact with quickly or suddenly escaping compressed air or through bursting plant components.



NOTE:

Do not feed condensate until the start-up was completed!

Hoses must always be fixed in such a manner that they do not make flapping movements and thereby lead to injuries and/or damage.

During the installation, the legal provisions need to be adhered to.

The following points need to be observed in particular:

- Move the BEKOSPLIT® 14S and the preseparation containers only when empty, and with suitable means of transportation (e.g. on pallets).
- The BEKOSPLIT® 14S is top-heavy. Watch for protruding parts.

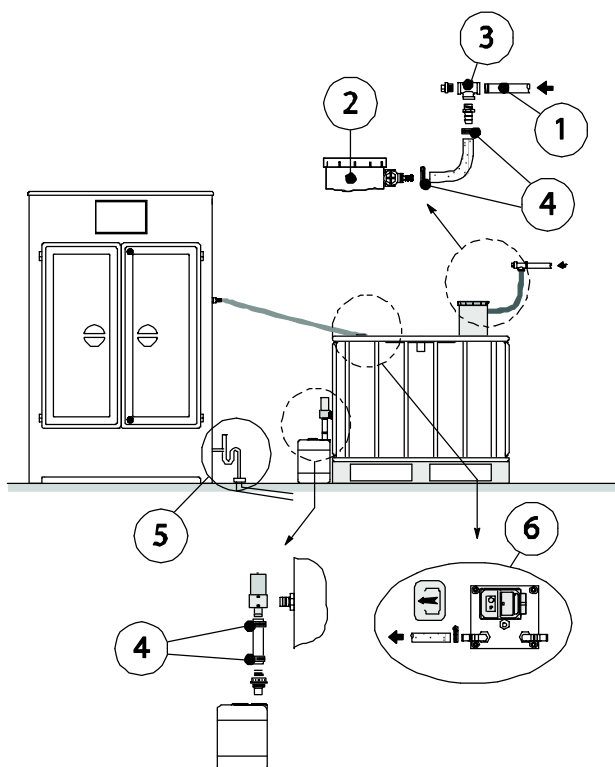

Area of installation

- Do not install in places where frost is likely to occur or outdoors!
- Sealed floor area or collection basin! In the event of damage, untreated condensate or oil must not leak into the sewerage system or the soil!
- Install the BEKOSPLIT® 14S horizontally on an even, smooth floor.
- Tightly screw the oil receiver to the oil drain of the preseparation container using the included connection kit.

Inlet

- Install the condensate manifold (1) > G1 with a slight downward slope to the preseparation container at the wall, use the T-piece (3) as a branch, and connect with the condensate inlet of the pressure relief chamber (2) via hose line. (Installation height of the line higher than the condensate inlet of the pressure relief). The lines must be secured against loosening, for example by means of hose clamps (4).
- Connect preseparation tank and BEKOSPLIT® 14S using the ½" hose supplied.

Outlet

- Fix the water drain hose at the water outlet of the BEKOSPLIT® 14S, and supply to the wastewater connection with a constant slope. Use a siphon as an odour trap.

12 Electrical installation



For safe operation, the plant must only be operated and maintained in accordance with the indications in these operating instructions. In addition, the national and operational statutory provisions and safety regulations, as well as the accident prevention regulations required for the respective case of application, need to be observed during the employment. This applies accordingly when accessories are used.

Non-observance of the installation and operating instructions involves risks for persons, systems, and the environment.

As regards the electrical installation, observe all regulations in force (e.g. VDE 0100 / IEC 60364).

Electrical works must only be carried out by authorized and skilled personnel!



System performance tests, installation, setting and maintenance measures must only be carried out by authorized and skilled personnel. Only instructed personnel are authorized to carry out settings during the operation.

The dosage setting of the BEKOSPLIT® 14S must, as a matter of principle, only be implemented by authorized and skilled personnel.

Use original BEKO TECHNOLOGIES reaction splitting agents and filters only! (Not included in the scope of delivery).

Check the outflowing cleaned water once a week by means of a reference turbidity!



DANGER!

Supply voltage!

The operation and maintenance of electrically-powered plants and devices must only be undertaken by correspondingly qualified and authorized personnel. Prior to carrying out maintenance works, no matter which type, the following notes must be considered:

Measures:

- Make sure that no parts of the plant are energized, and that they cannot be connected with the electric supply mains during servicing.
- The device must not be started up if the power lines are damaged.
- The BEKOSPLIT® 14S must not be operated if parts of the housing were removed.



DANGER!

Missing grounding!

When the grounding (protective ground) is missing, there is the risk in the event of malfunction, that contactable, conductive components may carry supply voltage. Touching of such parts leads to an electric shock with injury and death.

Measures:

- Observe all regulations in effect during electrical installation (e.g. VDE 0100 / IEC 60364).
- Carry out maintenance works only when the device is de-energized.
- It is imperative to ground the plant and the device, or the equipment grounding conductor must be connected in accordance with the provisions.
- Any electrical works must only be carried out by authorized and skilled personnel.

The BEKOSPLIT® 14S splitting plant is ready for connection. The supply voltage 110 ... 230 VAC / 50-60 Hz (see type plate) is provided via a cable with a safety plug.

Internal components are supplied via a power supply unit with an output voltage of 24 VDC.

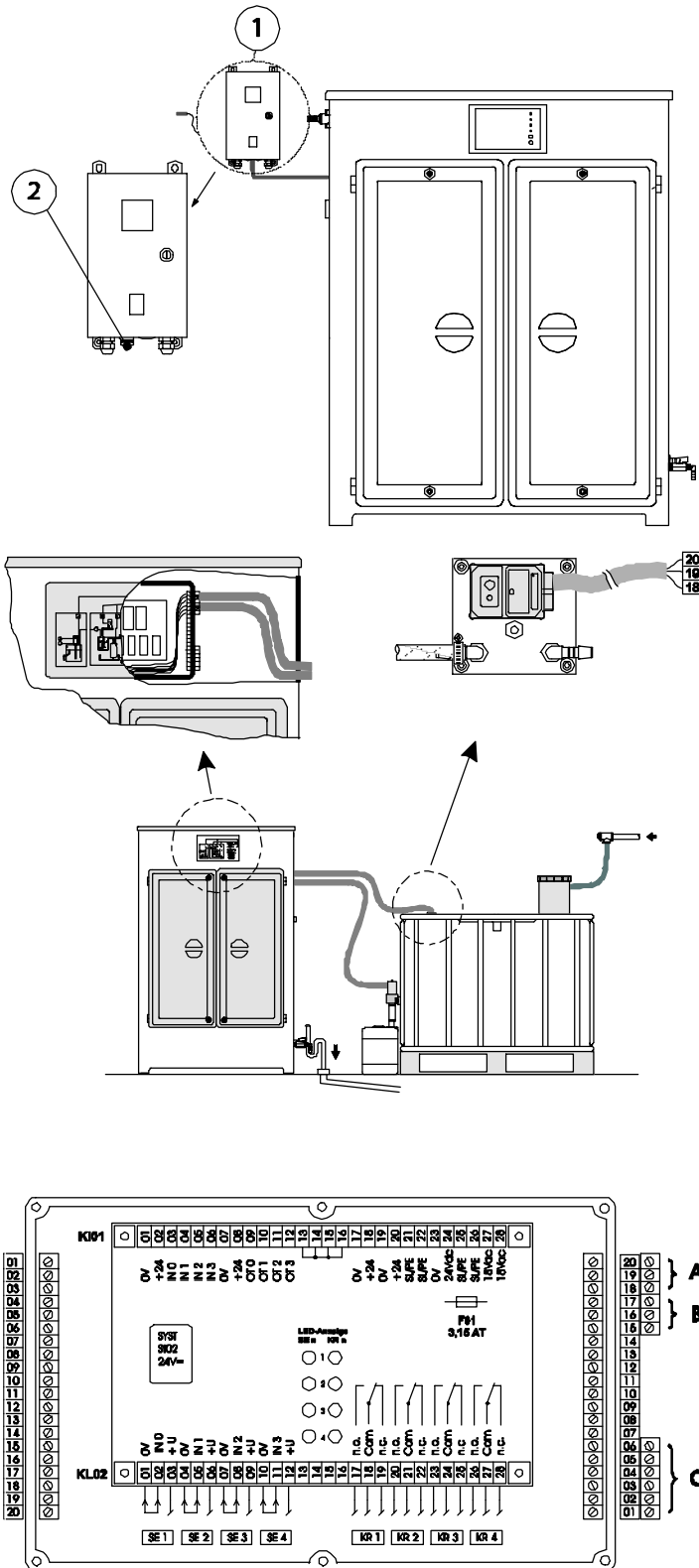

Installation power supply unit box

During the transport, the power supply unit box is at the splitting unit.

To allow the complete disconnection from the network, the power plug must be visible and well accessible.

Carry out installation works, e.g. VDE 100 / IEC 60364.

For the start-up and during operation, the doors and covers need to be kept closed.

Electrical installation

The BEKOSPLIT® 14S is ready for connection. The voltage supply $U = \dots \text{VAC}/50\text{-}60\text{Hz}$ is implemented via a cable with a safety plug (permissible voltage see type plate).

Internal components are supplied with a voltage of 24 VDC via a power supply unit.

- Connect the signaling cable for START sensor **A** according to the terminal assignment plan.
- Connect the cable for the oil drain valve **B** according to the terminal assignment plan.

Signal connections BEKOSPLIT

For external wiring, four signal inputs and four potential-free relay contacts are available.

The relay contacts may optionally be used as a normally closed contact or as a normally open contact; the connections are led to the outside via plug strip **C** at the control housing.

For the installation, remove the protective caps of the front panel, unscrew the screws, and remove the cover of the housing.

Plug-in connections at the control housing are exclusively suitable for the extra-low voltage range.

Electrical installation

Pos. KL02	Connec- tion	Designation	
28 27 26	n.c. com n.o.	Trouble indication fail-safe mode	Relais KR4 Relay KR4
25 24 23	n.c. com n.o.	Maintenance message fail-safe mode	Relais KR3 Relay KR3
22 21 20	n.c. com n.o.	Control of an external pump	Relais KR2 Relay KR2
19 18 17	n.c. com n.o.	Operability splitting unit	Relais KR1 Relay KR1
16 15 14 13			
12 11 10	+U IN3 0V	Input: external trouble indi- cation	SE4
09 08 07	+U IN3 0V	Input: external mainte- nance message	SE3
06 05 04	+U IN3 0V	Input: short test (customer service)	SE2
03 02 01	+U IN3 0V	Input: external start signal	SE1

For external wiring, a STOP/AUTO input (SE1) is available.

An external contact for the plant control can be connected to this input.

Close the contact -> AUTO mode
Open the contact -> STOP mode

Relay KR1 (C) stand-by

Terminal 19: normally closed contact

Terminal 18: centre contact

Terminal 17: normally open contact

When the supply voltage is applied and the BEKOSPLIT is in stand-by in the AUTO mode (start sensor uncovered), relay KR1 is operative. The contact (terminals 17-18) is closed.

Without supply voltage, in the STOP mode, or during the function in the AUTO mode, relay KR1 drops out. The contact (terminals 17-18) is open.

Relay KR2 control ext. pump

Terminal 22: normally closed contact

Terminal 21: centre contact

Terminal 20: normally open contact

This relay can be used, depending on the BEKOSPLIT® 14S configuration, to trigger an external pump.

For further information, see the instruction leaflet "safety container".

KR3 maintenance message

Terminal 25: normally closed contact

Terminal 24: centre contact

Terminal 23: normally open contact

Via this potential-free contact, a maintenance status signal can be transmitted. The change-over contact is operated in fail-safe mode.

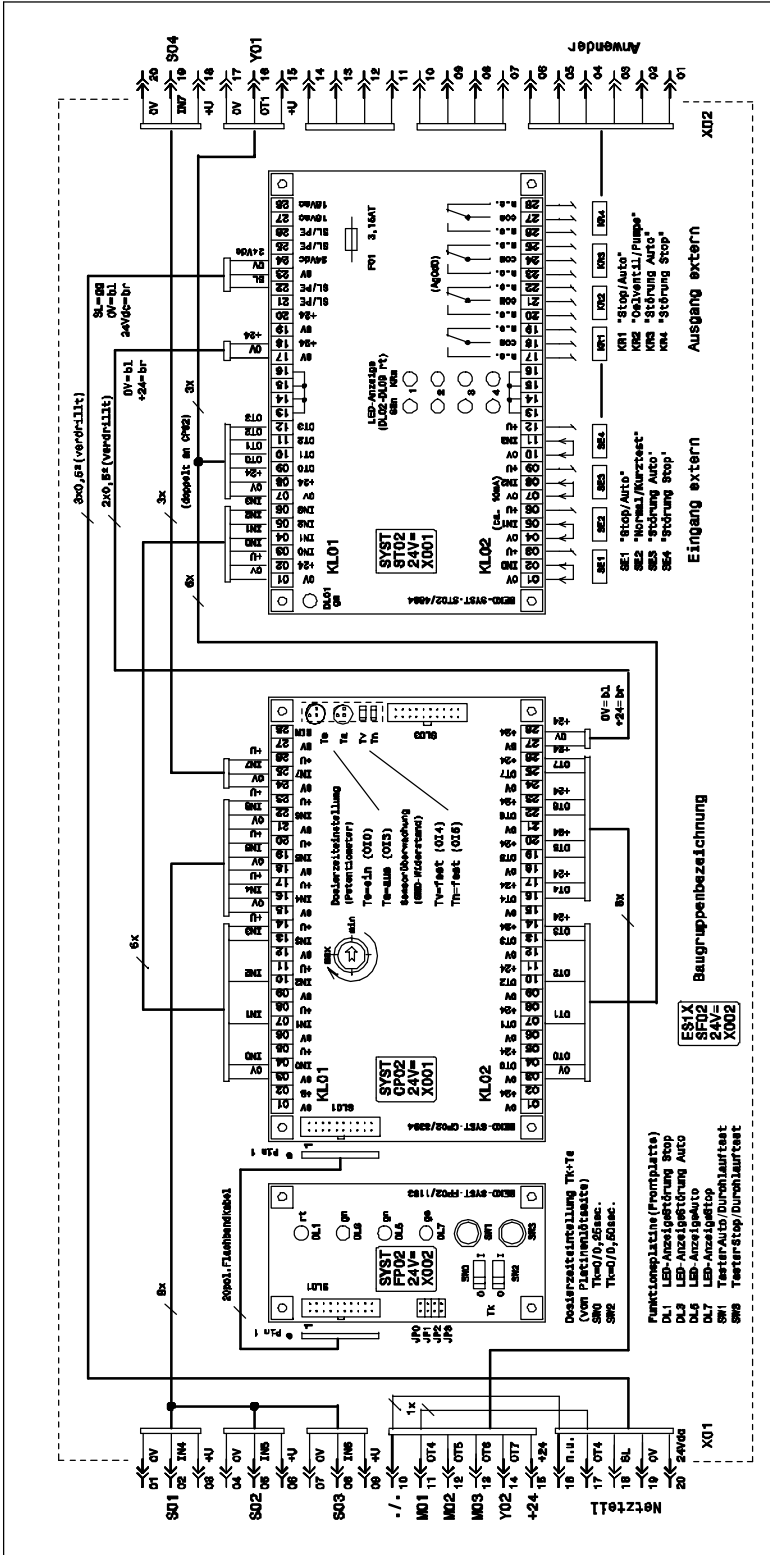

13 Start-up



For safe operation, the plant must only be operated and maintained in accordance with the indications in these operating instructions. In addition, the national and operational statutory provisions and safety regulations, as well as the accident prevention regulations required for the respective case of application, need to be observed during the employment. This applies accordingly when accessories are used.

Non-observance of the installation and operating instructions involves risks for persons, systems, and the environment.

As regards the electrical installation, observe all regulations in force (e.g. VDE 0100 / IEC 60364).

Electrical works must only be carried out by authorized and skilled personnel!



The plant may only be started up when all of the covers and doors were closed.



System performance tests, installation, setting and maintenance measures must only be carried out by authorized and skilled personnel. Only instructed personnel are authorized to carry out settings during the operation.

The dosage setting of the BEKOSPLIT® 14S must, as a matter of principle, only be implemented by authorized and skilled personnel.

Use original BEKO TECHNOLOGIES reaction splitting agents and filters only! (Not included in the scope of delivery).

Check the outflowing cleaned water once a week by means of a reference turbidity!



Warning!

Unauthorized interventions!

Unauthorized interventions may endanger persons and plants and lead to malfunction.

Any modification of the plant or of the function parameters that has not been checked and approved by the manufacturer is potentially dangerous.

Measures:

- System performance tests, installation, setting and maintenance measures must only be carried out by authorized and skilled personnel.
- The dosage setting of the BEKOSPLIT® 14S must, as a matter of principle, only be implemented by authorized and skilled personnel.



WARNING!

Dust explosion through splitting agents!

Dispersed dust particles of the splitting agents can form explosive mixtures which, in the event of ignition, can lead to severe injury and death.



CAUTION!

Filling-in inadmissible liquids!

Inadmissible liquids can lead to health hazards and poisoning.

The BEKOSPLIT® 14S is only intended for condensate from compressed-air compressors.

Other liquids can be aggressive, corrosive, caustic, toxic, or flammable, and contain fire-accelerating constituents. In addition, harmful gases may be released.



CAUTION! **Harmful hydrocarbons!**

Harmful hydrocarbons may exist in the ductwork.

For example:

- Hydrocarbons and other particles which are toxic or dangerous to health in another manner.
- Particles which are contained in high-temperature gases.

Measures:

- As long as the process conditions are not absolutely safe, corresponding precautions, such as the use of a respiratory mask or the purging/detoxification of the ductwork, need to be taken prior to any intervention into the ductwork for maintenance or installation purposes.
- Ensure that the duct system is pressureless before any installation or dismantling works are carried out. In the event that you are not sure in some cases, please check with your local safety representative and/or read the local safety regulations.



CAUTION! **Release of dangerous substances!**

The BEKOSPLIT® 14S must only be operated with condensate from compressed air that is free from aggressive, corrosive, caustic, toxic, flammable and fire-accelerating constituents.

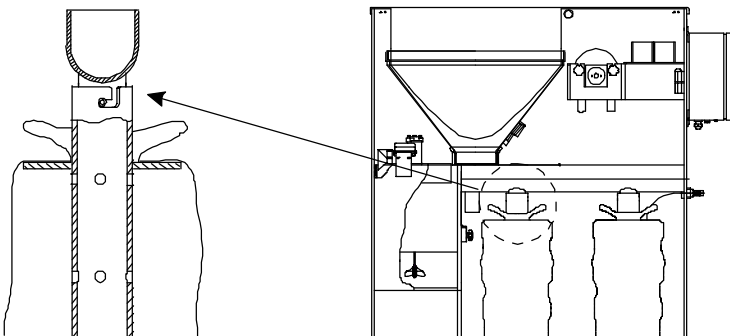

1. Inserting the filter bag

- Open the bayonet lock of the inlet extension.
- Remove the inlet extension.
- Put the filter bag over the inlet extension, attach a tension belt and tighten it.
- Insert the inlet extension with the filter and close the bayonet lock.

The tension belt must have a tight seat. If this is not the case, the filter bag may detach itself and filter cake will emerge.

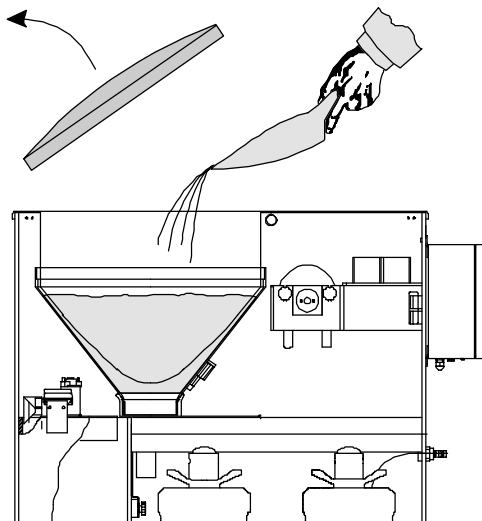

2. Filling-in the reaction release agent

Fill the reaction release agent into the storage reservoir of the dosing device using the enclosed shovel.

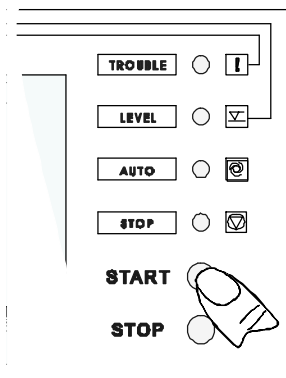

3. Voltage supply

- Connect the voltage supply.
- Switch the main switch at the power supply unit box to "ON".
- Press the START button on the display.
- The BEKOSPLIT emulsion splitting plant is in automatic mode.

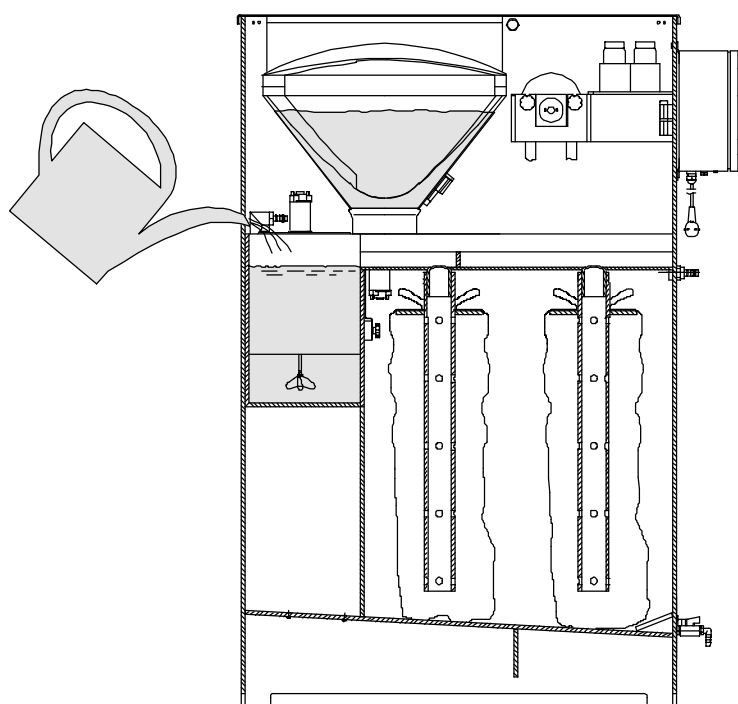

4. Filling the reactor

- Fill the reactor of the BEKOSPLIT splitting plant with tap water until it spills into the discharge channel.
- Stop the water supply.

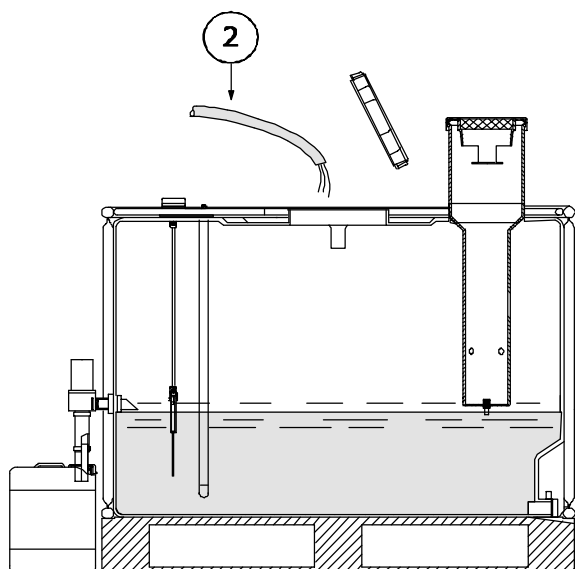

5. Filling the pre-separation container

- Fill the pre-separation container with tap water (2) via the orifice.
- As soon as the liquid level reaches the START sensor, the agitator of the BEKOSPLIT will start.
- Stop the water supply.

The operating level of the pre-separation container is reached (START sensor of the pre-separation container is covered).

- 6. The BEKOSPLIT is serviceable**
Emulsion can now be supplied via the pressure relief chamber of the preseparation container.

14 Operation



Warning! Unauthorized interventions!

Unauthorized interventions may endanger persons and plants and lead to malfunction. Any modification of the plant or of the function parameters that has not been checked and approved by the manufacturer is potentially dangerous.

Measures:

- System performance tests, installation, setting and maintenance measures must only be carried out by authorized and skilled personnel.
- The dosage setting of the BEKOSPLIT® 14S must, as a matter of principle, only be implemented by authorized and skilled personnel.



CAUTION! Filling-in inadmissible liquids!

Inadmissible liquids can lead to health hazards and poisoning. The BEKOSPLIT® 14S is only intended for condensate from compressed-air compressors. Other liquids can be aggressive, corrosive, caustic, toxic, or flammable, and contain fire-accelerating constituents. In addition, harmful gases may be released.

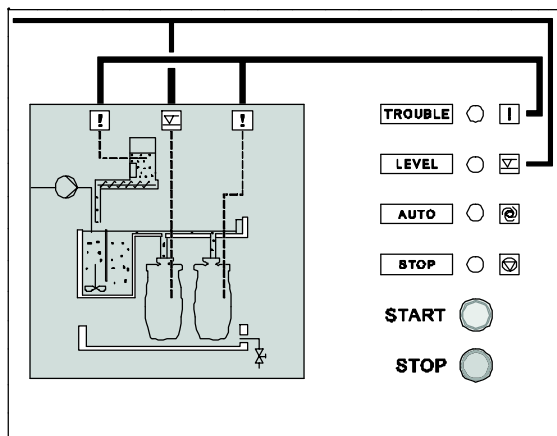

Operation at the display

- Operation of the splitting unit is controlled at the front display.
- Besides the indication LEDs, the display also includes the button functions for the "START" or "STOP" of the splitting unit.

1. START button

- Switching-on the splitting unit

2. STOP button

- Switching-off the splitting unit
- Acknowledgement of trouble indications

3. AUTOMATIC mode

- The splitting unit is serviceable or is in processing operation

4. STOP mode

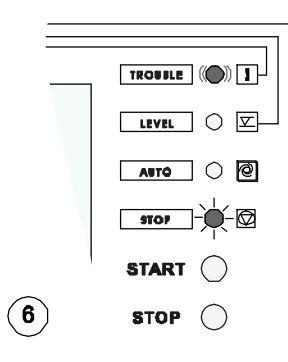
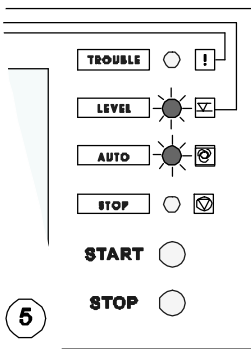
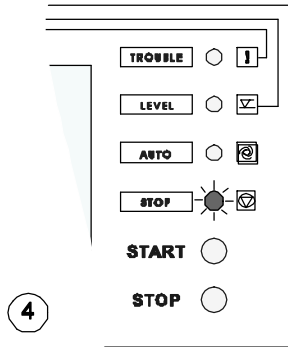
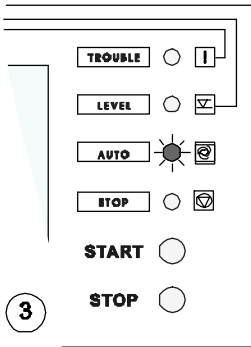
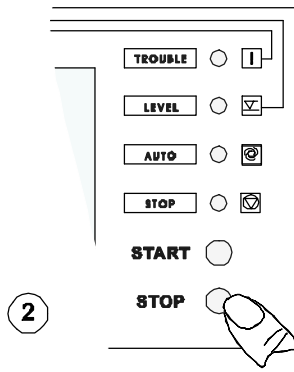
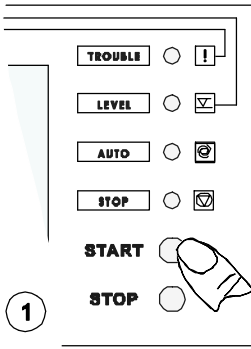

5. Enhanced filling level

- START sensor covered for more than 1,800 s

6. Trouble indication

- Container reaction release agent empty
- Filter bag filled

14.1 Dosage setting

Through the dosage setting, the splitting agent supply of the BEKOSPLIT can be varied over time. The time variation of the splitting agent supply is required in order to achieve a better splitting result at variances in the condensate.

Variances in the condensate can occur

- with an increasing runtime of the used compressor,
- at extreme variations of the temperature and air humidity, which change the oil-water ratio,
- through the energization of further compressors.

Dosage settings are effectuated by means of DIP switches. DIP switches are installed on the inside of the operating unit housing and can vary in shape (see variant 1 and variant 2 in the table).

The BEKOSPLIT® is always delivered with the dosage setting "Setting 1".

Please refer to the following table for the different settings.

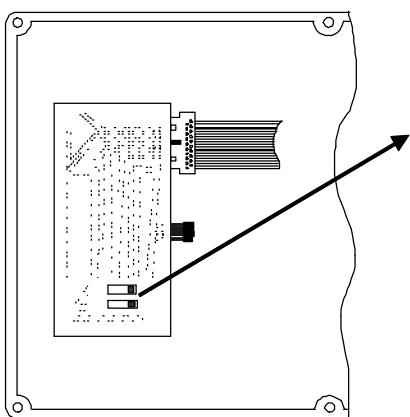

	DIP switch		+
	Variant 1	Variant 2	
Setting 1	ON <input type="checkbox"/> 1 ON <input type="checkbox"/> 1	<input type="checkbox"/> 0 <input type="checkbox"/> 0	Preset
Setting 2	ON <input checked="" type="checkbox"/> 1 ON <input type="checkbox"/> 1	<input type="checkbox"/> 0 <input checked="" type="checkbox"/> 0	0,25 s
Setting 3	ON <input type="checkbox"/> 1 ON <input checked="" type="checkbox"/> 1	<input type="checkbox"/> 0 <input type="checkbox"/> 0	0,50 s
Setting 4	ON <input checked="" type="checkbox"/> 1 ON <input checked="" type="checkbox"/> 1	<input checked="" type="checkbox"/> 0 <input checked="" type="checkbox"/> 0	0,75 s

15 Control and maintenance



For safe operation, the plant must only be operated and maintained in accordance with the indications in these operating instructions. In addition, the national and operational statutory provisions and safety regulations, as well as the accident prevention regulations required for the respective case of application, need to be observed during the employment. This applies accordingly when accessories are used.

Non-observance of the installation and operating instructions involves risks for persons, systems, and the environment.

As regards the electrical installation, observe all regulations in force (e.g. VDE 0100 / IEC 60364).

Electrical works must only be carried out by authorized and skilled personnel!



System performance tests, installation, setting and maintenance measures must only be carried out by authorized and skilled personnel. Only instructed personnel are authorized to carry out settings during the operation.

The dosage setting of the BEKOSPLIT® 14S must, as a matter of principle, only be implemented by authorized and skilled personnel.

Use original BEKO TECHNOLOGIES reaction splitting agents and filters only! (Not included in the scope of delivery).

Check the outflowing cleaned water once a week by means of a reference turbidity!



Warning!

Unauthorized interventions!

Unauthorized interventions may endanger persons and plants and lead to malfunction.

Any modification of the plant or of the function parameters that has not been checked and approved by the manufacturer is potentially dangerous.

Measures:

- System performance tests, installation, setting and maintenance measures must only be carried out by authorized and skilled personnel.
- The dosage setting of the BEKOSPLIT® 14S must, as a matter of principle, only be implemented by authorized and skilled personnel.



WARNING!

Dust explosion through splitting agents!

Dispersed dust particles of the splitting agents can form explosive mixtures which, in the event of ignition, can lead to severe injury and death.



CAUTION!

Filling-in inadmissible liquids!

Inadmissible liquids can lead to health hazards and poisoning.

The BEKOSPLIT® 14S is only intended for condensate from compressed-air compressors. Other liquids can be aggressive, corrosive, caustic, toxic, or flammable, and contain fire-accelerating constituents. In addition, harmful gases may be released.



CAUTION! Harmful hydrocarbons!

Harmful hydrocarbons may exist in the ductwork.

For example:

- Hydrocarbons and other particles which are toxic or dangerous to health in another manner.
- Particles which are contained in high-temperature gases.

Measures:

- As long as the process conditions are not absolutely safe, corresponding precautions, such as the use of a respiratory mask or the purging/detoxification of the ductwork, need to be taken prior to any intervention into the ductwork for maintenance or installation purposes.
- Ensure that the duct system is pressureless before any installation or dismantling works are carried out. In the event that you are not sure in some cases, please check with your local safety representative and/or read the local safety regulations.



CAUTION! Release of dangerous substances!

The BEKOSPLIT® 14S must only be operated with condensate from compressed air that is free from aggressive, corrosive, caustic, toxic, flammable and fire-accelerating constituents.

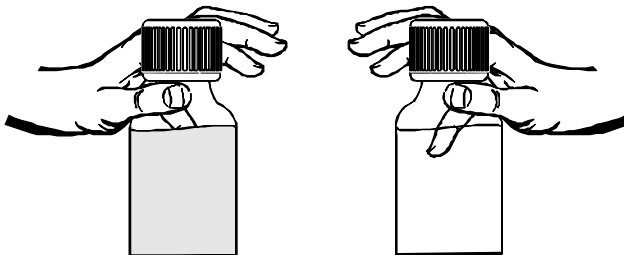

Turbidity check of the wastewater

To check the degree of turbidity, a wastewater sample is taken at the test valve, filled into a test vessel, and is visually compared with the reference turbidity. If the turbidity equals or is stronger than the reference, please contact our service department.

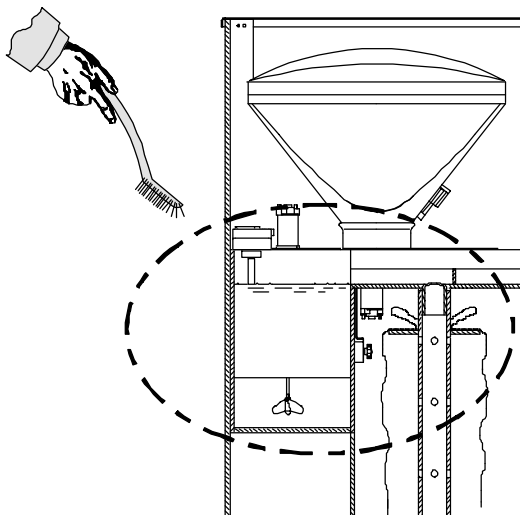

Cleaning measures

Components, such as the reactor wall, the sensor, the agitator shaft and the spillway pipe, which come into contact with reaction release agent flakes, must be checked weekly and cleaned with water. (Do not use rinsing agents and cleaners!)

The cleaning of electrical devices is to be effected using a slightly damp cloth.

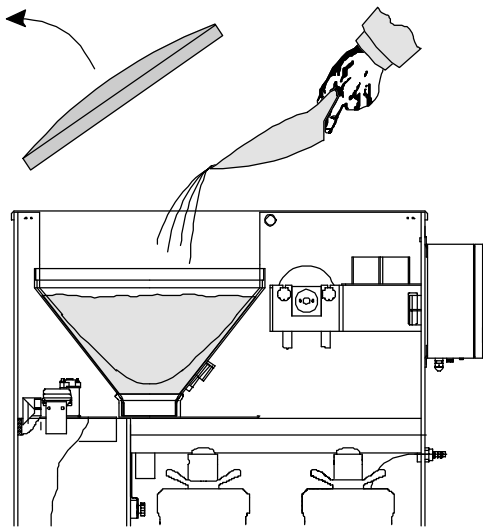

Filling-in the reaction release agent

Fill the reaction release agent into the storage reservoir of the dosing device using the enclosed shovel.

Replacement of the filter bag

Close the channel with a plug.

Detach the tension belt and remove the filter.

Put the new filter bag over the inlet extension, attach the tension belt and then tighten it. The tension belt must have a tight seat. If this is not the case, the filter bag may detach itself and filter cake will emerge.

Remove the plug from the channel.

Dispose of the accumulated filter cake and bag:

European Waste Code: EWC 19 08 14

Note: the wet weight is significantly higher than the dry weight. It is recommended to use a suitable means of transportation.

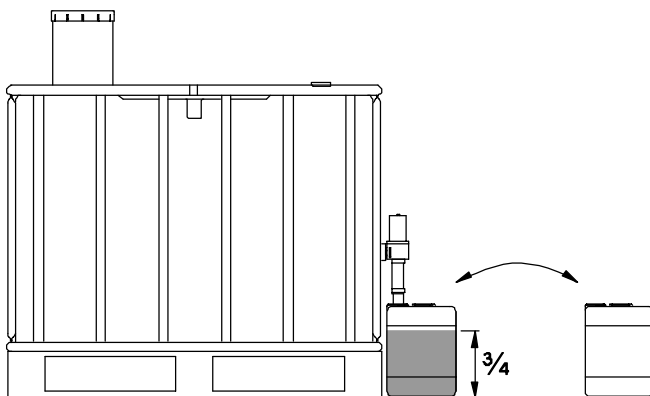
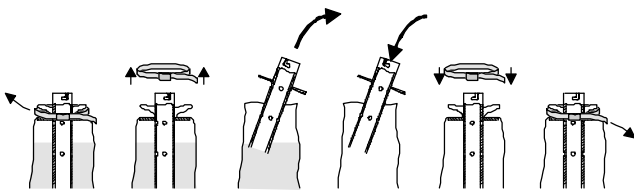

Emptying the oil receiver

Replace the oil receiver by an empty receiver when the receiver is three quarters full.

Dispose of the accumulated oil as used oil:

European waste code:

EWC 13 02 05 (mineral oils)

EWC 13 02 06 (synthetic oils)

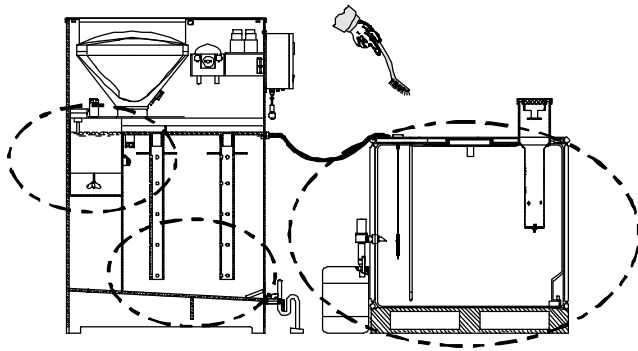

Basic cleaning

Depending on the dirt accumulation from the ductwork of the compressor system, a bi-annual basic cleaning may be necessary.

- Cleaning of the pre-separation container
- Cleaning of the reaction basin
- Cleaning of the clear-water basin

Pump hose replacement

Recommendation: every six months or every 400 hours

16 Fault elimination



For safe operation, the plant must only be operated and maintained in accordance with the indications in these operating instructions. In addition, the national and operational statutory provisions and safety regulations, as well as the accident prevention regulations required for the respective case of application, need to be observed during the employment. This applies accordingly when accessories are used.

Non-observance of the installation and operating instructions involves risks for persons, systems, and the environment.

As regards the electrical installation, observe all regulations in force (e.g. VDE 0100 / IEC 60364).

Electrical works must only be carried out by authorized and skilled personnel!



System performance tests, installation, setting and maintenance measures must only be carried out by authorized and skilled personnel. Only instructed personnel are authorized to carry out settings during the operation.

The dosage setting of the BEKOSPLIT® 14S must, as a matter of principle, only be implemented by authorized and skilled personnel.

Use original BEKO TECHNOLOGIES reaction splitting agents and filters only! (Not included in the scope of delivery).

Check the outflowing cleaned water once a week by means of a reference turbidity!



Warning!

Unauthorized interventions!

Unauthorized interventions may endanger persons and plants and lead to malfunction.

Any modification of the plant or of the function parameters that has not been checked and approved by the manufacturer is potentially dangerous.

Measures:

- System performance tests, installation, setting and maintenance measures must only be carried out by authorized and skilled personnel.
- The dosage setting of the BEKOSPLIT® 14S must, as a matter of principle, only be implemented by authorized and skilled personnel.



CAUTION!

Filling-in inadmissible liquids!

Inadmissible liquids can lead to health hazards and poisoning.

The BEKOSPLIT® 14S is only intended for condensate from compressed-air compressors.

Other liquids can be aggressive, corrosive, caustic, toxic, or flammable, and contain fire-accelerating constituents. In addition, harmful gases may be released.



CAUTION!
Harmful hydrocarbons!

Harmful hydrocarbons may exist in the ductwork.

For example:

- Hydrocarbons and other particles which are toxic or dangerous to health in another manner.
- Particles which are contained in high-temperature gases.

Measures:

- As long as the process conditions are not absolutely safe, corresponding precautions, such as the use of a respiratory mask or the purging/detoxification of the ductwork, need to be taken prior to any intervention into the ductwork for maintenance or installation purposes.
- Ensure that the duct system is pressureless before any installation or dismantling works are carried out. In the event that you are not sure in some cases, please check with your local safety representative and/or read the local safety regulations.



CAUTION!
Release of dangerous substances!

The BEKOSPLIT® 14S must only be operated with condensate from compressed air that is free from aggressive, corrosive, caustic, toxic, flammable and fire-accelerating constituents.



The plant may only be started up when all of the covers and doors were closed.

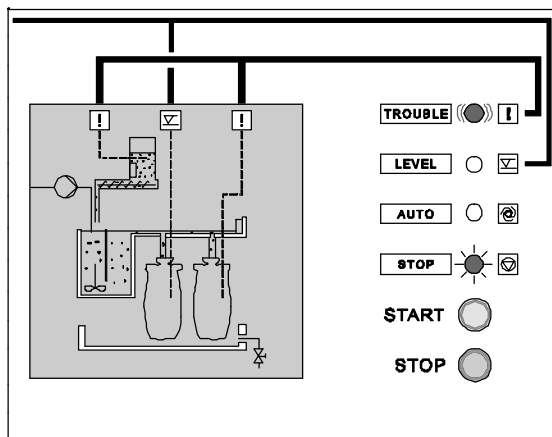

Filter volume exhausted

- Acknowledge the trouble indication with the STOP button on the front display
- Insert the plug into the channel
- Leave the filter bag to drain off and replace it (see the "Replacement of the filter bag" section)
- Remove the plug from the channel
- Press the START button to switch the plant to "AUTOMATIC"

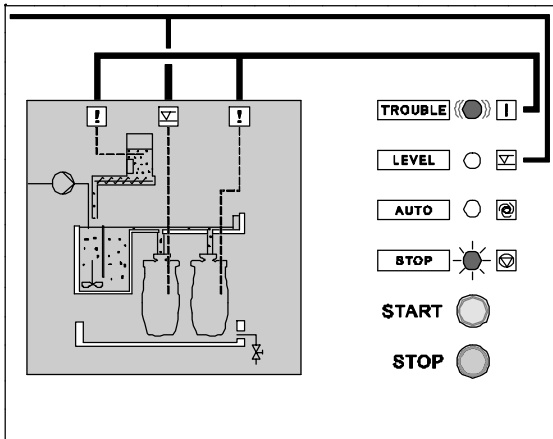

Reaction release agent container empty

- Acknowledge the trouble indication with the STOP button on the front display
- Refill the reaction release agent (see the "Check and maintenance" section)
- Switch the plant to "AUTOMATIC OPERATION" with the START button

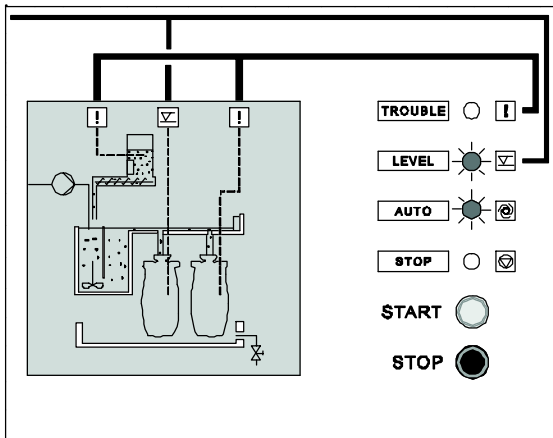

START sensor in the prepreparation container covered for more than 1,800 seconds

- Check the intake, and reduce, if required
- Check the tube pump of the splitting unit for tightness/functioning
- Subsequent to the fault elimination, the message will go out independently

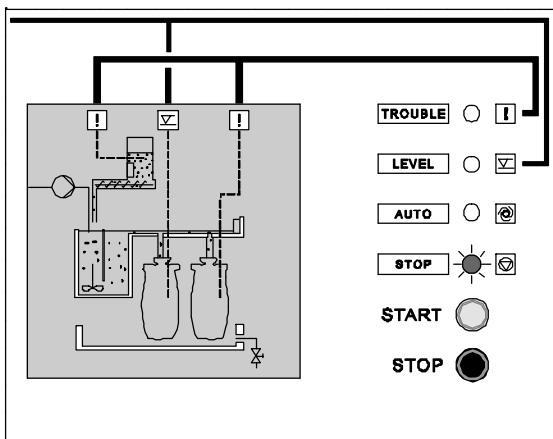

System is in the STOP mode (e.g. subsequent to a power outage or pressing of the STOP button)

- Switch the plant to "AUTOMATIC OPERATION" with the START button.

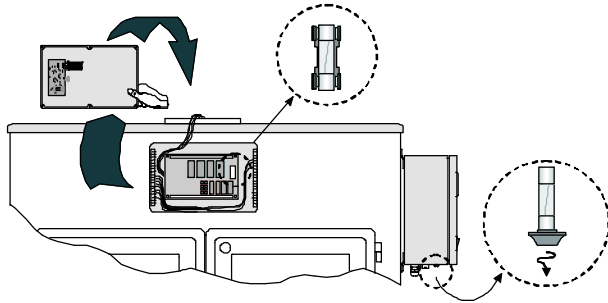

No LED is on, although operating voltage is applied to the power supply unit

- Check the connecting cable between the power supply unit and the front-side plant control
- Check the plug contact of the connecting cable at the plant control
- Check/replace the microfuse of the printed circuit board as follows:
 1. Unscrew the screws of the housing cover.
 2. Remove the housing cover and place it on the BEKOSPLIT® 14S.
 3. Replace the microfuse with a fuse of the same type and nominal capacity (see technical data).
- Check the microfuse in the power supply unit box.

17 Elements and components

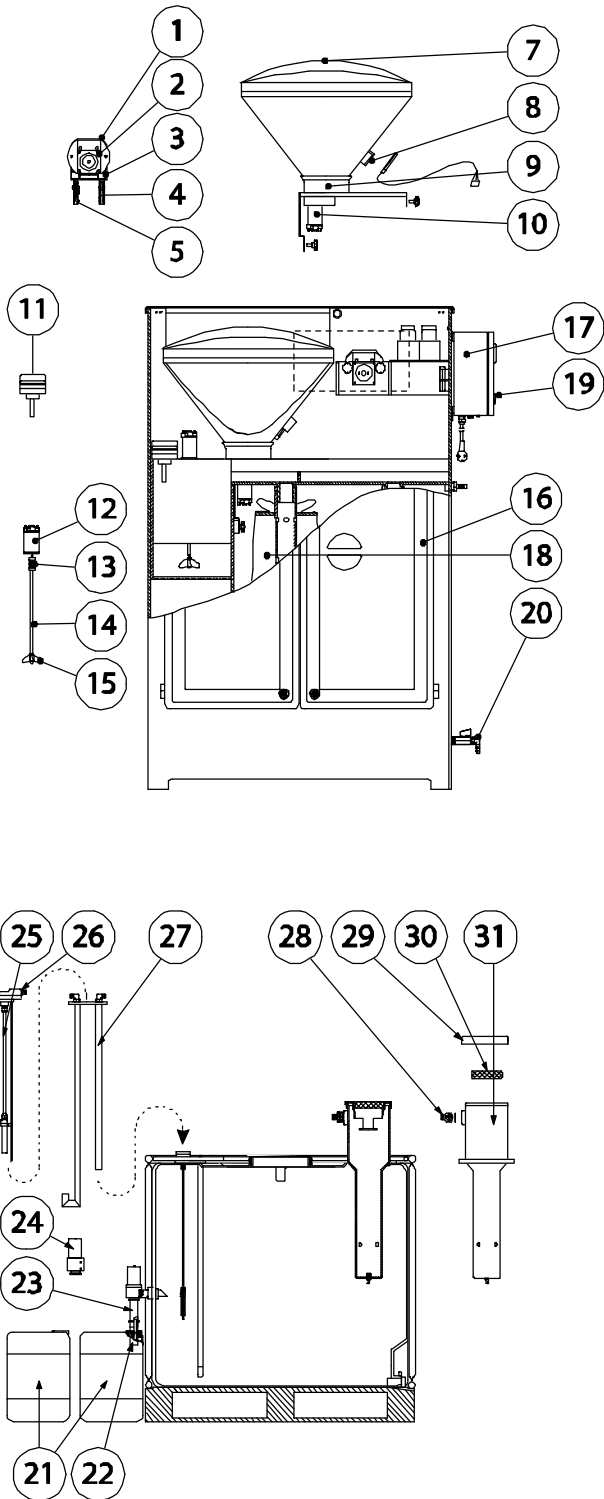

- 1 Emulsion pump head
- 2 Geared motor of the emulsion pump
- 3 Pump hose
- 4 Double nozzle
- 5 Infeed tube
- 6 Carbon brushes (not shown)
- 7 Cover
- 8 Sensor reaction release agent
- 9 Dosing unit
- 10 Geared motor for the dosing unit
- 11 Sensor filter monitoring
- 12 Agitator motor
- 13 Coupling
- 14 Agitator shaft
- 15 Agitator blade
- 16 Door
- 17 Power supply unit box
- 18 Filter bag
- 19 Main switch
- 20 Sampling valve
- 21 Oil receiver
- 22 Inlet connection
- 23 Hose 30 x 4
- 24 Oil drain valve
- 25 START sensor
- 26 Sensor printed circuit board
- 27 Tank console
- 28 Connection adapter
- 29 Cap
- 30 Aerosol filter mat
- 31 Pressure relief chamber

18 Wearing parts

Order no.	Contents	Designation
4003590	3, 4, 5	Set of pump hoses
4014400	6	Set of carbon brushes

19 Spare parts

Order no.	Contents	Designation
4003358	1, 2, 3, 4, 5,	Emulsion pump
4003716	2	Geared motor for the emulsion pump
4008082	7, 9, 10	Dosing unit, complete
4008380	10	Geared motor for the dosing unit
2000391	8	Sensor reaction release agent
2000392	11	Sensor filter monitoring
4004276		Sensor circuit board filter monitoring
2000381	12, 13, 14, 15	Agitator, complete
2000382	12	Agitator motor
2000399	14	Agitator shaft
2002837	7	Cover, complete
2800495		Strap for the filter bag
4007032	17	Power supply unit box
2000011		Operating hour meter
2000547		Control unit
2800887	28, 29, 30, 31	Pressure relief chamber
2800889	25, 26	Filter set for the pressure relief chamber
2001046	24	Connection adapter
2000012	25	START sensor, complete (without a cable)
2000649	26	Sensor circuit board START sensor
2000379	21, 22	Oil receiver set for 600 l tank
2000380	21	Oil receiver 600 l tank
2000599	27	Tank console 600 l tank
2000400	21, 22	Oil receiver set for 1,000 l tank
4003931	21	Oil receiver for 1,000 l tank
2000600	27	Tank console 1,000 l tank
2000101	22	Oil drain valve

Accessories

20 Accessories

Order no.	Designation
2801212	Drying rack for filters
4011184	Collection pan 607 liters*
4011181	Collection pan 1,000 liters*
2002549	Safety container 600 liters*
2002550	Safety container 1,000 liters*

* depending on the size of the used preseparation container

21 Dismantling and disposal of the plant

When dismantling the BEKOSPLIT® 14S, all parts and operating media related must be disposed of separately.

Component material/medium

Filter bag and cake	EWC 19 08 14
Oil receivers	EWC 13 02 05 mineral oils EWC 13 02 06 synthetic oils
Electronics	EWC 20 01 35
Splitting agent	See safety data sheet of the splitting agent
Housing	PP
Door	PS
Cover	PS

Comply with the regulations regarding the disposal of the individual materials and operating media.

22 National technical approval



allgemeine bauaufsichtliche Zulassung
Deutsches Institut für Bautechnik, Berlin

Zulassungs-Nummer Z-83.2-2

The BEKOSPLIT® 14S was approved by the Institut für Bautechnik DIBt (Center of Competence in Civil Engineering), Berlin, Germany, for the treatment of emulsion-containing compressor condensates. An authorization procedure is not required for operation. It will suffice to register the BEKOSPLIT® 14S installation with the regional surveillance authority.

Local regulations regarding the set-up and operation may deviate from the individual points of these instructions; please obtain detailed information from the relevant authority!

23 Declaration of conformity

BEKO TECHNOLOGIES GMBH
41468 Neuss, GERMANY
Tel: +49 2131 988-0
www.beko.de



EG-Konformitätserklärung

Wir erklären hiermit, dass die nachfolgend bezeichneten Produkte den Anforderungen der einschlägigen Richtlinien und technischen Normen entsprechen. Diese Erklärung bezieht sich nur auf die Produkte in dem Zustand, in dem sie von uns in Verkehr gebracht wurden. Nicht vom Hersteller angebrachte Teile und/oder nachträglich vorgenommene Eingriffe bleiben unberücksichtigt.

Produktbezeichnung: Emulsion-Spaltanlage
Modelle: **BEKOSPLIT 11 / 12 / 13 / 14 / 14S / 15 / 16**
Spannungsvarianten: BEKOSPLIT 11: AC100V – AC240V ±10%, 50 – 60Hz
BEKOSPLIT 12 – 16: AC100V, AC110V, AC200V,
AC230V ±10%, 50 – 60Hz

Produktbeschreibung und Funktion: Anlage zum Aufbereiten von emulgiertem
Kompressorenkondensat.

Maschinen-Richtlinie 2006/42/EG
Angewandte Normen: EN 60204-1:2006 + A1:2009 + AC:2010
EN ISO 14121:2007
Name des Dokumentationsbevollmächtigten: Herbert Schlensker

Niederspannungs-Richtlinie 2006/95/EG
Angewandte Normen: EN 61010-1:2001 + AC1:2002
EN 60204-1:2006 + A1:2009 + AC:2010
Anbringungsjahr der CE-Kennzeichnung: BEKOSPLIT 11: 00
BEKOSPLIT 12 / 13 / 14: 95
BEKOSPLIT 14S: 01
BEKOSPLIT 15 / 16: 03

EMV-Richtlinie 2004/108/EG
Angewandte Normen: EN 55014-1:2006
EN 61000-3-2:2006
EN 61000-3-3:1995 + A1:2001 + A2:2005
EN 55014-2:1997 + A1:2001 + A2:2008 Category II

Neuss, 11.10.2013

BEKO TECHNOLOGIES GMBH

i.V. Christian Riedel
Leiter Qualitätsmanagement

BEKO TECHNOLOGIES GMBH
41468 Neuss, GERMANY
Tel.: +49 2131 988 0
www.beko.de



EC Declaration of Conformity

We hereby declare that the products indicated hereafter comply with the stipulations of the relevant directives and technical standards. This declaration only refers to products in the condition in which they have been placed into circulation. Parts which have not been installed by the manufacturer and/or modifications which have been implemented subsequently remain unconsidered.

Product designation: Emulsion splitting plant
Models: BEKOSPLIT 11 / 12 / 13 / 14 / 14S / 15 / 16
Voltage options: BEKOSPLIT 11: AC100V – AC240V $\pm 10\%$, 50 – 60Hz
BEKOSPLIT 12-16: AC110V, AC200V, AC230V $\pm 10\%$,
50 – 60Hz
Product description and function: System for the processing of emulsified compressor condensate.

Machinery Directive 2006/42/EC

Standards applied: EN 60204-1:2006 + A1:2009 + AC:2010
EN ISO 14121:2007
Name of the person authorised to compile the technical documentation: Herbert Schlensker

Low-Voltage Directive 2006/95/EC

Standards applied: EN 61010-1:2001 + AC1:2002
EN 60204-1:2006 + A1:2009 + AC:2010
Year of CE labelling: BEKOSPLIT 11: 00
BEKOSPLIT 12 / 13 / 14: 95
BEKOSPLIT 14S: 01
BEKOSPLIT 15 / 16: 03

EMC Directive 2004/108/EC

Standards applied: EN 55014-1:2006
EN 61000-3-2:2006
EN 61000-3-3:1995 + A1:2001 + A2:2005
EN 55014-2:1997 + A1:2001 + A2:2008 Category II

Neuss, 23 August 2011

BEKO TECHNOLOGIES GMBH

p.p. Christian Riedel
Head of Quality Department

A

Ablauf 19
Accessories 42
Advice, general 7
ANSI Z 535 7
Approval 42
Area of installation 19
AUTOMATIC mode 29

B

Breathing protection 5

C

Cleaning measures 33
Components 40
Connection cooling water outlet 6
Control 32

D

Data 12
Declaration of conformity 43
Dimension drawing 13
Dimensions 13
Dismantling of the plant 42
Disposal 42
Dosiereinstellung 31

E

Electrical installation 20
Elements 40
Emptying the oil receiver 34
Enhanced filling level 30
Exclusion from the scope of application 11
Exclusion of a field of application 11
Eye protection 5

F

Field of application 11
Filling the preseparation container 27
Filling the reactor 27
Filling-in the reaction release agent 26, 34
Function 15

G

General advice 7

I

Inlet 19
Inserting the filter bag 26
Installation 16
Installation and operating instructions 5
Instructions, safety instructions 8

ISO 3864 7

M

Maintenance 32
Mounting 16

N

National technical approval 42
No LED is on 39

O

Operation 29
Operation at the display 29

P

Piktogramme 5
PREVENTION OF DANGEROUS CONDITIONS
11
Process-depending dangers 9
Proper use 11
Protective gloves 6

R

Reaction release agent container empty 38
Replacement of the filter bag 34

S

Safety instructions 8, 9
Safety instructions, general 8
Signal connections 22
Signal words 7
Skilled personnel 8, 20
Spare parts 41
Special safety instructions 9
START button 29
START sensor in the preseparation container 38
Start-up 25
STOP button 29
STOP-Modus 29
Symbole 5
System is in the STOP mode 38

T

Technical data 12
Trouble indication 30
Turbidity check of the wastewater 33
Type plate 4

V

Voltage supply 27

W

Wearing parts 41

Headquarter**Deutschland / Germany**

BEKO TECHNOLOGIES GMBH
Im Taubental 7
D-41468 Neuss
Tel. +49 2131 988 0
beko@beko-technologies.com

中华人民共和国 / China

BEKO TECHNOLOGIES (Shanghai)
Co. Ltd.
Rm.606 Tomson Commercial Building
710 Dongfang Rd.
Pudong Shanghai China
P.C. 200122
Tel. +86 21 508 158 85
info@beko-technologies.cn

France

BEKO TECHNOLOGIES S.à.r.l.
Zone Industrielle
1 rue des Frères Rémy
F- 57200 Sarreguemines
Tél. +33 387 283 800
Info.fr@beko.de

India

BEKO COMPRESSED AIR
TECHNOLOGIES Pvt. Ltd.
Plot No.43/1, CIEEP, Gandhi Nagar,
Balanagar, Hyderabad - 500 037, INDIA
Tel. +91 40 23080275
eric.purushotham@bekoindia.com

Italia / Italy

BEKO TECHNOLOGIES S.r.l
Via Peano 86/88
I - 10040 Leini (TO)
Tel. +39 011 4500 576
info.it@beko-technologies.com

日本 / Japan

BEKO TECHNOLOGIES K.K
KEIHIN THINK 8 Floor
1-1 Minamiatarida-machi
Kawasaki-ku, Kawasaki-shi
JP-210-0855
Tel. +81 44 328 76 01
info@beko-technologies.jp

Benelux

BEKO TECHNOLOGIES B.V.
Veenen 12
NL - 4703 RB Roosendaal
Tel. +31 165 320 300
info@beko.nl

Polska / Poland

BEKO TECHNOLOGIES Sp. z o.o.
ul. Chłapowskiego 47
PL-02-787 Warszawa
Tel +48 22 855 30 95
info.pl@beko-technologies.pl

Scandinavia

www.beko-technologies.com

España / Spain

BEKO Tecnológica España S.L.
Torruella i Urpina 37-42, nave 6
E-08758 Cervello
Tel. +34 93 632 76 68
info.es@beko-technologies.es

South East Asia

BEKO TECHNOLOGIES S.E.Asia
(Thailand) Ltd.
75/323 Romkiao Road
Sansab, Minburi
Bangkok 10510
Thailand
Tel. +66 2-918-2477
info.th@beko-technologies.com

臺灣 / Taiwan

BEKO TECHNOLOGIES Co.,Ltd
16F.-5, No.79, Sec. 1,
Xintai 5th Rd., Xizhi Dist.,
New Taipei City 221,
Taiwan (R.O.C.)
Tel. +886 2 8698 3998
info@beko.com.tw

Česká Republika / Czech Republic

BEKO TECHNOLOGIES s.r.o.
Mlýnská 1392
CZ - 562 01 Usti nad Orlici
Tel. +420 465 52 12 51
info.cz@beko-technologies.cz

United Kingdom

BEKO TECHNOLOGIES LTD.
2 West Court
Buntsford Park Road
Bromsgrove
GB-Worcestershire B60 3DX
Tel. +44 1527 575 778
info.uk@beko.de

USA

BEKO TECHNOLOGIES CORP.
900 Great SW Parkway
US - Atlanta, GA 30336
Tel. +1 404 924-6900
beko@bekousa.com

Translation of the original manual/instructions.

Original instructions are in German

Subject to technical modifications without notice / errors accepted.

bekosplit_14s_manual_en-us_03-089_1502_v00.

Printed in Germany