



WATER CHILLER

Model: **CWE-Q**

Use and Maintenance Manual

Editions Record

Code	Revision	Edition	Changes
7425MUM753	15	11/2020	

Original instructions: **ITALIAN**

EN Translation of the original instructions

Dear Customer,

Thank you for the trust you have placed in us. Please read this manual carefully to obtain the best performance from our product.

In order to avoid incorrect operating conditions and danger for the operators, it is essential that you follow the instructions meticulously as well as the current accident-prevention laws in the country of use.

Every chiller/heat pump in the **CWE-Q** series is tested thoroughly before being packed.

At this stage, checks are made to verify that there are no manufacturing defects and that the machine performs correctly the functions for which it was designed.

This manual must be kept for future reference and is an integral part of the chiller you have purchased.

Due to continuous technical development, we reserve the right to make the necessary modifications without any obligation to give advance notice.

Do not hesitate to contact us if you have any problems or need more information.

The product identification plate, located on the side of the chiller, contains all essential information about the machine.

You will have to give this data to the manufacturer, or reseller, whenever you request information, spare parts, etc., during the warranty period.

Removing or tampering with the identification plate will void the warranty.

Warranty conditions:

The warranty is valid for 12 months from the machine being powered-up and no longer than 14 months from the delivery date. Any part which is recognised as being faulty at source shall be repaired or replaced free of charge. This does not include transport costs, travel, room and board for technicians. The warranty excludes any liability for direct or indirect damage to persons, animals and/or property that are caused by incorrect use or inadequate maintenance and is exclusively limited to manufacturing defects.

Repair under warranty is subject to compliance with the installation, use and maintenance instructions contained in the "User manual and maintenance."

The warranty is considered void if the product is modified or tampered with in any way. When making a warranty request, please supply the information available in the product identification label.

CONTENTS

1	SAFETY RULES.....	1
1.1	Definitions of the symbols used	1
1.2	Warnings	2
1.3	Proper use of the chiller	2
1.4	Instructions for using equipment under pressure conforming to PED Directive 2014/68/EU.....	3
2	OPERATION AND MAIN COMPONENTS.....	4
2.1	Refrigerant circuit	4
2.2	Water circuit	5
2.3	Fans.....	5
2.4	Condensation control	5
2.5	Control of the water temperature	5
2.6	Protecting the integrity of the machine	5
2.7	CWE-Q units: identification of the main components.....	6
2.7.1	Version with P3 TANF LSM BR	6
2.8	Spare parts.....	7
3	INSTALLATION.....	8
3.1	Transport.....	8
3.1.1	Handling the unit with a forklift truck or pallet jack	8
3.1.2	Lifting with belts and tubes.....	8
3.2	Storage.....	8
3.3	Place of installation	9
3.3.1	Installation spaces.....	9
3.4	Water connections.....	10
3.4.1	Recommended water system	10
3.4.2	Use of ethylene glycol as a winter anti-freeze.....	11
3.4.3	Charging the water circuit	11
3.5	Electrical connections	12
3.5.1	Connecting a remote on/off switch and a remote alarm indicator light.....	12
4	PRELIMINARY CHECKS AND START-UP	13
4.1	Preliminary checks and preparation for the first start-up.....	13
4.2	Start-up.....	13
4.2.1	Start-up under critical conditions	14
4.3	Turning off the unit	14
5	ELECTRONIC CONTROLLER.....	15
5.1	Main functions of the electronic controller buttons and meanings of the icons	15
5.2	Switching on/off.....	16
5.3	Controlling water temperature.....	16
5.4	Changing the cooling set point.....	18
5.5	Changing the heating set point.....	18
5.6	Display of inputs and outputs.....	18
5.7	Alarms	18
5.7.1	Displaying and resetting alarms.....	19
5.7.2	Table of alarm codes.....	20
5.7.3	Displaying alarm history	20
5.8	Parameters changing.....	21
5.9	Setting the date and time	21
5.10	Low water temperatures (<32°F//0°C).....	21

6	SAFETY DEVICES	22
6.1	Calibration of the safety devices and type of rearm	22
6.2	Rearming the high-pressure pressure switch	23
7	OPERATING LIMITS	24
7.1	Minimum water flow	26
8	SEPR - SEASONAL ENERGY PERFORMANCE RATIO	27
9	MAINTENANCE, INSPECTIONS AND PERIODIC CHECKS	28
10	TROUBLESHOOTING	29
11	DISMANTLING THE CHILLER	32
12	WATER DIAGRAMS	33
13	REFRIGERANT DIAGRAMS	34
14	DIMENSIONAL DRAWINGS	35

SAFETY RULES

1.1 DEFINITIONS OF THE SYMBOLS USED



Read this use and maintenance manual carefully before performing any repairs on the chiller.



Warnings of a general character; risk of danger or possibility of damaging the machine, pay particular attention to the phrase following this symbol.



Risk of electrical danger; the phrase highlights conditions that could be fatal. Follow the instructions provided meticulously.



Risk of danger; component or system under pressure.



Risk of danger; component or system that can reach high temperatures during operation.



Risk of danger; it is absolutely forbidden to use water to extinguish fires near or on the chiller.



Risk of danger; it is absolutely forbidden to operate the machine with the panel open.



Service that can be performed by the machine's operator, if qualified (1).



Water input connection point.



Water output connection point.



Dispose of each type of material in accordance with the requirements of the country of use.

NOTE

Phrases to be emphasized that do not contain safety rules.



This chiller has been carefully designed and constructed to be environmentally friendly:

- Refrigerants without CFC;
- Expanded foam insulation without CFC;
- Energy-saving techniques;
- Reduced noise;
- The chiller and its packing materials are recyclable.

In order not to hinder our efforts, the user is required to obey the simple ecological warnings indicated by this symbol.

- (1) These are persons with the experience, technical preparation and knowledge of standards and regulations who are qualified to perform the necessary actions and able to recognize and avoid possible dangers while handling, installing, using and maintaining the machine.

1.2 WARNINGS



Only qualified persons may use and maintain electrically-powered equipment. Before commencing maintenance operations ensure no parts of the machine are live and it cannot be re-connected to the electrical power supply.



These chillers contain R410A refrigerant fluids. Service of the refrigerant circuit must be performed by specialized personnel using proper tools.



Any modifications to the machine or related operating parameters not previously verified and authorized by the Manufacturer may be hazardous and will invalidate the guarantee.



Do not use water to extinguish fires near or on the chiller.

1.3 PROPER USE OF THE CHILLER

CWE-Q units are monobloc water chillers with air-condensation.

They are intended for use in industrial process or air-conditioning systems requiring chilled water.

Any other use is considered improper.

The manufacturer is not liable for damage resulting from inappropriate use; in all cases, the user is liable for any resulting hazards.



Proper use requires conforming to the installation conditions and, in particular:

- Power voltage and frequency;
- Pressure, temperature and flow-capacity of the incoming water;
- Surrounding temperature.

The chiller has been tested and completely assembled. The user must only make the connections to other systems, as described in the chapters that follow.

1.4 INSTRUCTIONS FOR USING EQUIPMENT UNDER PRESSURE CONFORMING TO PED DIRECTIVE 2014/68/EU

The proper use of equipment under pressure is an essential prerequisite for ensuring safety. To this end, the user must proceed as follows:

- Use the equipment within the temperature range outlined in the operating limits on the manufacturer's plate;
- Do not solder on the exchangers or refrigerant fluid pipes;
- Do not install the equipment in insufficiently ventilated rooms, areas exposed to sources of heat or near inflammable substances;
- During operation, the equipment must not be subjected to vibrations that could cause fatigue failures;
- Keep the documentation attached to the equipment (user manual, declaration of conformity, etc.) for future reference;
- The maximum operating pressure shown on the manufacturer's plate must not be exceeded. The user is responsible for fitting appropriate safety/control devices.

OPERATION AND MAIN COMPONENTS

2.1 REFRIGERANT CIRCUIT

Operation of the **CWE-Q** chillers is based on a vapour compression cycle implemented within the chiller circuit and made up of the following components - evaporator, compressor, condenser and thermostatic expansion valve.

Evaporator: this is a braise-welded plate that exchanges heat between water and a refrigerant fluid without their coming into contact with each other. It consists of corrugated stainless steel plates braise-welded to each other with copper or of a copper pipe circuit where the refrigerant flows, outside of which (in the iron mantle) the water to be cooled is fluxed. The evaporator is protected against a lack of water by a differential pressure-switch and against the formation of ice by an anti-freeze system managed by the chiller's electronic controller.

Compressor: this compresses the vapours coming from the evaporator and sends them to the condenser at a higher pressure. The **CWE-Q** series has scroll compressors which are characterized by low noise and vibration levels. They are protected by thermal magnetic circuit breakers and a temperature sensor inside the motor windings.

Condenser: heat exchanger with copper pipes and aluminum fins which enables heat exchange between the refrigerant and the air. It condenses the refrigerant gas by transferring condensation heat from the refrigerant gas to the air (which flows to the outside). As a result high pressure liquid refrigerant is produced.

Thermostatic expansion valve: this reduces the pressure of the refrigerant liquid coming from the condenser and sends it to the evaporator. This valve modulates the flow of refrigerant in such a way as to maintain the constancy of the superheating of the gas exiting to the evaporator under its various working conditions and, thus ensures that the flow of gas entering the compressor contains no liquid.

Thanks to these components, the **vapour-compression cycle** works as follows: the refrigerant liquid evaporates in the evaporator, chilling the water; the refrigerant vapours are then aspirated from the compressor, which compresses them and sends them to the condenser under high pressure; here, thanks to a flow of forced air from the fans, the high-pressure refrigerant gas is cooled, making it condensed and undercooled.

The flow of refrigerant liquid then passes through the lamination valve (thermostatic expansion valve), which drastically reduces its pressure: the refrigerant liquid returns to the evaporator at a reduced pressure where it again evaporates, taking heat from the water.

2.2 WATER CIRCUIT

The water circuit mainly consists of: evaporator, water strainer and hydraulic pipes.

The water flows first into the evaporator, where it is chilled, and then it is sent to the system. A differential pressure switch on the evaporator checks that the flow of water is sufficient and stops the compressors if the flow-capacity of the water does not ensure the good functioning of the exchanger.

A fine mesh metal water strainer at the entrance to the evaporator catches any solid residues that could damage the evaporator.

As option, units can be equipped with P3 pump, atmospheric tank, mechanical water level switch and manual regulating bypass valve.

A manometer completes the unit's water circuit.

2.3 FANS

The fans force air through the condenser's fins to remove the heat from the condensation of the refrigerant gas, thus limiting the pressure inside the condenser.

CWE-Q chillers use external-rotor axial fans with thermal protection inside the motor winding.

2.4 CONDENSATION CONTROL

When the ambient air temperature decreases air flow cooling capacity increases considerably, lowering the pressure within the condenser. The fans are switched off (or slowed down in case of CA, CE and CL options) to reduce air flow and prevent the condensation pressure going below the acceptable limits for correct chiller circuit operation.

With CA, CE and CL the fans are actually managed electronically by the condensation pressure, enabling correct machine operation even when the external air temperature is very low (see section **7 Operating limits**).

2.5 CONTROL OF THE WATER TEMPERATURE

The purpose of the chiller is to maintain the temperature of the water produced within a desired interval as the load on the system varies; this is handled by an electronic controller and a temperature probe that turn the compressor on and off appropriately (also see paragraph **5.3 Controlling water temperature**).

2.6 PROTECTING THE INTEGRITY OF THE MACHINE

In addition to controlling the temperature, the electronic controller uses pressure switches, thermostats and timers to prevent and handle situations that could compromise the integrity of the machine (also see Chapter 6 **Safety Devices**).

2.7 CWE-Q UNITS: IDENTIFICATION OF THE MAIN COMPONENTS

2.7.1 Version with P3 TANF LSM BR

Non ferrous atmospheric water circuit with P3 Pump , plastic tank, mechanical water level switch and manual regulating valve.

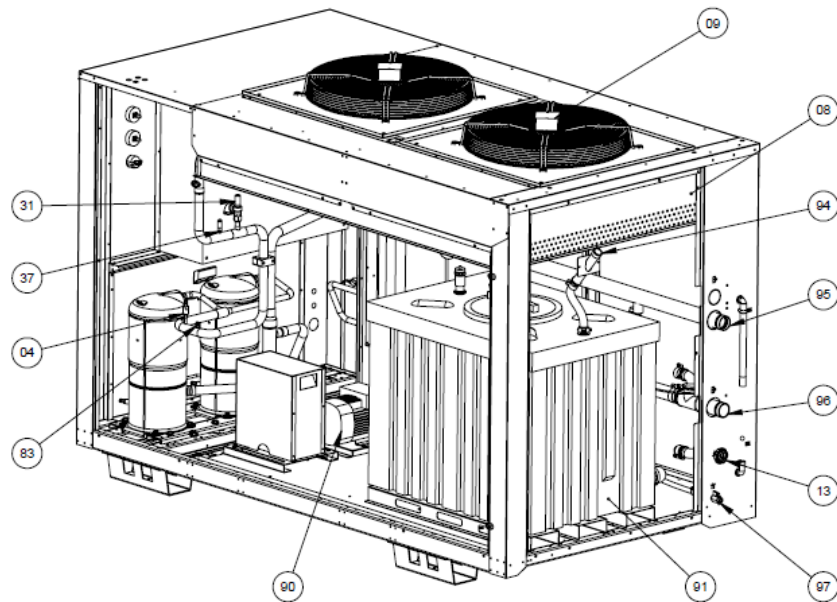
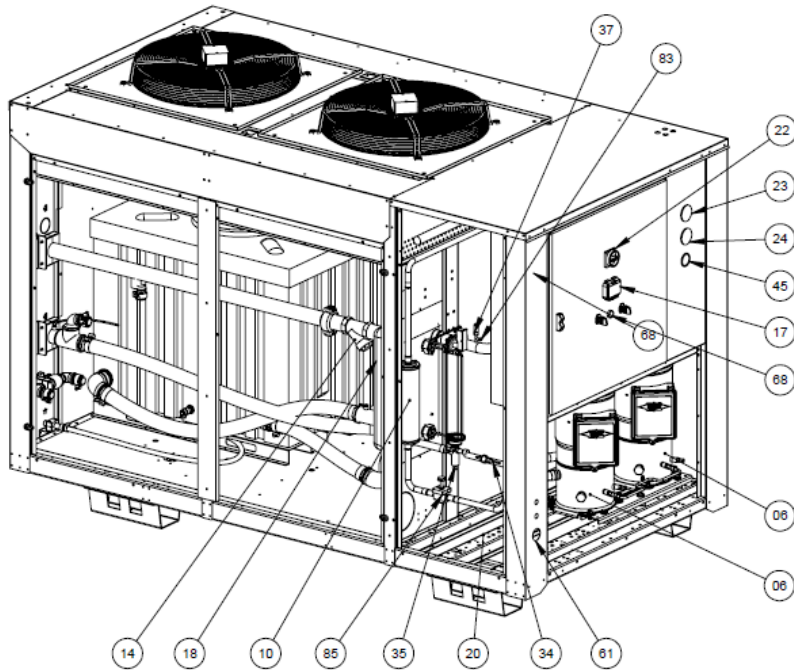

04 High pressure switch
06 Compressor
08 Condenser
09 Fan
10 Filter
13 Gate Valve
14 Water strainer
17 Electronic controller
18 Evaporator

20 Liquid receiver (OPT)
22 Disconnecter switch
23 High pressure manometer
24 Low pressure manometer
31 Safety valve
34 Sight glass
35 Thermostatic valve
37 Pressure transducer
45 Water manometer

61 Power input
68 On/off light
83 Pressure plug
85 Solenoid valve
90 Pump
91 Tank
94 Water filler
95 Water inlet
96 Water outlet
97 Drain

2.8 SPARE PARTS

Spare parts list is printed on a dedicated sticker applied inside the chiller. On this sticker each spare part is identified with its ID Number and related Spare Part Number. Here below the cross reference table between ID Number and exploded drawings Ref. With their description and quantity installed inside chillers.

NOTE To order the suggested spare parts or any other part, it is necessary to quote the data reported on the identification plate.

ID N.	DESCRIPTION	NOTE	PART QUANTITY for CWE-Q S Models			
			041	068	100	140
1	EVAPORATOR GROUP		1	1	1	1
4	HIGH PRESSURE SWITCH		1	1	1	1
6	COMPRESSOR	[A]	1	1	2	2
8	CONDENSER		1	1	1	1
9	FAN		2	2	2	2
10	REFRIGERANT FILTER		1	1	1	1
12	TEMPERATURE PROBE		2	2	2	2
13	GATE VALVE		1	1	1	1
14	WATER FILTER		1	1	1	1
17	COMPLETE ELECTRONIC CONTROLLER		1	1	1	1
18	EVAPORATOR		1	1	1	1
22	DISCONNECTOR SWITCH		1	1	1	1
23	HIGH PRESSURE GAUGE		1	1	1	1
24	LOW PRESSURE GAUGE		1	1	1	1
25	COMPRESSOR CRANKCASE HEATER		1	1	2	2
35	THERMOSTATIC EXPANSION VALVE		1	1	1	1
37	PRESSURE TRANSDUCER		2	2	2	2
89	DIFFERENTIAL PRESSURE SWITCH		1	1	1	1
90	WATER PUMP		1	1	1	1
91	WATER TANK		1	1	1	1
92	WATER LEVEL SENSOR		1	1	1	1

[A]	(ONLY FOR TWO COMPRESSORS MACHINE) The smaller progressive code represents the smallest compressor in tandem configuration.
-----	---

INSTALLATION

3.1 TRANSPORT

The units are provided with protective corner sections in cardboard and transparent film. After checking that the packing is undamaged, position the unit near the installation site and unpack it. The units can be handled using tubes and belts or a forklift truck.



Always keep the chiller vertical: turning it upside down can irreparably damage several parts of the unit.



Handle with care. Violent falls can cause irreparable damage.

3.1.1 Handling the unit with a forklift truck or pallet jack



The centre of the machine is approximately its centre of gravity. In any case, when handling the machine with a forklift truck or pallet jack, always check its stability before lifting.

3.1.2 Lifting with belts and tubes

Base supports that can accommodate bars to raise the units are provided. Use steel tubes with a diameter of 1¼" and at least 0,12 in//3 mm thick and long enough to project at least 9.85÷11,81 in//250÷300 mm from both sides of the machine's profile.



Lock the belts so that they won't slip off during lifting (see figure).

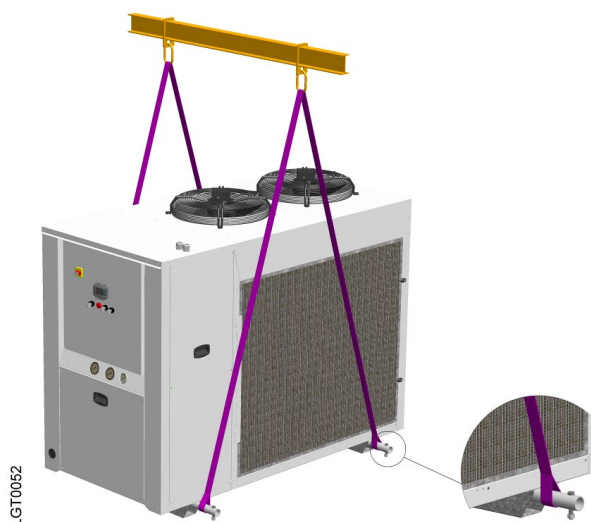

3.2 STORAGE

Protect the machine from bad weather, even if packed. Always keep the chiller vertical, even when in storage. Turning it upside down can irreparably damage several parts of the unit.

If not used, the chiller can be stored packed in an enclosed place, free of dust, with a maximum temperature of 50 °C/122°F and specific humidity of no higher than 90%.



The packing material is recyclable.

Dispose of each type of material in accordance with the requirements in the country of use.

3.3 PLACE OF INSTALLATION

The **CWE-Q** unit can be installed either inside or outside.



Attention! For **CWE-Q** 100÷140 install the 4 rubber mats supplied loose and placed inside the electrical panel, under the feet of the unit.

To determine the best place to install the unit, it is important to consider the following aspects:

- The dimensions and source of the water pipes;
- The location of the electricity;
- The solidity of the support surface;
- Avoid any obstacles to the flow of the fan which could cause the recirculation of air to the condenser;
- Avoid the possible reflection of sound waves: (do not install in narrow or tight spaces);
- Provide access for maintenance or repair (see paragraph **3.3.1 Installation spaces**);
- The air temperatures in the area selected for installation (see Chapter **7 Operating Limits**).



Attention! If the machine is installed outside, it could find itself at a temperature lower than 32°F//0°C, when stopped; the formation of ice could damage the evaporator. If you do not intend to drain the machine during the winter, you must add anti-freeze to the water circuit (see paragraph **3.4.2 Use of ethylene glycol as a winter anti-freeze**).

3.3.1 Installation spaces

To ensure the good functioning of the unit and access for maintenance, you must respect the minimum installation space shown in the figure in this paragraph.

The exit of air from the fans must not be obstructed.

In any case, avoid all situations in which hot air can circulate between the output of the fans and the intake of the machine.

The left or right side of the units can be placed against a wall.

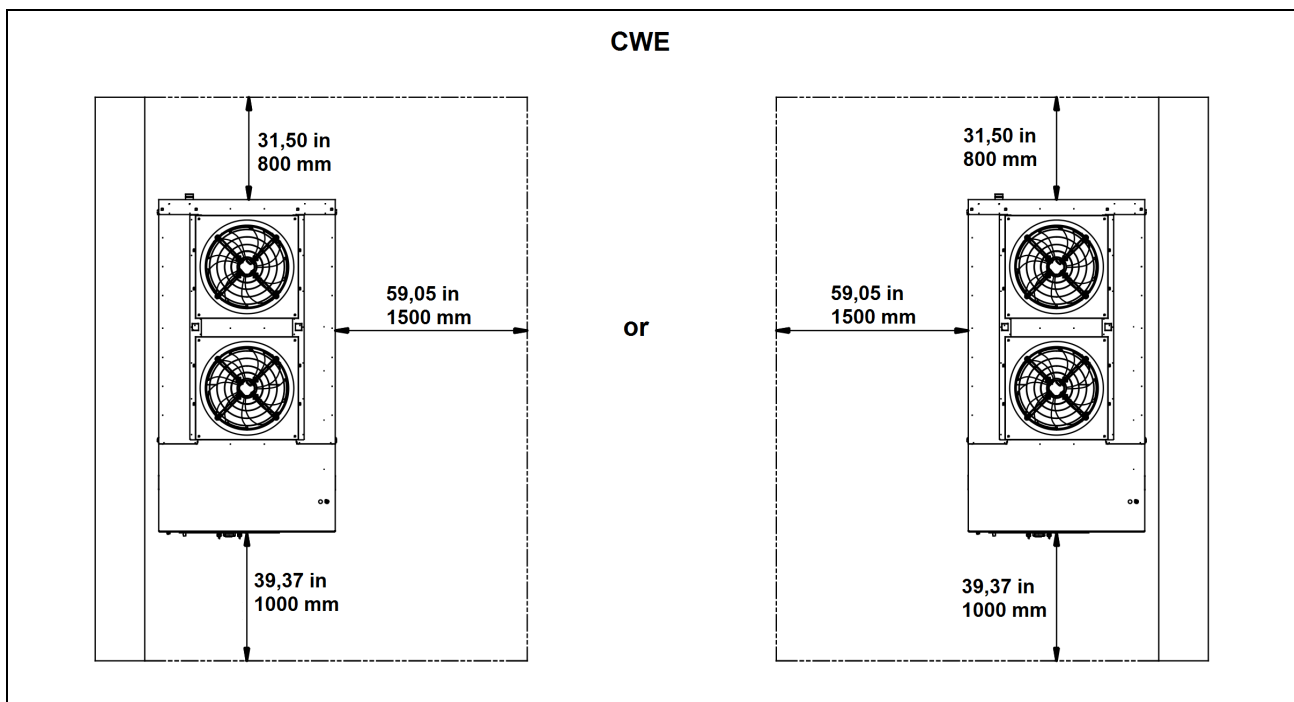

3.4 WATER CONNECTIONS

Connect the machine to the water pipes following the instructions located near its water fittings (see figures).

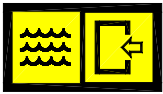

Water input to the machine



Water exit from the machine

LGT0054

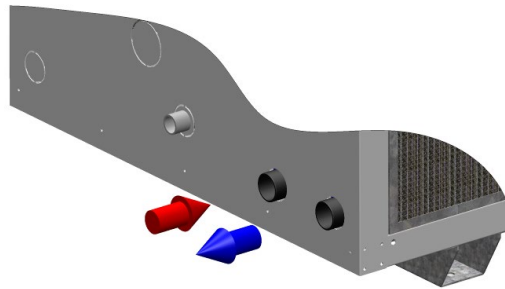

NOTE It is a good rule that the diameters of the arriving and departing pipes be not less than the water fittings.



We recommend an extraordinary cleaning of the mechanical water strainer after the machine has been running for the first week (also see Chapter 9 *Maintenance, inspections and periodic inspections*).

Diameters of the in/out water fittings			
CWE-Q models	041 ÷ 068	100	140
60 Hz version	1½" NPT FF	2" VIC	2" ½ VIC

3.4.1 Recommended water system

The **CWE-Q** units can be provided with pump, tank, water strainer (standard), however it is advisable to also equip the water circuit with:

- A mechanical water strainer and a check valve upstream from the charging tap;
- An air vent at the highest point of the system;
- A drain tap in the lowest point of the system;
- Manometers and thermometers at the machine's water input and output to check its functioning;
- Vibration damping joints on the pipes to avoid the transmission of vibration to the system.



Attention! Never work with an open flame near or inside the unit when making connections to the water system.



Important! If the machine is stopped during the winter, you must empty the system (or just the chiller) to avoid frost damage; any water remaining in the pump must be drained using the screw on the lower part of the pump housing (see figure).

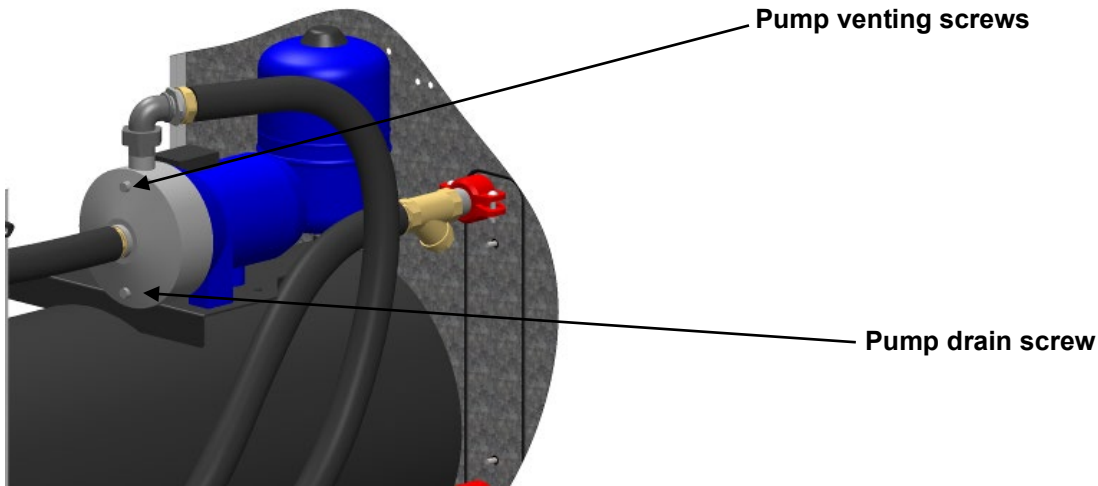

3.4.2 Use of ethylene glycol as a winter anti-freeze

Instead of emptying the system in winter, you can charge the system with a mixture of water and a suitable percentage of ethylene glycol, chosen as a function of the lowest expected temperature of the outside air.

Percentages of ethylene glycol recommended as a function of the expected temperature of the outside air							
Outside air temperature [°C]	0	-5		-10	-12	-15	-20
Outside air temperature [°F]	32	23		14	10.4	5	-4
Percentage of ethylene glycol [%]	10	15		20	25	30	40



Attention! Maximum concentration of ethylene glycol allowed: 40%. For glycol concentrations higher than 40%, contact our company's sales offices to make sure that the mechanical seal and the pump motor are suitable for the type and concentration of fluid loaded in the hydraulic system

3.4.3 Charging the water circuit

- Check that the drain taps are turned off;
- Open all the system's vent valves;
- Turn on the system's shut-off devices;
- Start filling by slowly turning on the system's water-charging tap;
- When water starts coming out of the vent valves, close them and continue charging until the manometer shows at least 1 bar; in case of water tank presence, charge fluid up to maximum level;
- Bleed the pump using the venting screw on the Archimedes screw;
- Check the system level again;
- Check for any leaks by looking at the manometer and inspecting the circuit.

3.5 ELECTRICAL CONNECTIONS



The machine must be connected to the electricity following the electrical diagram and conforming to the current laws and regulations in the place of installation.

- The voltage, frequency and number of phases must conform to the data shown on the machine's identification plate;
- The power supply voltage must not vary by more than $\pm 10\%$ from its nominal value;
- The frequency must not vary by more than $\pm 1\%$ from its nominal value ($\pm 2\%$ for brief periods);
- The imbalance between power phases must be $< 2\%$;
- Upstream from the electrical panel, install a differential switch ($I_{Dn}=0,03A$) (main power switch) and slow-blow fuses with the specifications shown on the electrical diagram;
- Use wires of the section shown on the electrical diagram.



Attention! Never change the internal electrical connections, as the warranty will be immediately voided.



Important! Screw the wires solidly to the terminal strip of the cut-off switch and lock the wire with a cable-gland.



Important! Make the cable entering the machine enters the cable-gland from below: this prevents rain from dripping inside the machine.



Important! The earth connection is mandatory: connect the earth wire to the terminal provided in the electrical panel.

The ground wire must be longer than the other wires so that it will be the last one to be pulled if the device holding the cable loosens.

3.5.1 Connecting a remote on/off switch and a remote alarm indicator light

A remote on/off switch can be connected to terminals in the electrical panel: there are 24V between these two terminals.

An alarm indicator light can be connected to terminals (volt-free) in the electrical panel.



Consult the electrical diagram.

PRELIMINARY CHECKS AND START-UP

4.1 PRELIMINARY CHECKS AND PREPARATION FOR THE FIRST START-UP

Before starting up the unit, it is a good idea to do the following:

- Check that the water shut-off valves are open;
- Check that the pressure shown on the manometer with the pumps stopped is at least 1 bar (for closed water systems); in case of water tank presence, charge fluid up to maximum level;
- Check that the surrounding temperature is in the range for the machine to function (see Chapter 7 **Operating Limits**);
- Check that the cut-off on the electrical panel of the machine is open (0 position);
- Check that the mains voltage matches the voltage on the machine's identification plate with a tolerance of $\pm 10\%$;
- Close the main power supply switch;
- Close the cut-off switch on the machine's electrical panel (I position).

This puts the machine under voltage without starting it up.



Attention! Apply voltage to the machine at least two hours before start-up to give the heating elements in the compressor housing time to heat the oil inside.



Attention! Our company reserves the right of not recognizing the warranty in case of premature breaking down of the compressor, if it is established that this operation is not normally executed by the installer / user of the plant.

The heating elements limit the quantity of refrigerant dissolved in the oil and prevent the oil from migrating when the compressors start.

Before start-up, check that the temperature of the lower part of the compressors is at least 50-59°F [10-15°C] higher than the surrounding temperature.

4.2 START-UP

To proceed to start-up:

1. Press  key for 4 seconds. The led  will flash and turn off, the chiller will switch on;

Electronic controller

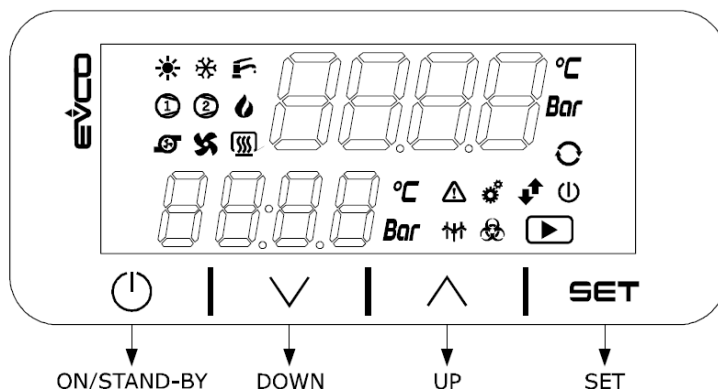

2. Check that the alarm symbol does not light up on the electronic controller;

Attention! At the first start-up there could be an alarm for an incorrect sequence of the R-S-T phases, indicated by the initials **AL27**.

This safety system prevents the compressor from turning in the wrong direction.

Note: the phase sequence relay inside the electrical panel must have both LEDS lit to confirm the correct electromagnetic field.



In this case, turn on the main power supply switch upstream from the machine and reverse the two phases immediately downstream from the main switch.



Attention! Never reverse the wires downstream from the main switch on the electrical panel because doing so risks changing the correct sequence of other devices, such as, for example, the pump and fans.

Repeat the steps from point 1.

3. Check that the pump has started (the pump icon lights up) and check the water pressures upstream and downstream from the machine on the manometers previously installed;
4. Wait for the electronic controller to verify that the water flow is constant through the signal from the differential pressure-switch; if the differential pressure-switch intervenes (alarm code **AL03**), vent the system, check that the shut-off taps and the functioning of the pump are turned on. Reset the alarm following the procedure in paragraph **5.7.1 Displaying and resetting alarms**;
5. Wait for the compressors to start.



4.2.1 Start-up under critical conditions

The consequence of starting up under critical conditions could be the intervention of the high-pressure pressure switch (to rearm the high-pressure pressure switch, see paragraph **6.2 Rearming the high-pressure pressure switch**).

To overcome this problem, you will have to reduce the thermal load on the machine by shutting off some of the uses or, if this is not possible, by reducing the flow of water into the evaporator: partially close the output tap from the chiller and restart the machine.

Operate the chiller under these conditions until the water temperature gradually returns within operating limits; then, you can turn on the tap completely.

4.3 TURNING OFF THE UNIT

For turn off the controller, press  key for 4 seconds The led  will flash and turn on, the chiller will switch off (see paragraph **5.2 Switching on/off**).



Attention! It is important not to turn the unit off using the main power supply switch or the cut-off on the machine's electrical panel because this would not provide for the delayed power-off of the pump regarding the power-off of the compressors, with the risk of damaging the evaporator; in addition, it would prevent the functioning of the heating element in the compressor housing.

ELECTRONIC CONTROLLER

The electronic controller has two 7-segment displays and a series of icons. It manages:

- The functioning of the compressor to ensure that the water produced has a constant temperature;
- The prevention of the high-pressure alarm;
- The prevention of the low pressure alarm.

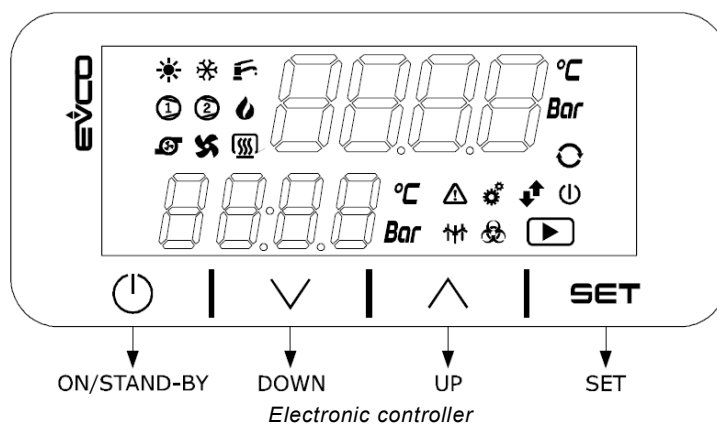

Displays:

















- The state of the unit;
- The state of the compressor;
- The state of the pump;
- The inlet water temperature (upper value);
- The outlet water temperature (lower value);
- All digital and analogue inputs and outputs (navigation between parameters).

Displays the following alarms:



- Water differential pressure switch;
- High-pressure switch;
- Low-pressure transducer;
- Anti-freeze;
- Compressor protection – wrong R-S-T phase sequence;
- Pump's thermal protection;
- Pressure and temperature probe failure.



5.1 MAIN FUNCTIONS OF THE ELECTRONIC CONTROLLER BUTTONS AND MEANINGS OF THE ICONS

Button	Function
⏻	On/off button Exit procedure
SET	Setting setpoint Access the menu
^	Down key
v	Up key

Led/Display	Function
	Indicates the state of compressor: On: compressor ON Off: compressor OFF Flashing: setting setpoint mode or compressor protection
	°Celsius unit
	Unit of measure in Bar
	Indicates the state of the chiller: On: chiller OFF Off: chiller ON
	Alarm active
	Cooling operation (CHILLER mode)
	Heating operation (not used on CWE-Q)
	Domestic hot water function (not used on CWE-Q)
	Boiler function (not used on CWE-Q)
	Report the status of the pump: On: pump active / Off: no pump active / Flashing: pump alarm
	Report fan status: On: fan on / off: no fan active / Flashing: fan alarm.
	Antifreeze heaters (Optional): On: resistors active / Off: no resistance active / Flashing: resistance alarm.
	Hot / cold cycle inversion
	Maintenance LED: On: at least one component is active in manual mode / Flashing: maximum working hours set have been reached by that component.
	Communication LED: Flashing: communication in progress via CANBUS RS 485
	DEFROST mode: Access: DEFROST active / Flashing: dripping phase

5.2 SWITCHING ON/OFF

Connect the device power supply. Press  key for 4 seconds. The led  will flash and turn off, the chiller will switch on.

For turn off the controller, press  key for 4 seconds The led  will flash and turn on, the chiller will switch off.

5.3 CONTROLLING WATER TEMPERATURE

This is the factory setting for the temperature regulation based on evaporator outlet water temperature.

A parameter set the position of the neutral zone of regulation:

- Before or after the setpoint in function of the active mode;
- At the setpoint.

For better understand the regulation mode, two steps must be described:

- Switch on;
- Switch off.

SWITCH-ON:

- The compressor is switched on when the temperature is out of the neutral zone:
 - ✓ COOLING: Working temperature > Set Point + Neutral zone
 - ✓ HEATING: Working temperature < Set Point - Neutral zone
- The compressor is off if the temperature is inside the neutral zone or if:
 - ✓ COOLING: Working temperature < Setpoint
 - ✓ HEATING: T Working temperature > Setpoint

The second compressor is not switched on immediately even if the temperature is still out the neutral zone, but it will be waited the delay sets.

SWITCH-OFF:

- The compressor is switched off when the temperature:
 - ✓ COOLING: Working temperature < Setpoint
 - ✓ HEATING: Working temperature > Setpoint
- The compressor is on if the temperature is inside the neutral zone or if:
 - ✓ COOLING: Working temperature > Setpoint + Neutral zone
 - ✓ HEATING: Working temperature < Setpoint - Neutral zone

The second compressor is not switched off immediately even if the temperature is still out the neutral zone, but it will be waited the delay sets.

Parameters	Description	Factory Setting
SPC1	Cooling setpoint	7°C//44.6°F
SPH1	Heating setpoint	40°C//104°F
PC00	Working temperature probe	1 – outlet water temperature probe
PC14	Neutral zone regulation	5
PC18	Type of neutral zone	0 – separate

The neutral zone regulation is showed in the following picture.

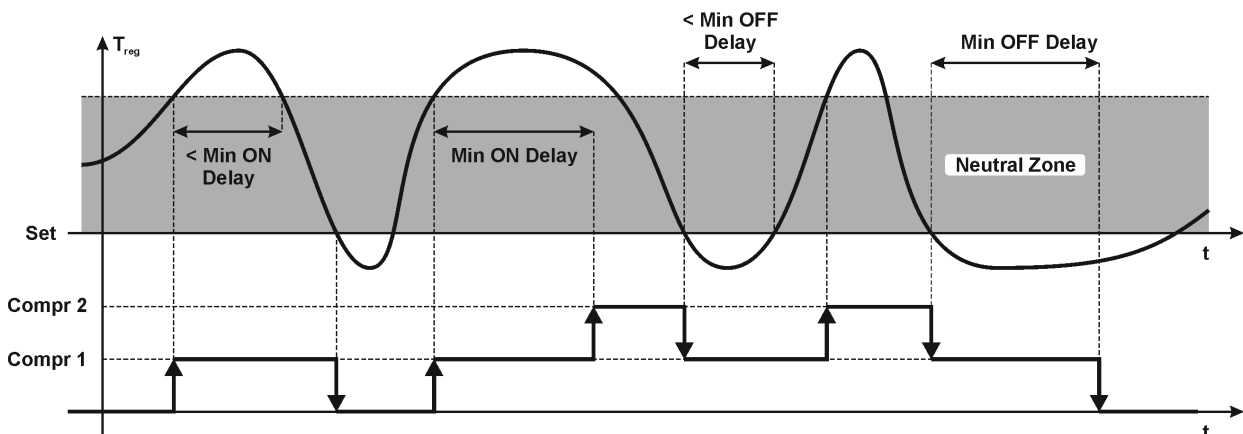

5.4 CHANGING THE COOLING SET POINT







To assign a value lower than to 41 °F//5 °C, the minimum set point value must be changed. To do this contact the manufacturer.







To achieve temperatures that are negative, or near zero, it is necessary to use anti-freeze (ethylene glycol) in percentages that depend on the desired temperature; it is also necessary to change the calibration of the anti-freeze thermostat.

To change the set point of the outgoing water proceed as follows:

- Starting from the main screen press **SET** for 4 seconds and use the  key to reach the **User** menu;
- Press **SET**, and use the  key to reach the **SPC1** parameter;
- Press **SET** to change the value and use  or  keys to set it;
- To confirm press **SET**;
- To exit without saving press .





5.5 CHANGING THE HEATING SET POINT

To change the set point of the outgoing water proceed as follows:

- Starting from the main screen press **SET** for 4 seconds and use the  key to reach the **User** menu;
- Press **SET**, and use the  key to reach the **SPH1** parameter;
- Press **SET** to change the value and use  or  keys to set it;
- To confirm press **SET**;
- To exit without saving press .

5.6 DISPLAY OF INPUTS AND OUTPUTS

It is possible to display the analogue and digital inputs and outputs to check the operation of the machine and its main components.

- Starting from the main screen press **SET** for 4 seconds and use the  key to reach the **Stat** menu;
- Moving with the  and  keys, it is possible to display all the values of the analog and digital inputs and outputs;
- Press  again until you return to the main screen.



Consult the electric diagram.

5.7 ALARMS





An alarm condition is signaled by the Alarm icon .

Some alarms must be rearmed manually while for others, the rearm is automatic or semi-automatic.

- **Manual rearm:** these alarms must be reset, which can only be done when the alarm condition no longer exists; only then can the machine resume operation;
- **Automatic rearm:** the alarm is automatically deactivated as soon as the alarm condition ceases and the machine restarts by itself. However, the signal (Alarm icon) remains on the display until the alarm code is displayed;
- **Semi-automatic rearm:** semi-automatic alarms behave like automatic alarms; but if the same semi-automatic alarm occurs 5 times in 90 minutes, that alarm becomes a manual alarm; therefore to restart the machine, you will have to remove the cause of the alarm and reset it.

5.7.1 Displaying and resetting alarms

The Alarm icon  turns on to indicate an alarm.
To display the code of the alarm that intervened:

- Press the  key;
- Press **SET** at **Alarm** menu;
- Use  or  keys to scroll the list of active alarms;
- Press  again until you return to the main screen.





To reset an alarm, the condition that caused it must no longer exist: for example, if the low-pressure pressure switch has intervened, the alarm can only be reset when the pressure has risen beyond the reset value (see paragraph **Calibration of the safety devices and type of rearm**). Then, after displaying the alarm, wait for normal conditions to be restored, press **SET** again, hold it down for 5 seconds and the alarm will be reset.

5.7.2 Table of alarm codes

Code	Alarm description	Type of rearm
AL01	Water low temperature	Semiautomatic
AL02	Water high temperature	Semiautomatic
AL03	Water differential pressure switch	Manual
AL04	High pressure from pressure switch	Manual
AL06	High pressure from pressure transducer	Automatic
AL07	Low pressure from pressure transducer	Semiautomatic
AL09	Antifreeze	Manual
AL31	Level switch	Manual
AC21	Thermal protection compressor	Manual
AC25	Thermal protection fans	Manual
AC26	Thermal protection pump 1 (optional)	Manual
AC27	Thermal protection pump 2 (optional)	Manual
AL11	High temperature refrigerant discharge	Automatic
AL13	Working limit	Automatic
AL14	Defrost	Automatic
AL27	Phase sequence alarm	Manual
ES01	Inlet water temperature probe	Automatic
ES02	Ambient temperature probe	Automatic
ES03	Outlet water temperature probe	Automatic
ES11	Discharge temperature probe	Automatic
ES12	Suction temperature probe	Automatic
ES14	Temperature probe	Automatic
ES15	Auxiliary probe 1	Automatic
ES16	Auxiliary probe 2	Automatic
AL15	I/O configuration alarm	Automatic

5.7.3 Displaying alarm history







To display the alarm history:

- Press the  key;
- Press **SET** at **Hi St** menu;
- Use **SET** keys to scroll the list of alarms;
- Press  again until you return to the main screen.

5.8 PARAMETERS CHANGING





NOTE The parameters setting can only be changed at a higher level of programming of the electronic control: please request the password by contacting our company.

After contact our company, follow this procedure:

- Starting from the main screen press **SET** for 4 seconds;
- Use the  key to reach the **User** and press **SET** ;
- Use  or  keys to scroll the list;
- Press **SET** to reach the label **PDD1**;
- Then press **SET** and insert using  or  keys the password¹;
- Press **SET** to confirm;
- The complete list of parameter will be available for change;
- Press  to return to the main screen.

5.9 SETTING THE DATE AND TIME

Follow this procedure:

- Starting from the main screen press **SET** for 4 seconds;
- Use the  key to reach the **rtc** menu;
- Press **SET** and using  or  keys insert the date and time;
- Press **SET** to confirm;
- Press  to return to the main screen.

5.10 LOW WATER TEMPERATURES (<32°F//0°C)



If it was not anticipated that the chiller unit offered was to produce water at temperatures close to 0°C//32°F, or below, you should contact our company.



To achieve temperatures that are negative, or near zero, it is necessary to use anti-freeze (ethylene glycol) in percentages that depend on the desired temperature; it is also necessary to change the calibration of safety devices.

NOTE The safety devices setting can only be changed at a higher level of programming of the electronic control: please request the password by contacting our company.



CWE-Q units can operate with water and ethylene glycol mixtures up to a concentration of 40%.



In case of RH and/or RA1 / RA2 / RA3 (HEATING or ANTI-FREEZE RESISTORS) option installed on the machine, check that the Chiller setpoint does not conflict with the one chosen for this option. Contact our Service Assistance to request instructions.

¹ Contact our company.

SAFETY DEVICES

CWE-Q chillers have a series of safety devices that limit the machine's temperature and pressure values to ensure that it operates within the anticipated limits and to avoid dangerous situations.

Here is a list of dangerous situations, including the relative safety device and its location.

Dangerous situation	Safety device	Location
High condensing pressure	High pressure switch	Compressor discharge pipe
High condensing pressure	High pressure prevention system	Electronic controller
Low evaporation pressure	Low pressure transducer	Compressor suction pipe
Low evaporation pressure	Low pressure prevention system	Electronic controller
Low water flow-capacity	Water differential pressure switch	Evaporator heat exchanger
Low water temperature	Anti-freeze thermostat	Water exit from the evaporator heat exchanger
High water pressure	Safety valve (optional)	Water tank (optional)
Frequent compressor start-ups	Anti-circulation timer	Electronic controller
Low water level in the tank	Water level sensor (optional)	Water tank (optional)

When the safety devices reach their setting value, most of them trigger an alarm managed by the electronic controller.



For some safety devices, once the cause of the alarm times out, the machine resumes operation automatically as soon as the reset value is reached. Others must be manually reset to restart the machine (also see paragraph **5.11 Alarms**).

The following paragraph lists the characteristics of each safety device.

6.1 CALIBRATION OF THE SAFETY DEVICES AND TYPE OF REARM

Safety device	Intervention value	Reset value	Type of rearm
High pressure switch	41,5 barg // 602 psi	33 barg // 478 psi	Manual
Low pressure transducer	5,8 barg // 84 psi	6,8 barg // 99 psi	Semiautomatic
High pressure prevention*	40 barg // 580 psi	38 barg // 551 psi	Automatic
Low pressure prevention*	6,8 barg // 99 psi	7,8 barg // 113 psi	Automatic
Water differential pressure switch	85 mbar // 1,24 psi	105 mbar // 1,53 psi	Manual
Anti-freeze thermostat	4°C // 39,2°F	8°C // 46,4°F	Semiautomatic
Water safety valve	6 barg // 87 psi	---	---
Anti-circulation timer**	5 min.	---	---

* Only active on units with more than one compressor: consists in reducing the number of functioning compressors to 1 until the condensation pressure falls below the reset value again.

** This is a function of the electronic controller that prevents the compressor from stopping and starting too frequently: at least 5 minutes must elapse between the compressor's power up and the next.

6.2 REARMING THE HIGH-PRESSURE PRESSURE SWITCH

The intervention of the high-pressure pressure switch is the only case in which, in addition to manually rearming the electronic controller, it is also necessary to reset the pressure switch itself.

The high-pressure pressure switch is located in the compressor compartment on the uninsulated copper pipe that goes from the compressors to the condensing coils; there is a manual-rearm button on top of it. This can only be rearmed when the pressure in the circuit has fallen below the reset value (see table **“Calibration of the safety devices and type of rearm”** in paragraph 7.1).

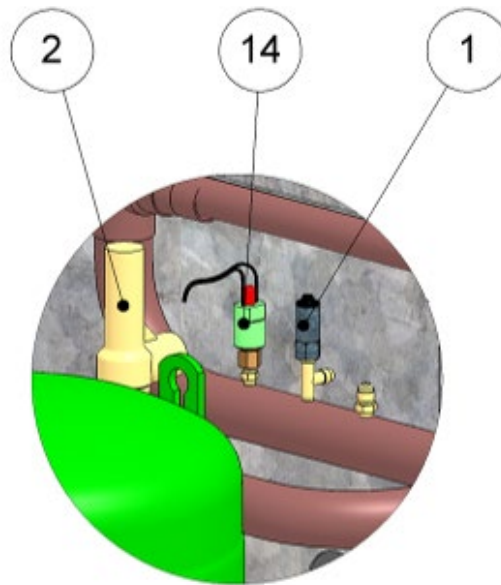

2 – Safety valve
14 – High pressure switch
1 – Pressure transducer

For this reason, when dealing with an intervention of the high-pressure switch, it is necessary to:

- Identify the cause of the rise in pressure (fans not working, condensing coil dirty or obstructed, obstacles to the flow of exiting air, operating temperature outside operating limits, etc. – also see Chapter **10 Troubleshooting**) and remove the cause, if possible;
- Wait until the high-pressure gauge falls below the reset value (see the table **“Calibration of the safety devices and type of rearm”** in paragraph 6.1);
- Rearm the pressure switch by pressing the red button: if you do not hear a click, it is not rearmed.
- Then, rearm the electronic controller: follow the procedure as described in paragraph **5.7.1 Displaying and resetting alarms**.







Caution! The high pressure gauge stops the compressor whereas the condenser fans continue to operate to lower their internal pressure.

OPERATING LIMITS

CWE-Q series units feature broad operating limits in relation to the temperature of the outside air, thanks to the condensation control (also see paragraph 2.4); they are also prepared to produce water at low temperature: in this case, it is necessary to contact our company (see paragraph **5.10 Low water temperatures (<32°F/0°C)**).

The graphs show the continuous operating limits of **CWE-Q** units in relation to the temperature of the water exiting the machine and the temperature of the outside air.

LEGEND

-  Ethylene glycol **mandatory** – contact our company
-  Continuous fan(s) speed control - phase cut type (CA) **mandatory**
-  Continuous fan(s) speed control - electronic fan(s) (CE) **mandatory**
-  Low ambient temperature kit (CL) **mandatory**



Warning! Produced water temperatures less than 5°C//41°F require the use of glycolate mixtures and the setting of suitable electronic controller parameters. Contact the company



Warning! External air temperatures lower than 0°C//32°F can only be achieved with condensation control, continuous fan speed control or low ambient temperature kit. (CA/CE/CL options)



Warning! According to the condensation control chosen and applied on the machinery, verify the real operating limit of the ambient temperature sustainable by the unit.

DIAGRAMS

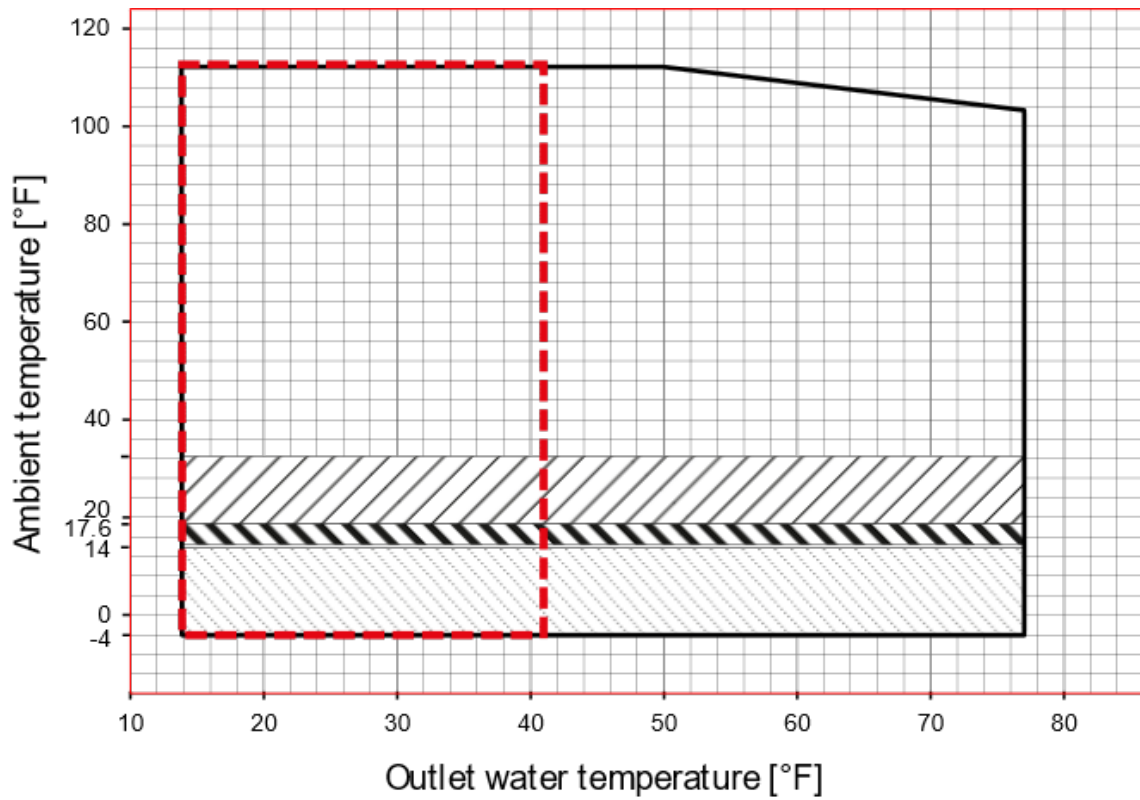
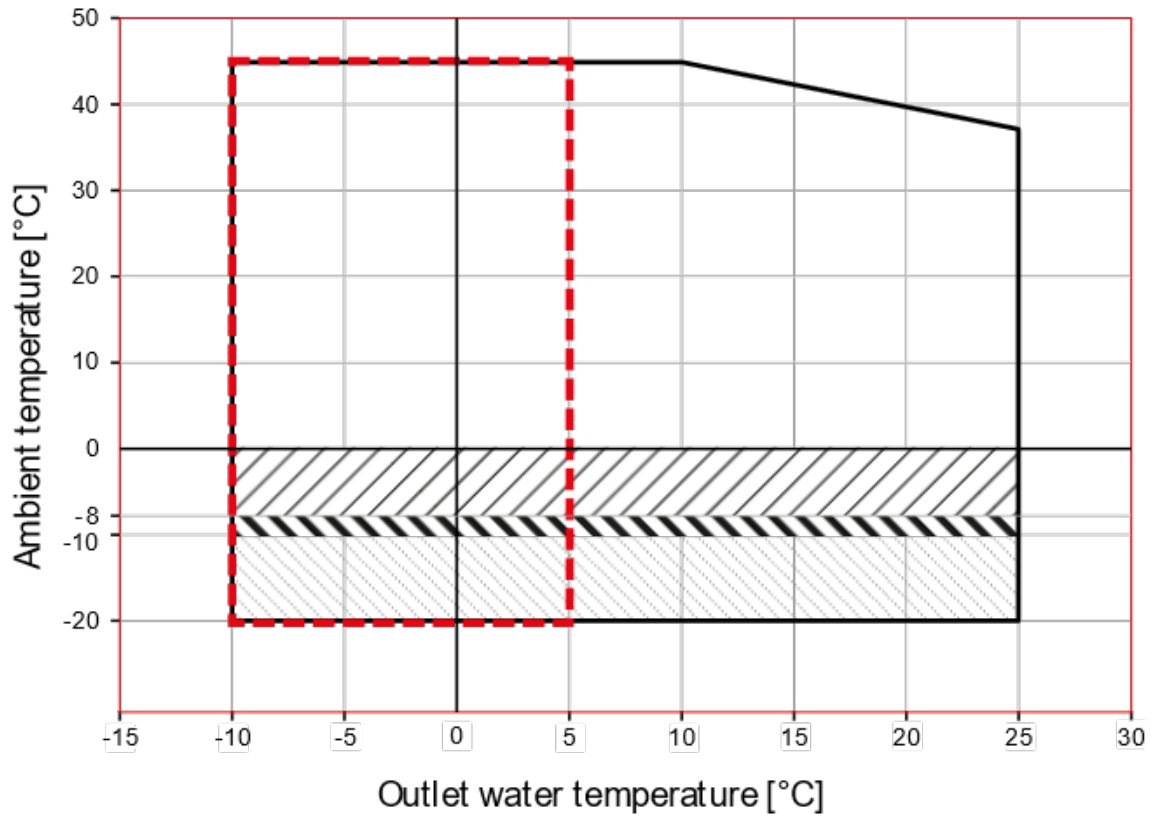

7.1 MINIMUM WATER FLOW



It is recommended to grant a minimum water flow to the chiller in order to avoid serious damages to the evaporator and to the whole machine (see following table).

Model CWE-Q	041	068	100	140
Minimum water flow [gal/min]	11,2	15,9	25,1	35,2
Minimum water flow [m ³ /h]	2,55	3,6	5,7	8



Check that water temperature difference between inlet and outlet of the chiller is less than 14.4°F/8°C; higher values could be the symptom of an insufficient water flow.

SEPR - SEASONAL ENERGY PERFORMANCE RATIO ACCORDING TO COMMISSION REGULATION (EU) 2016/2281

Data reported here below are in accordance with European Regulation (EU) 2016/2281 for eco-design requirements of cooling products and high temperature process chillers.

575V/3Ph/60Hz				
Model CWE-Q	041	068	100	140
SEPR	4,38	4,97	4,89	5,14

MAINTENANCE, INSPECTIONS AND PERIODIC CHECKS



To keep the machine running properly and providing the guaranteed performance required, it is necessary to make some periodic checks.

Operation	Frequency	Execution
Check that the temperature of the water produced is in the required interval	Daily	User
Check for the presence of any alarm signals	Daily	
Check the functioning of the fans	Monthly	
Check the pressure of the water circuit or fluid level into the tank with the pump stopped.	Monthly	
Check that the temperature of the air is compatible with the operating limits of the machine	Monthly	
Clean the air filters	Monthly ⁽¹⁾	
Clean the condensing coil with a jet of compressed air	Yearly ⁽¹⁾	
Clean the water strainer	Monthly ⁽²⁾	Specialised personnel 
Check that the refrigerant liquid sight glass is clear or, at most, with a few bubbles (check with the compressor running)	Every 6 months	
Check that the undercooling and overheating values are, respectively between 3 and 5 K and 5 and 7 K	Every 6 months	
Check for traces of oil on the pipes of the refrigerant circuit (symptom of refrigerant leaks)	Every 6 months	
Check the tightness of the electrical terminals both inside the electrical panel and on the compressors terminals.	Yearly	
Check the contacts of the contactors; if they show signs of deterioration, replace them	Yearly	
Check that the current absorbed by the machine is within the values on the identification plate	Every 6 months	
If the unit will not be used for a long time, drain the water from the plumbings and the machine to avoid the formation of ice during the winter ⁽³⁾	Extraordinary	

(1) It may be necessary to carry this out more frequently in the case of particularly dirty environments.

(2) We recommend an extraordinary cleaning of the water strainer after the machine has been operating for the first week.

(3) It is not necessary to do this if the system has been charged with an anti-freeze solution (water and a suitable percentage of glycol) (see paragraph **3.4.2 Use of ethylene glycol as a winter anti-freeze**).



















Attention! Before carrying out any maintenance on the unit or accessing internal parts, make sure you have cut-off the electricity.









Attention! The upper part of the compressor housing and the discharge pipe are hot. Be especially careful when working near them.

TROUBLESHOOTING

Cause	Alarm signal or symptom	Solution	Execution
1. The unit does not start			
Contacts of the main differential switch open.	Electronic controller off	Close the contacts	User 
Unit's electrical panel cut-off switch open.	Electronic controller off	Close the contacts	User 
Unit is OFF	Electronic controller on with written OFF	Push the button 	User
No consent from the water differential switch	AL03 <i>Differential pressure switch alarm</i>	Check the functioning of the pump, vent the plumbings	User
Compressor timer active	The compressor icon on the display of the electronic controller is flashing	Wait 3 minutes	User
No consent from the service thermostat	Plant water at temperature (see display A)	Apply a thermal load to the machine or lower the set point	User
No consent from the anti-freeze thermostat	AL09 <i>Evaporator ice alarm</i>	Reset a temperature of the water (set point) compatible with the calibration of the anti-freeze thermostat (see table in paragraph 6.2)	User
Service and anti-freeze probe defective	ES03 <i>Alr. Probe Tout evaporator</i>	Check contacts and replace, if necessary	Specialised personnel 
Entering water temperature probe defective	ES01 <i>Alr. Probe Tin evaporator</i>	Check contacts and replace, if necessary	Specialised personnel 
Intervention of the main differential switch	Electronic controller off	Look for current dispersion inside the machine	Specialised personnel 
2. The compressor doesn't start			
Intervention of the thermal protection inside the compressor	The contactor of the compressor is on but the compressor is stopped	Wait for cooling: check that the compressor is working under normal conditions. Check for insufficient refrigerant in the circuit (see point 8).	Specialised personnel 
Contactor of the compressor open	The compressor icon is on but the compressor is stopped	Check the voltage at the coil of the contactor of the compressor and the continuity of the coil itself	Specialised personnel 
Intervention of the phase-sequence relay	AL27 <i>reverse phase sequence</i>	Reverse the two phases upstream from the cut-off switch of the unit's electrical panel (see paragraph 4.2)	Specialised personnel 

Cause	Alarm signal or symptom	Solution	Execution
2. (continue) The compressor doesn't start			
Intervention of the thermal protection inside the compressor OR magnetothermic protection of the compressor open (QC1-QC2)	AC21 <i>Compressors thermal protection</i>	Look for short circuits in the motor windings of the compressor. Check for possible over-absorption of current due to too low voltage; combined with operating conditions near the limits: check the power supply voltage and operating conditions	Specialised personnel 
3. Intervention of the high pressure switch			
Condenser obstructed or insufficient air flow-capacity	AL04 <i>High pressure alarm</i>	Remove dirt from the condenser and any obstacles to the flow of air. Wait for the refrigerant pressure to drop below the reset value (33 bar g), then rearm the high-pressure switch by pressing the button on top of it (see figure in paragraph 6.2)	User
The unit has operated outside its operating limits (such as air or water too hot)	AL04 <i>High pressure alarm</i>	If possible, restore conditions that are compatible with the operating limits. Rearm the pressure switch (paragraph 6.2).	User
Fan not working	AL04 <i>High pressure alarm</i>	See point 6	
Excessive refrigerant charge	High subcooling (greater than 18°F//10K)	Drain excess refrigerant	Specialised personnel 
Presence of incondensable gas or air in the refrigerant circuit	Presence of bubbles on the refrigerant sight glass, also with subcooling values greater than 9°F//5 K	Drain the refrigerant circuit, create vacuum and recharge	Specialised personnel 
Refrigerant filter clogged or thermostatic valve stuck	Pipe downstream from the component covered with frost.	Check and replace.	Specialised personnel 
Water pump blocked or defective (only for heat pump operation)	AL04 <i>High pressure alarm</i>	Unlock or replace the pump	Specialised personnel 
4. Intervention of the water differential pressure switch			
Taps of the machine are turned closed	AL03 <i>Differential pressure switch alarm</i>	Open the taps	User
Water circulation pump blocked or defective	AL03 <i>Differential pressure switch alarm</i>	Unlock or replace the pump	Specialised personnel 
Water pump stopped	AL03 <i>Differential pressure switch alarm</i> Pump icon lit.	Check the voltage at the coil of the contactors of the pump and the continuity of the coil itself	Specialised personnel 
5. Intervention of the low pressure transducer			
Refrigerant filter clogged or thermostatic valve stuck	Pipe downstream from the component covered with frost.	Check and replace	Specialised personnel 
Insufficient refrigerant charge	AL07 <i>Low pressure alarm</i>	See point 8	User
Finned coil dirty or obstructed - air flow too low (only for heat pump operation)		Clean the finned coil and remove anything obstructing air flow	

Cause	Alarm signal or symptom	Solution	Execution
6. Fans don't start			
Very low outside air temperatures and consequent intervention of the condensation control	Fan icon off. Condensation pressure normal	The machine is working anyway	
No voltage output from the fan-speed regulator	Fan icon on and fans stopped	Check the voltage output from the regulator and replace, if necessary	Specialised personnel 
Intervention of the thermal protection inside the fan OR magnetothermic protection of the fan open (QV1-QV2)	AC25 <i>Fans thermal protection</i>	Check that the working conditions of the machine (outside air temperature) are compatible with the operating limits. Wait for the fan motor to cool.	User
Fan fuse blown.	Fan icon on and fans stopped	Look for short circuits in the motor windings of the fans. Check the fan roller bearings.	Specialised personnel 
Electrical connections of the fans loose	Fan icon on and fans stopped	Check and tighten	Specialised personnel
7. The unit is working without ever stopping			
Excessive thermal load.		Reduce the thermal load. Reduce the temperature of the incoming water and/or the flow-capacity of the water by closing the exit tap of the unit a little.	User
No refrigerant.		See point 8	
8. Compressor suction pipe covered with frost			
No refrigerant.	High superheating, low subcooling and high discharge temperature of the compressor. Traces of oil on the refrigerant circuit.	Check the refrigerant circuit with a leak detector. Repair any ruptures and recharge the circuit.	Specialised personnel 
9. The pump doesn't start			
Excessive water flow-capacity. Magnetothermic protection of the pump open (QP1-QP2)	AP26, AP27 <i>Pump 1, 2 thermal protection alarm</i>	Reduce the flow-capacity of the water by closing the output tap of the pump a little bit. Rearm the thermomagnetic protection of pump QP1.	User 
Short circuit or overcurrent.	AP26, AP27 <i>Pump 1, 2 thermal protection alarm</i>	Look for a short circuit in the winding of the pump motor. Check for possible over-absorption of current due to too low voltage; check the power supply voltage.	Specialised personnel 
10. The unit starts and stops alternatively; The outlet water temperature varies greatly			
Low water flow		Verify the water flow. Open the water shut-off valves of the plant. If it is possible, reduce the pressure drop of the water circuit. If it is possible, add a pump with proper available pressure.	Specialised personnel 

DISMANTLING THE CHILLER



If the chiller is being dismantled, you must separate it into parts of homogeneous material.

The following table lists the main materials of the various components of the machine.

Part	Material
Refrigerant fluid	R410A, Oil
Panelling and supports	Carbon steel, epoxy paint
Chiller compressor	Steel, Copper, Aluminium, Oil
Heat-exchanger (evaporator)	Steel, Copper
Condenser	Aluminium, Carbon Steel
Pipe	Copper
Fan	Aluminium, Copper, Steel
Valve	Steel, Bronze
Insulation	Synthetic rubber without CFC, EPS, Polyurethane
Electrical wires	Copper, PVC
Electrical parts	PVC, Copper, Bronze

We recommend that you follow current safety norms for the disposal of each single material. The refrigerant contains particles of lubrication oil from the chiller compressor.



Dispose of refrigerant properly. Remove it from the chiller with suitable tools and deliver it to authorised collection centres that will treat it and make it reusable.

WATER DIAGRAMS

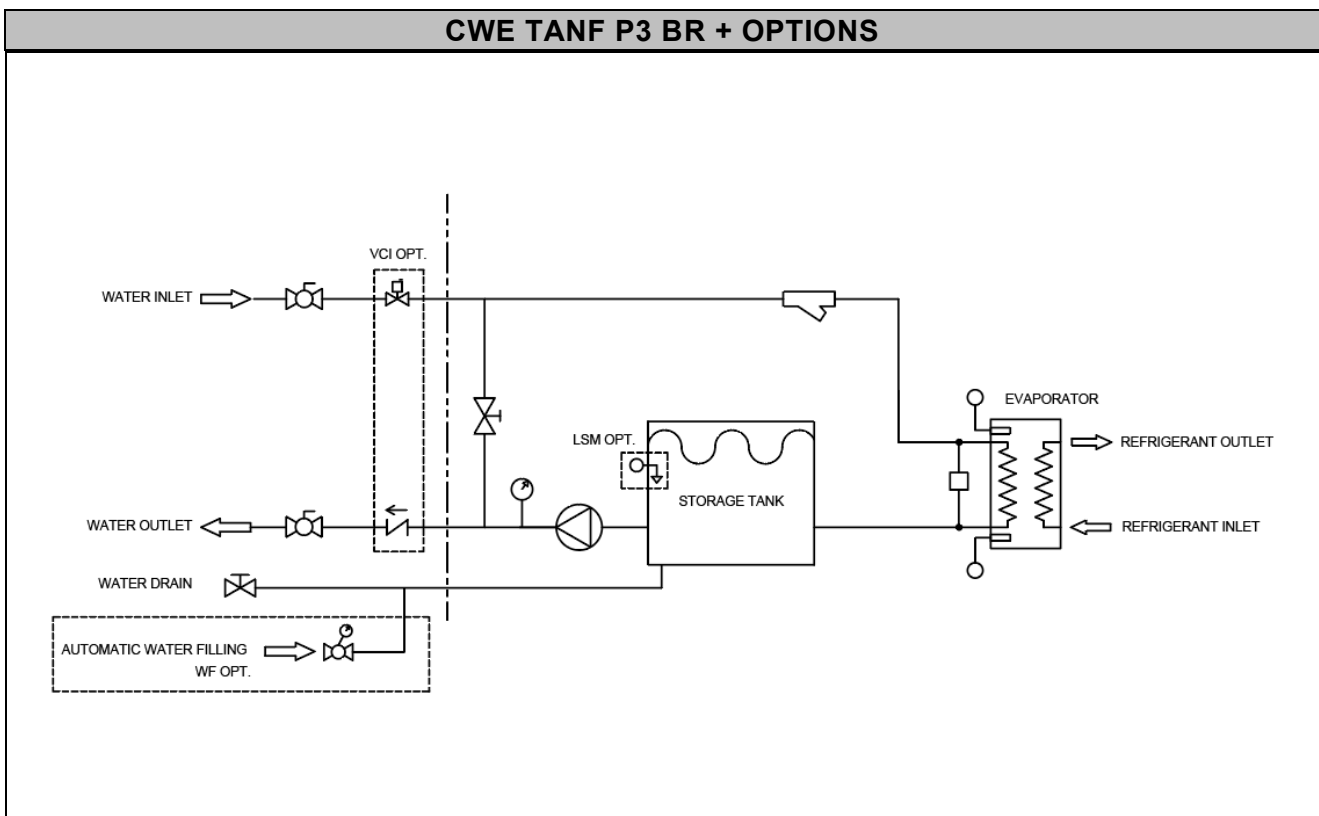
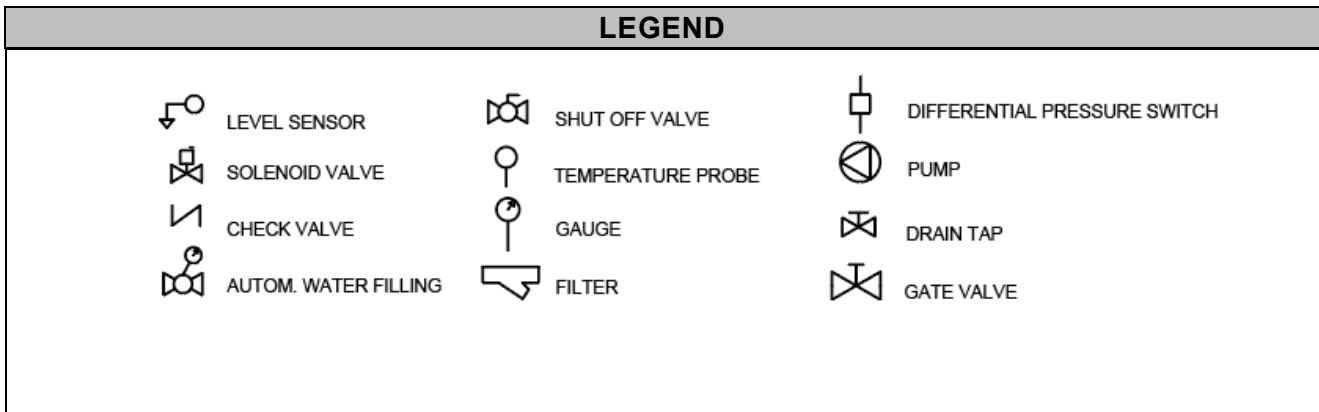

REFRIGERANT DIAGRAMS

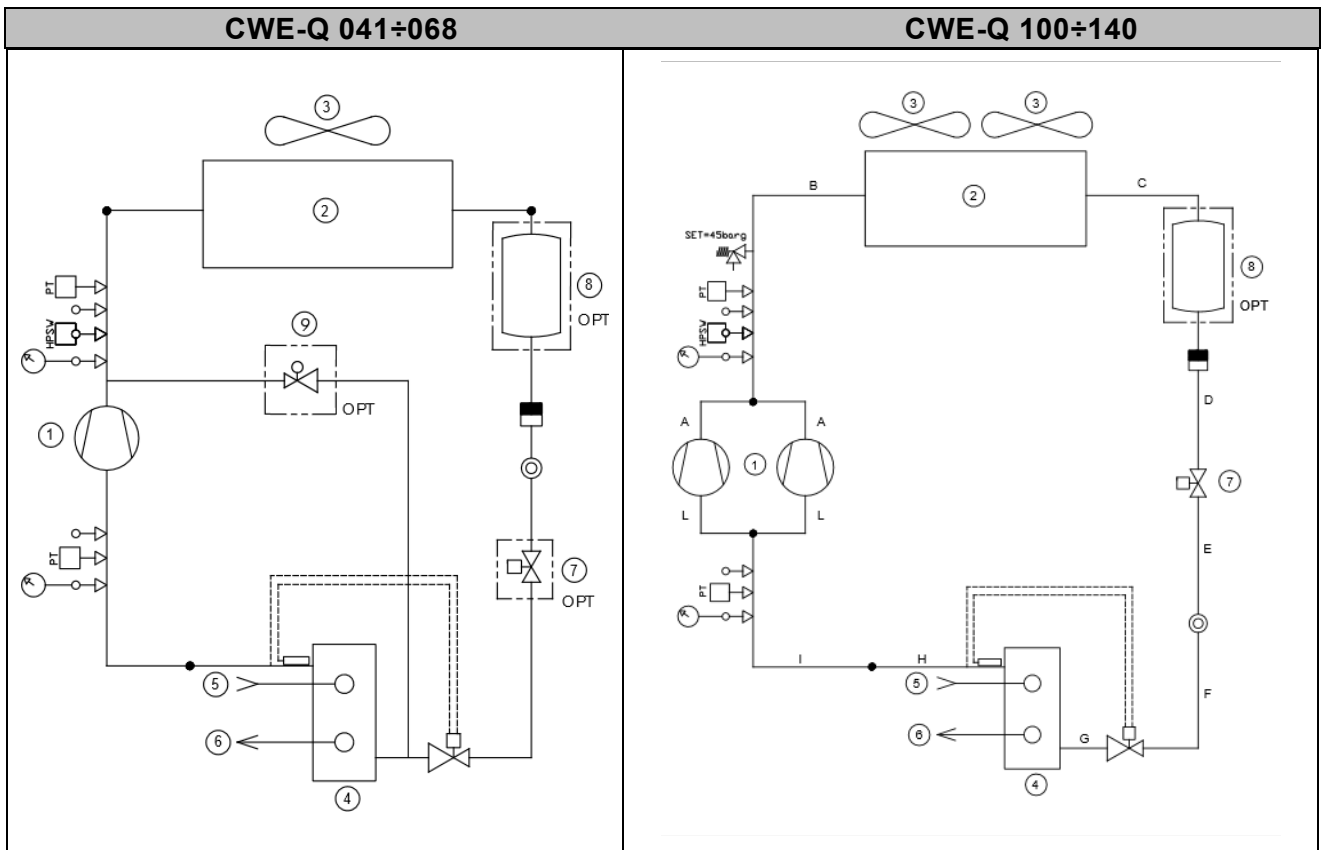
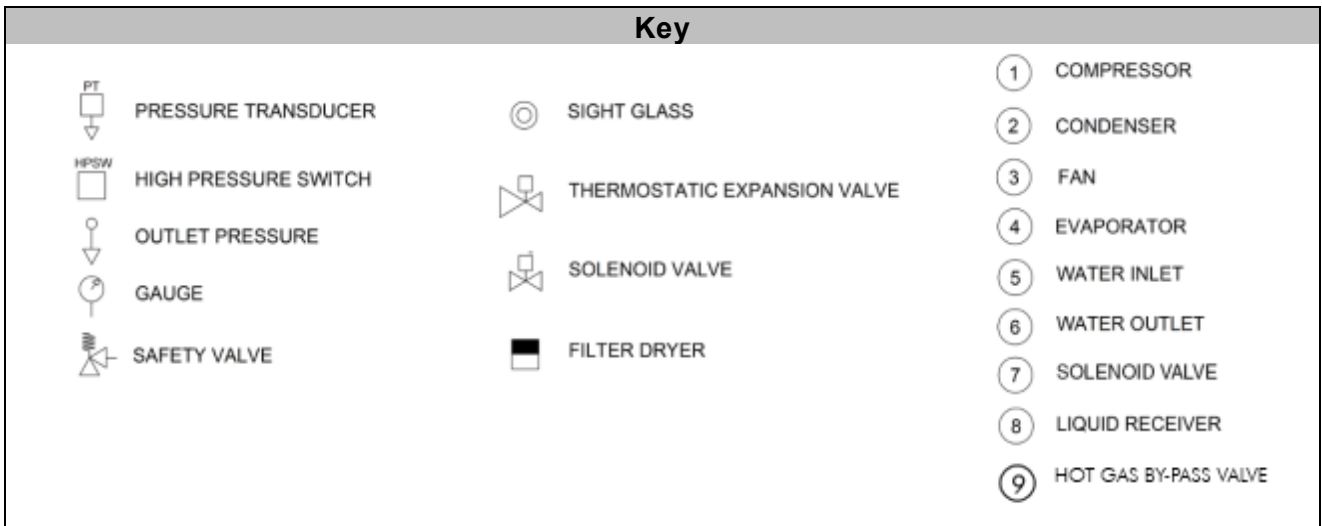

DIMENSIONAL DRAWINGS

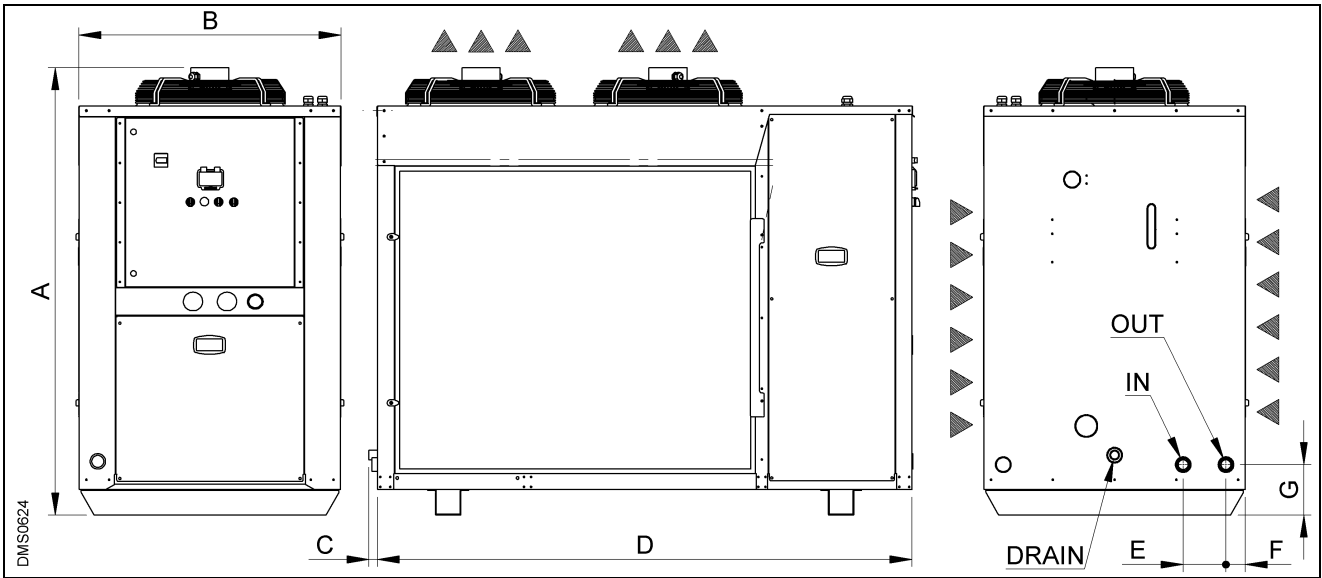

Models CWE-Q	A [mm]	B [mm]	C [mm]	D [mm]	E [mm]	F [mm]	G [mm]	IN	OUT	DRAIN
041-068	1600	922	19	1890	151	68	200	1"1/2 FM	1"1/2 FM	1" FM
Models CWE-Q	A [in]	B [in]	C [in]	D [in]	E [in]	F [in]	G [in]	IN	OUT	DRAIN
041-068	63,57	36,31	0,73	74,43	5,94	2,69	7,83	1"1/2 FM	1"1/2 FM	1" FM

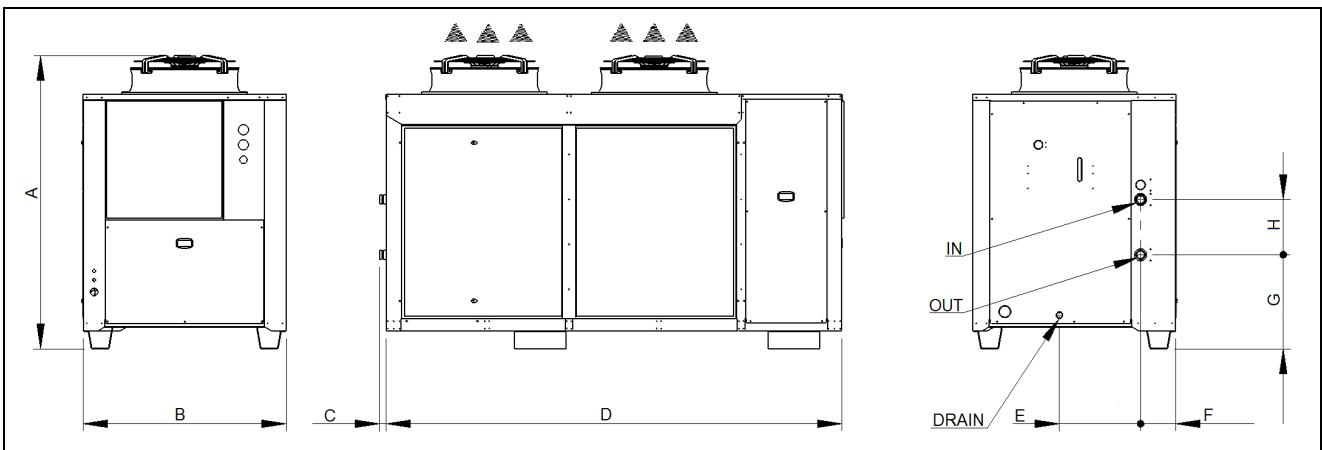

Models CWE-Q	A [mm]	B [mm]	C [mm]	D [mm]	E [mm]	F [mm]	G [mm]	H [mm]	IN	OUT	DRAIN
100	1955	1376	45	2588	550	238	628	466	2" VIC	2" VIC	1" FM
140	1956	1376	45	3088	550	238	628	369	2" VIC	2" VIC	1" FM
Models CWE-Q	A [in]	B [in]	C [in]	D [in]	E [in]	F [in]	G [in]	H [in]	IN	OUT	DRAIN
100	76,98	54,17	1,85	101,89	21,65	9,37	24,73	14,53	2" VIC	2" VIC	1" FM
140	76,97	54,17	2,01	121,57	21,65	9,37	24,73	14,53	2"1/2 VIC	2"1/2 VIC	1" FM



CAG PURIFICATION INC. Unit 2, 3770B Laird Road, Mississauga ON. L5L 0A7
Toll 1-800-951-0777 Fax 905-820-3490 www.cagcooling.com email: chillers@cagcooling.com
