

This drawing cannot be reproduced, copied or given to
third parties without FRIULAIR's written authorization

Questo disegno non può essere copiato, riprodotto né ceduto
a terzi senza autorizzazione scritta della FRIULAIR S.r.l.

Titolo - Title

SCHEMA ELETTRICO CWU010÷020
ELECTRICAL DIAGRAM CWU010÷020

Disegno n° - Drawing nr.

FRCWU90CWU020R0000

Revisione - Revision

00

FRIULAIR
Dryers

FRIULAIR S.r.l. - 33050 CERVIGNANO DEL FRIULI (UD) - ITALY - Via Cisis, 36

This drawing cannot be reproduced, copied or given to third parties without FRIULAIR's written authorization

Questo disegno non può essere copiato, riprodotto né ceduto a terzi senza autorizzazione scritta della FRIULAIR S.r.l.

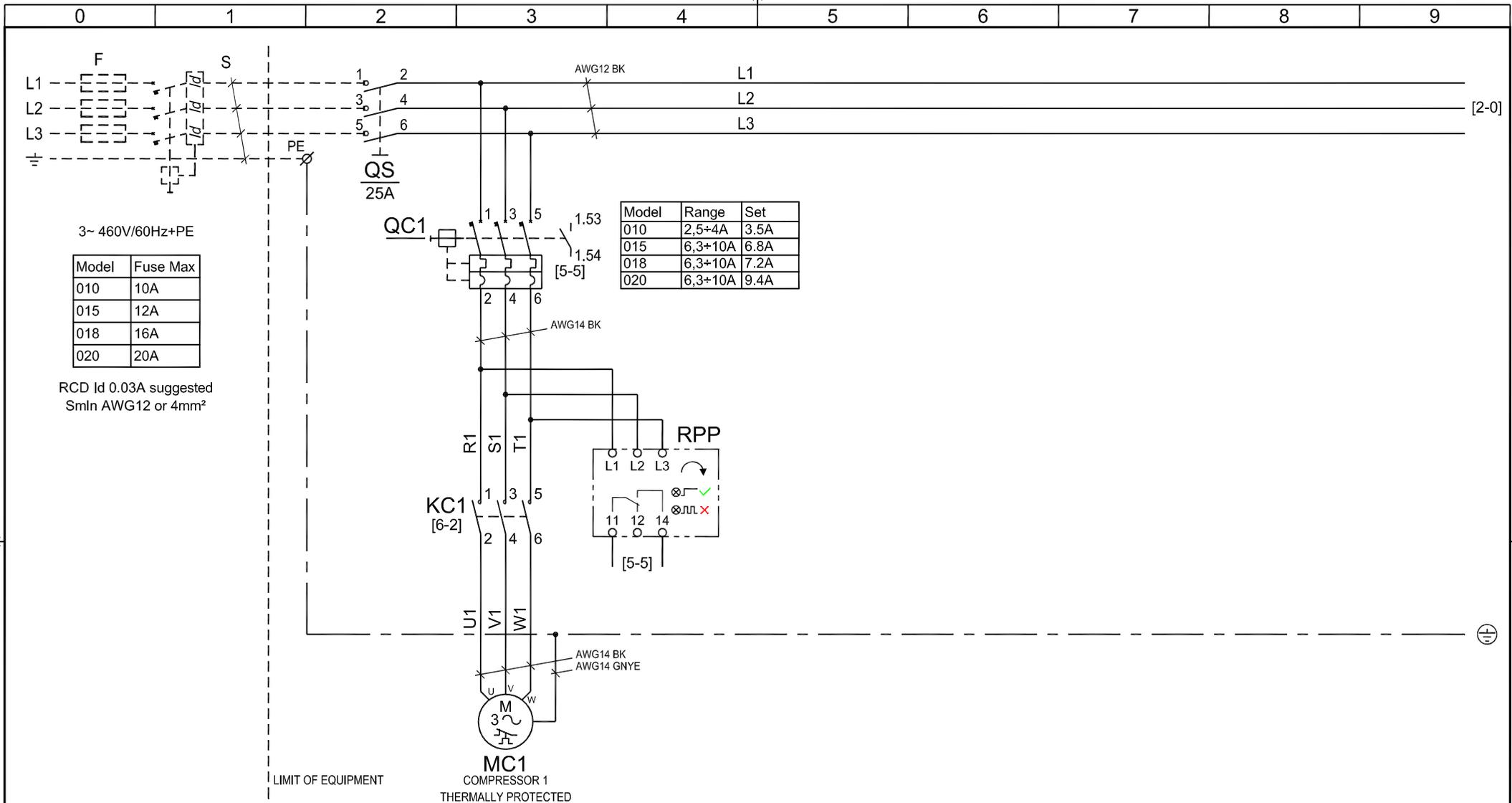

Technical modifications are subject to change without notice; errors not excluded



Titolo / Title :

SCHEMA ELETTRICO CWU010÷020 ELECTRICAL DIAGRAM CWU010÷020

FRIULAIR S.r.l. - 33050 CERVIGNANO DEL FRIULI (UD) - ITALY - Via Cisis, 36

Drawing no. :
FRCWU90CWU020R0000

Rev.
00

Note :

-

Sheet 1 of 10

COMPUTER AIDED DESIGN

This drawing cannot be reproduced, copied or given to third parties without FRIULAIR's written authorization

Questo disegno non può essere copiato, riprodotto né ceduto a terzi senza autorizzazione scritta della FRIULAIR S.r.l.

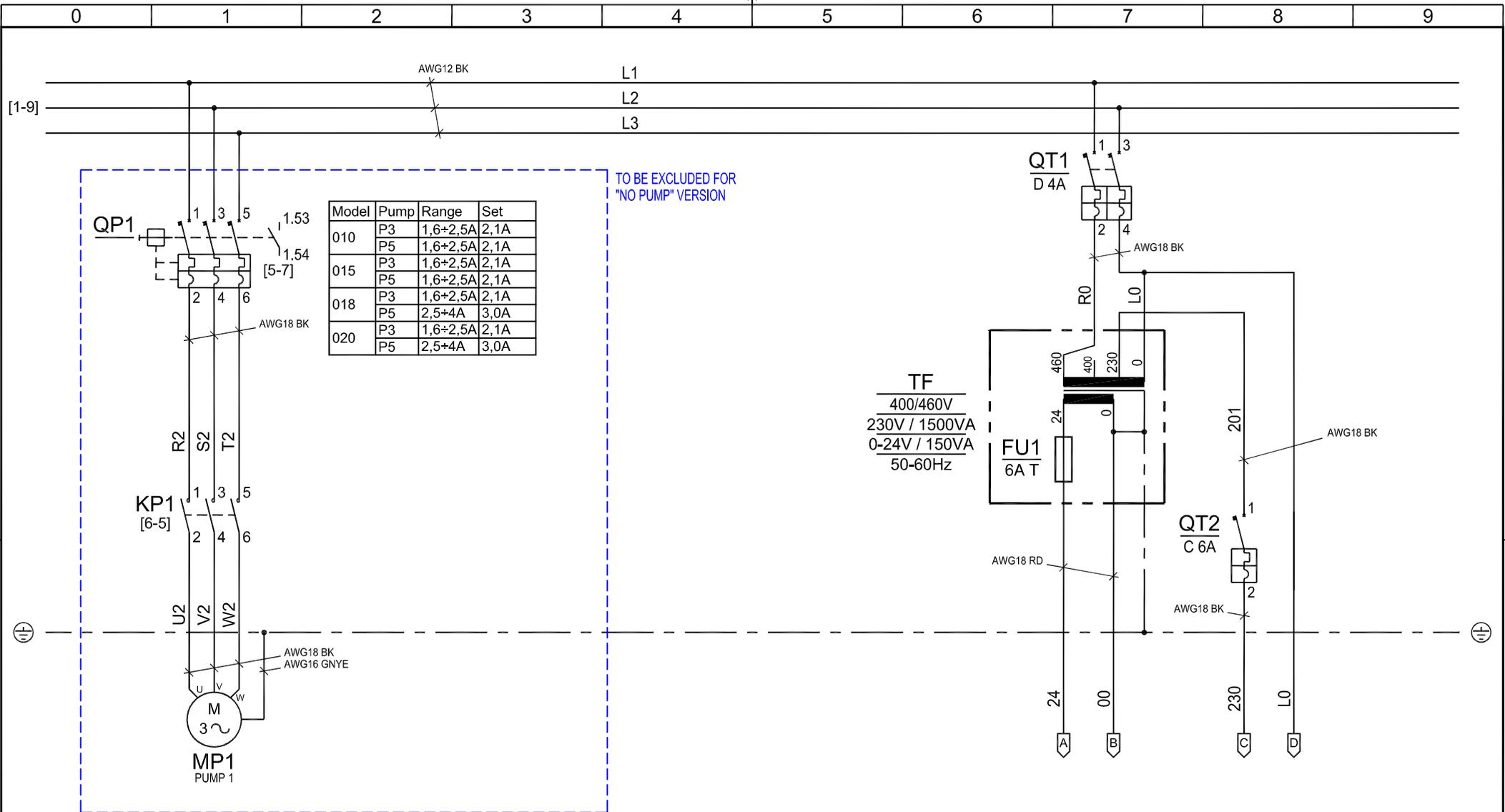

Technical modifications are subject to change without notice; errors not excluded



Titolo / Title :

SCHEMA ELETTRICO CWU010÷020 ELECTRICAL DIAGRAM CWU010÷020

FRIULAIR S.r.l. - 33050 CERVIGNANO DEL FRIULI (UD) - ITALY - Via Cisis, 36

Drawing no. : FRCWU90CWU020R0000

Rev. 00

Note :

-

Sheet 2 of 10

COMPUTER AIDED DESIGN

This drawing cannot be reproduced, copied or given to third parties without FRIULAIR's written authorization

Questo disegno non puo' essere copiato, riprodotto ne' ceduto a terzi senza autorizzazione scritta della FRIULAIR S.r.l.

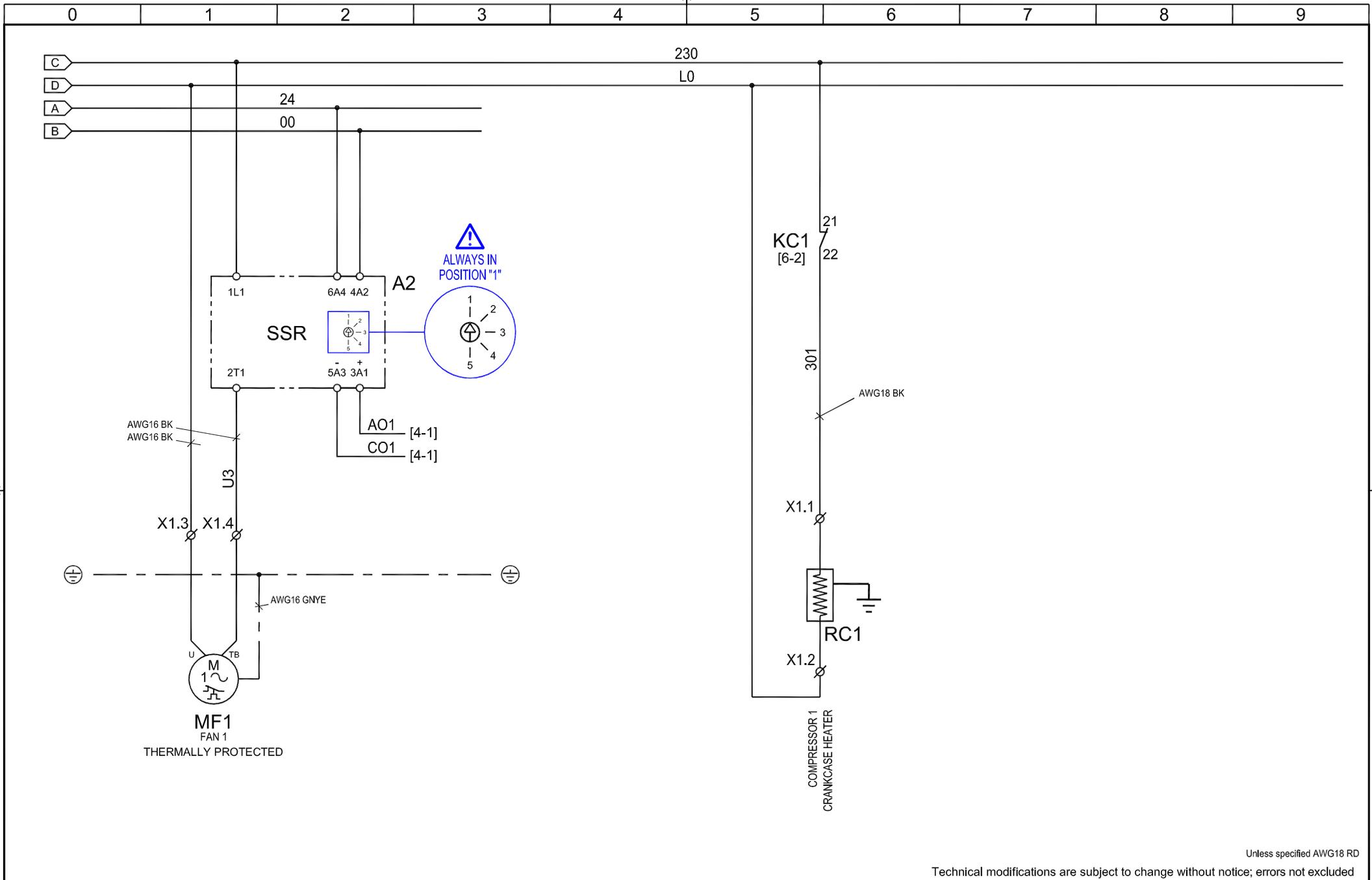

Unless specified AWG18 RD
 Technical modifications are subject to change without notice; errors not excluded

	Titolo / Title : SCHEMA ELETTRICO CWU010+020 ELECTRICAL DIAGRAM CWU010+020	Drawing no. : FRCWU90CWU020R0000	Rev. 00
	FRIULAIR S.r.l. - 33050 CERVIGNANO DEL FRIULI (UD) - ITALY - Via Cisis, 36	Note : -	Sheet 3 of 10

This drawing cannot be reproduced, copied or given to third parties without FRIULAIR's written authorization

Questo disegno non puo' essere copiato, riprodotto ne' ceduto a terzi senza autorizzazione scritta della FRIULAIR S.r.l.

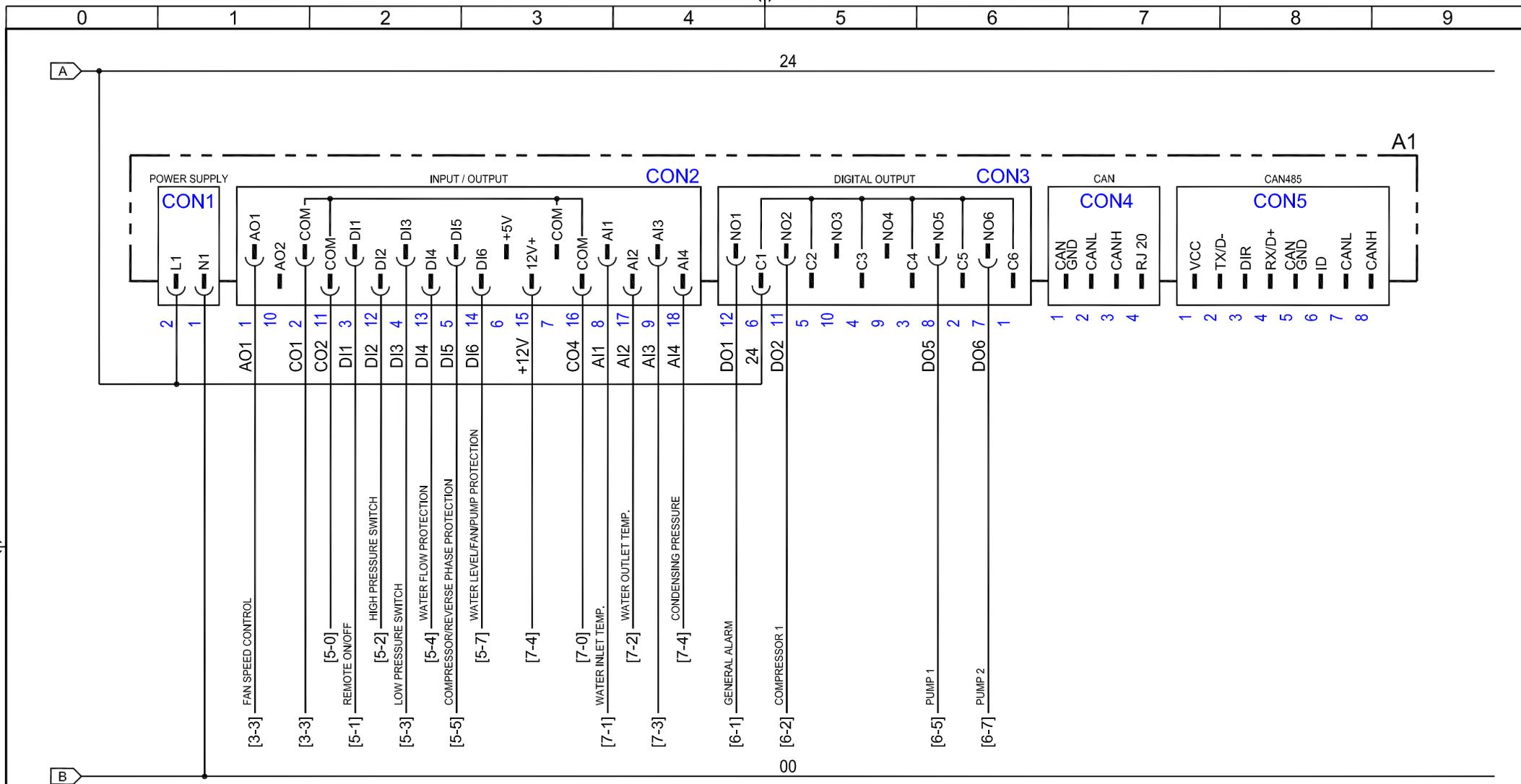

Technical modifications are subject to change without notice; errors not excluded



Titolo / Title : **SCHEMA ELETTRICO CWU010÷020**
ELECTRICAL DIAGRAM CWU010÷020
 FRIULAIR S.r.l. - 33050 CERVIGNANO DEL FRIULI (UD) - ITALY - Via Cisis, 36

Drawing no. : **FRCWU90CWU020R0000** Rev. **00**
 Note :
 - Sheet **4** of **10**

This drawing cannot be reproduced, copied or given to third parties without FRIULAIR's written authorization

Questo disegno non può essere copiato, riprodotto né ceduto a terzi senza autorizzazione scritta della FRIULAIR S.r.l.

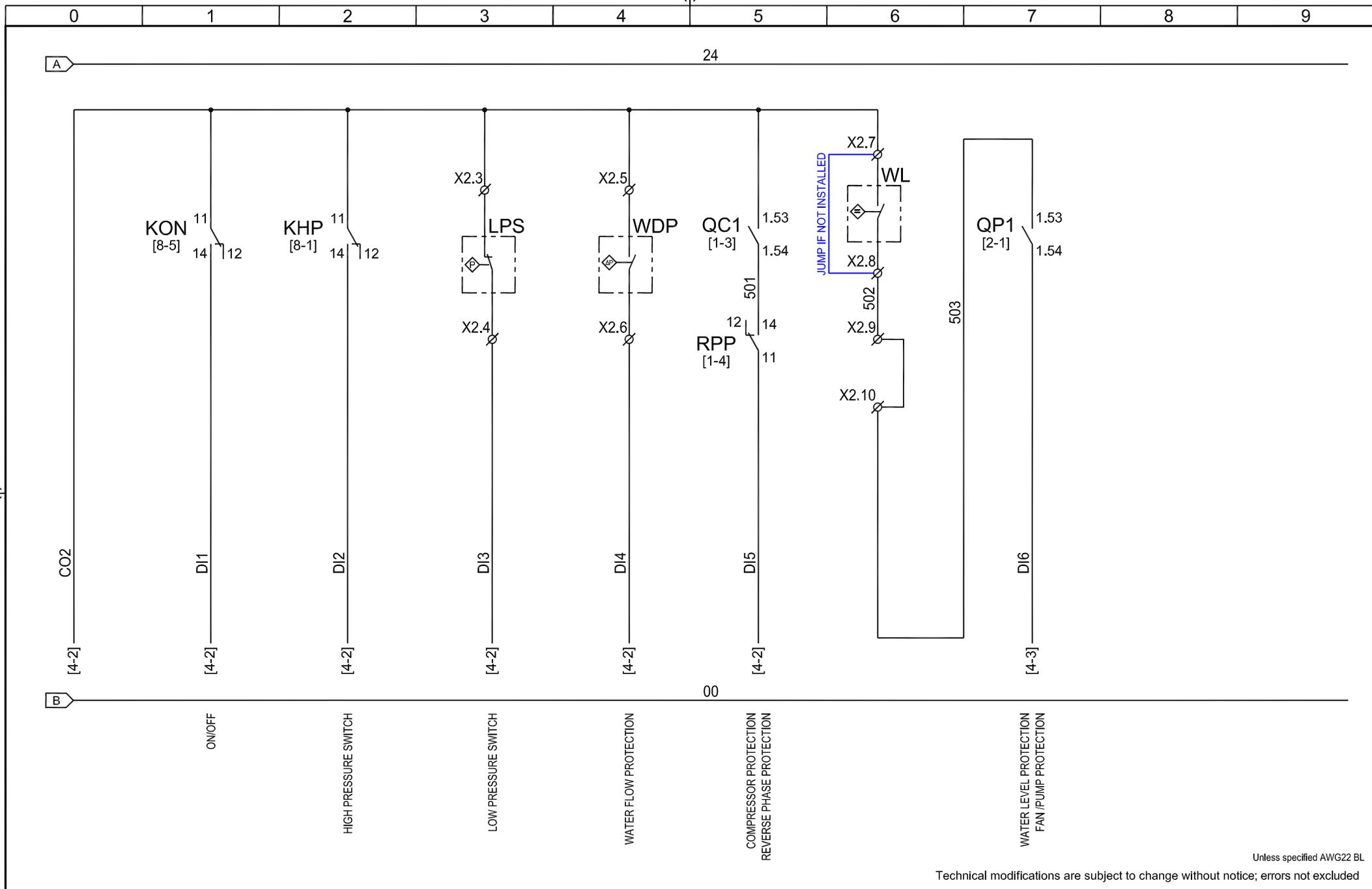

Unless specified AWG22 BL
Technical modifications are subject to change without notice; errors not excluded



Titolo / Title : **SCHEMA ELETTRICO CWU010÷020**
ELECTRICAL DIAGRAM CWU010÷020

FRIULAIR S.r.l. - 33050 CERVIGNANO DEL FRIULI (UD) - ITALY - Via Cisis, 36

Drawing no. : **FRCWU90CWU020R0000** Rev. **00**
 Note :
 -

Sheet **5** of **10**

This drawing cannot be reproduced, copied or given to third parties without FRIULAIR's written authorization

Questo disegno non può essere copiato, riprodotto né ceduto a terzi senza autorizzazione scritta della FRIULAIR S.r.l.

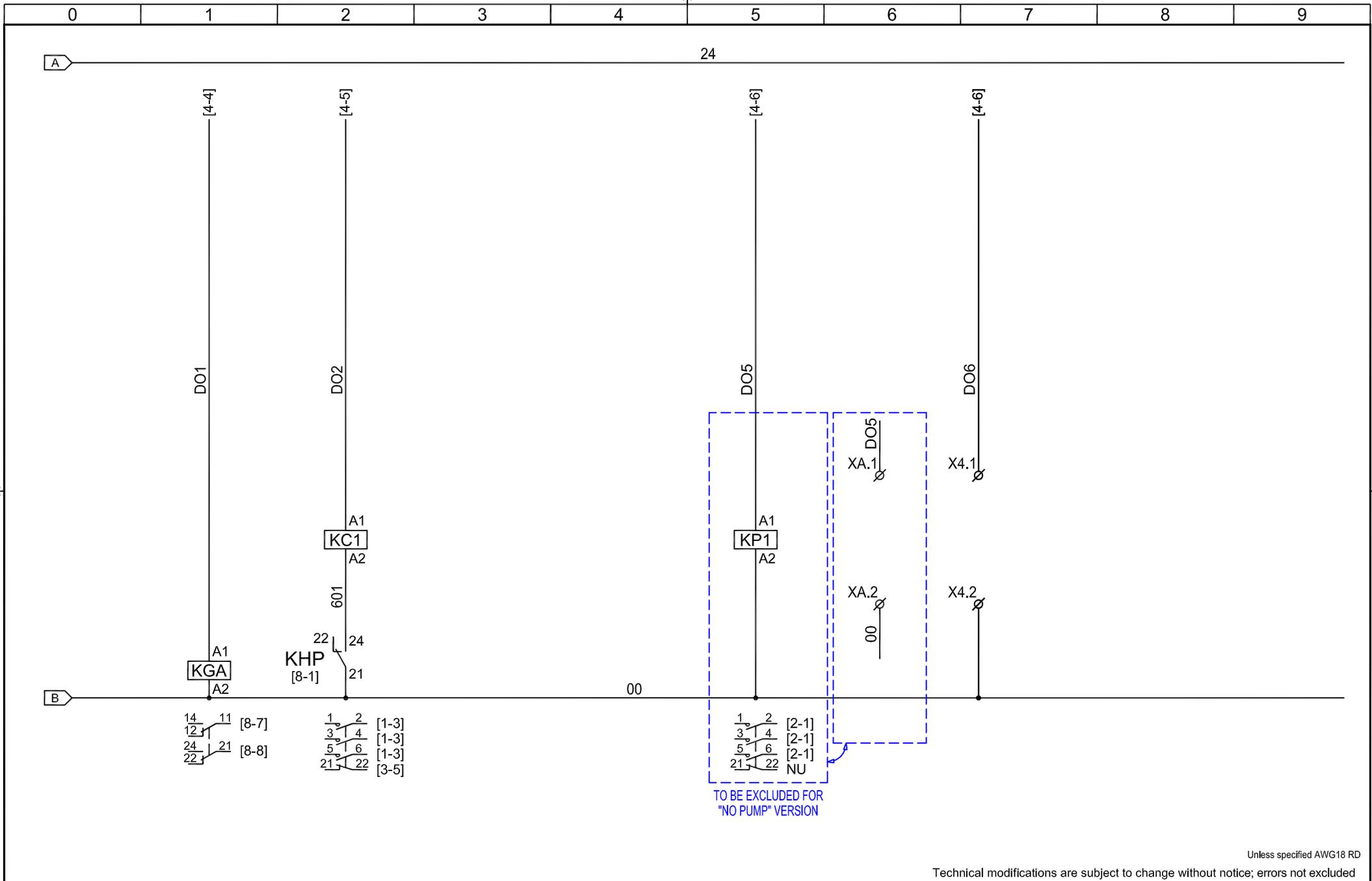

Unless specified AWG18 RD

Technical modifications are subject to change without notice; errors not excluded



Titolo / Title :

SCHEMA ELETTRICO CWU010÷020 ELECTRICAL DIAGRAM CWU010÷020

FRIULAIR S.r.l. - 33050 CERVIGNANO DEL FRIULI (UD) - ITALY - Via Cisis, 36

Drawing no. :

FRCWU90CWU020R0000

Rev.

00

Note :

-

Sheet 6 of 10

COMPUTER AIDED DESIGN

This drawing cannot be reproduced, copied or given to third parties without FRIULAIR's written authorization

Questo disegno non può essere copiato, riprodotto né ceduto a terzi senza autorizzazione scritta della FRIULAIR S.r.l.

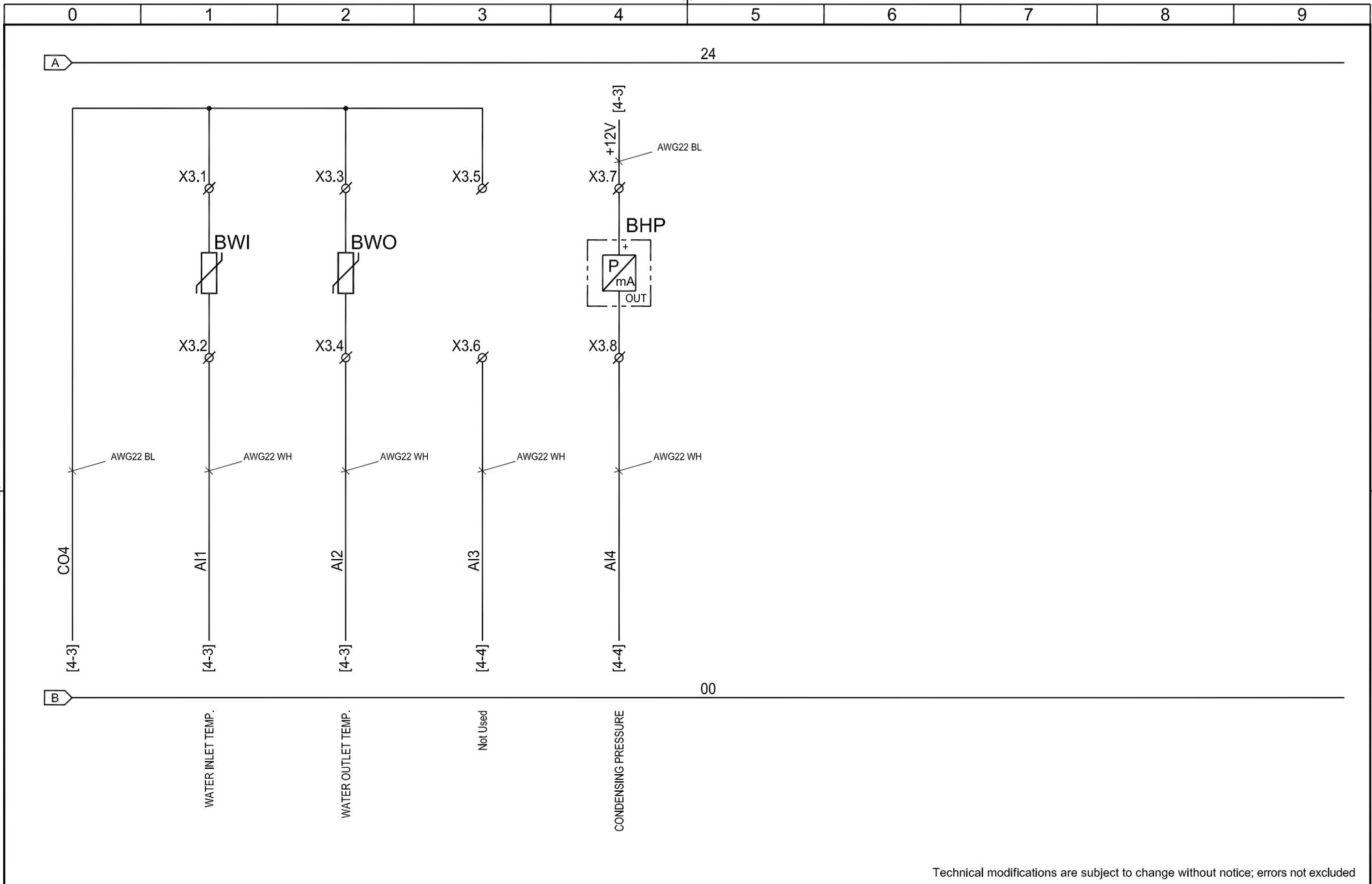

Technical modifications are subject to change without notice; errors not excluded



Titolo / Title :

SCHEMA ELETTRICO CWU010÷020 ELECTRICAL DIAGRAM CWU010÷020

FRIULAIR S.r.l. - 33050 CERVIGNANO DEL FRIULI (UD) - ITALY - Via Cisis, 36

Drawing no. : FRCWU90CWU020R0000

Rev. 00

Note :

-

Sheet 7 of 10

COMPUTER AIDED DESIGN

This drawing cannot be reproduced, copied or given to third parties without FRIULAIR's written authorization

Questo disegno non può essere copiato, riprodotto né ceduto a terzi senza autorizzazione scritta della FRIULAIR S.r.l.

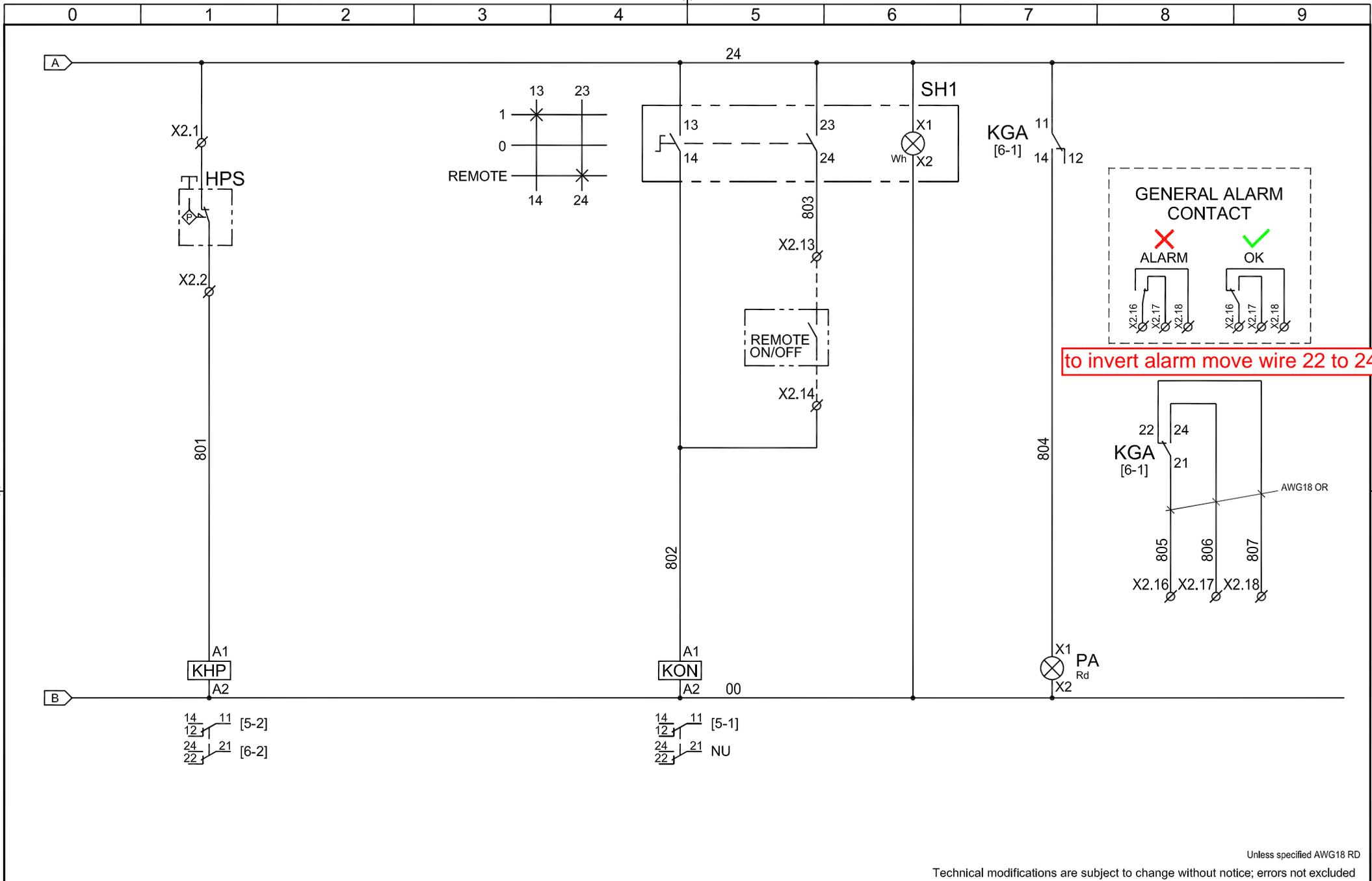

Unless specified AWG18 RD
Technical modifications are subject to change without notice; errors not excluded



Titolo / Title : **SCHEMA ELETTRICO CWU010÷020**
ELECTRICAL DIAGRAM CWU010÷020

FRIULAIR S.r.l. - 33050 CERVIGNANO DEL FRIULI (UD) - ITALY - Via Cisis, 36

Drawing no. : **FRCWU90CWU020R0000** Rev. **00**

Note :
-

Sheet **8** of **10**

This drawing cannot be reproduced, copied or given to third parties without FRIULAIR's written authorization

Questo disegno non può essere copiato, riprodotto né ceduto a terzi senza autorizzazione scritta della FRIULAIR S.r.l.

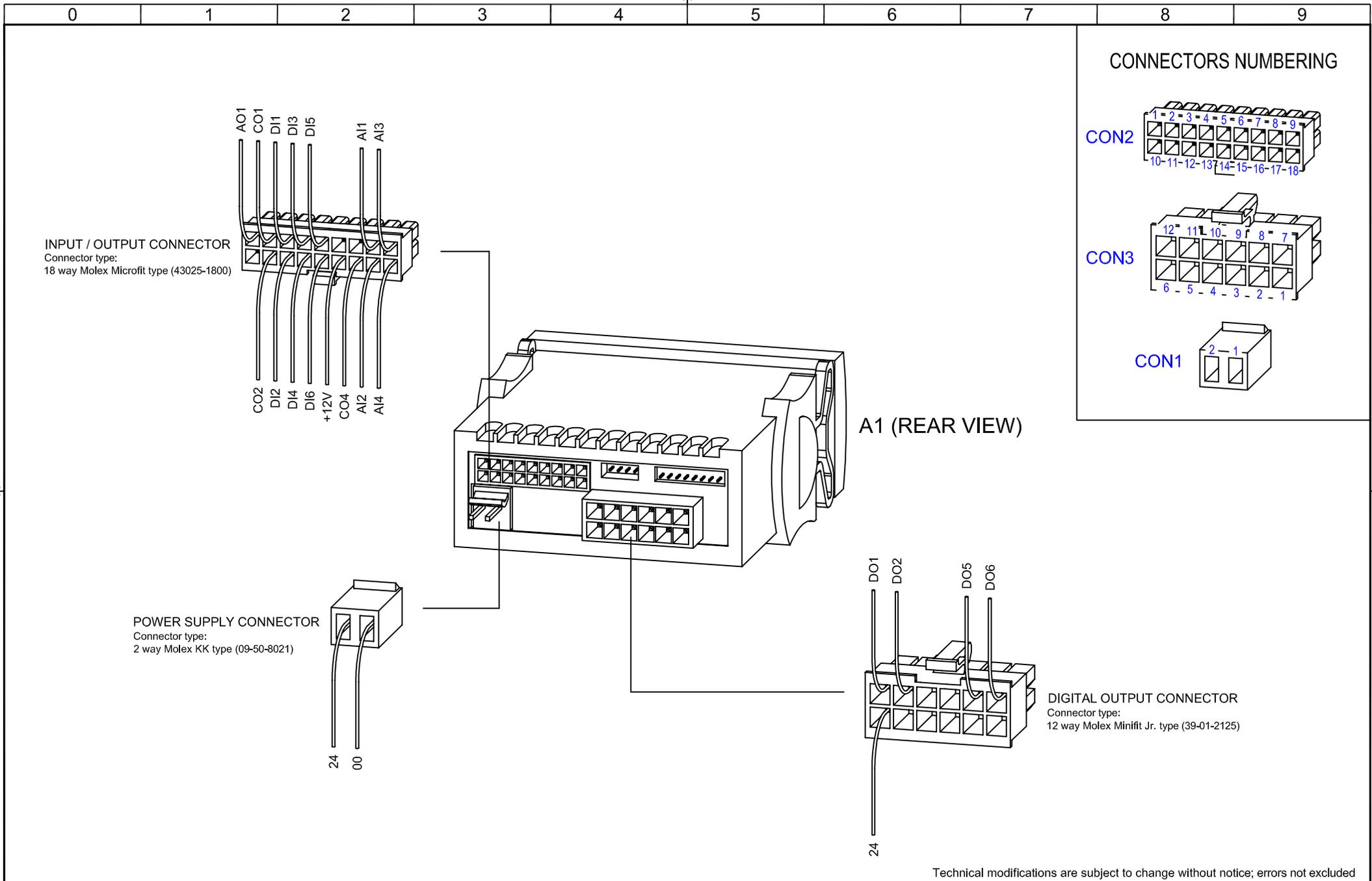

Technical modifications are subject to change without notice; errors not excluded



Titolo / Title :

SCHEMA ELETTRICO CWU010÷020
ELECTRICAL DIAGRAM CWU010÷020

FRIULAIR S.r.l. - 33050 CERVIGNANO DEL FRIULI (UD) - ITALY - Via Cisis, 36

Drawing no. : **FRCWU90CWU020R0000**

Rev. **00**

Note :

-

Sheet **10** of **10**

COMPUTER AIDED DESIGN

Titolo - Title

SCHEMA ELETTRICO CWU030 ELECTRICAL DIAGRAM CWU030

Disegno n° - Drawing nr.

FRCWU90CWU030R0000

Revisione - Revision

02

This drawing cannot be reproduced, copied or given to third parties without FRIULAIR's written authorization

Questo disegno non può essere copiato, riprodotto né ceduto a terzi senza autorizzazione scritta della FRIULAIR S.r.l.

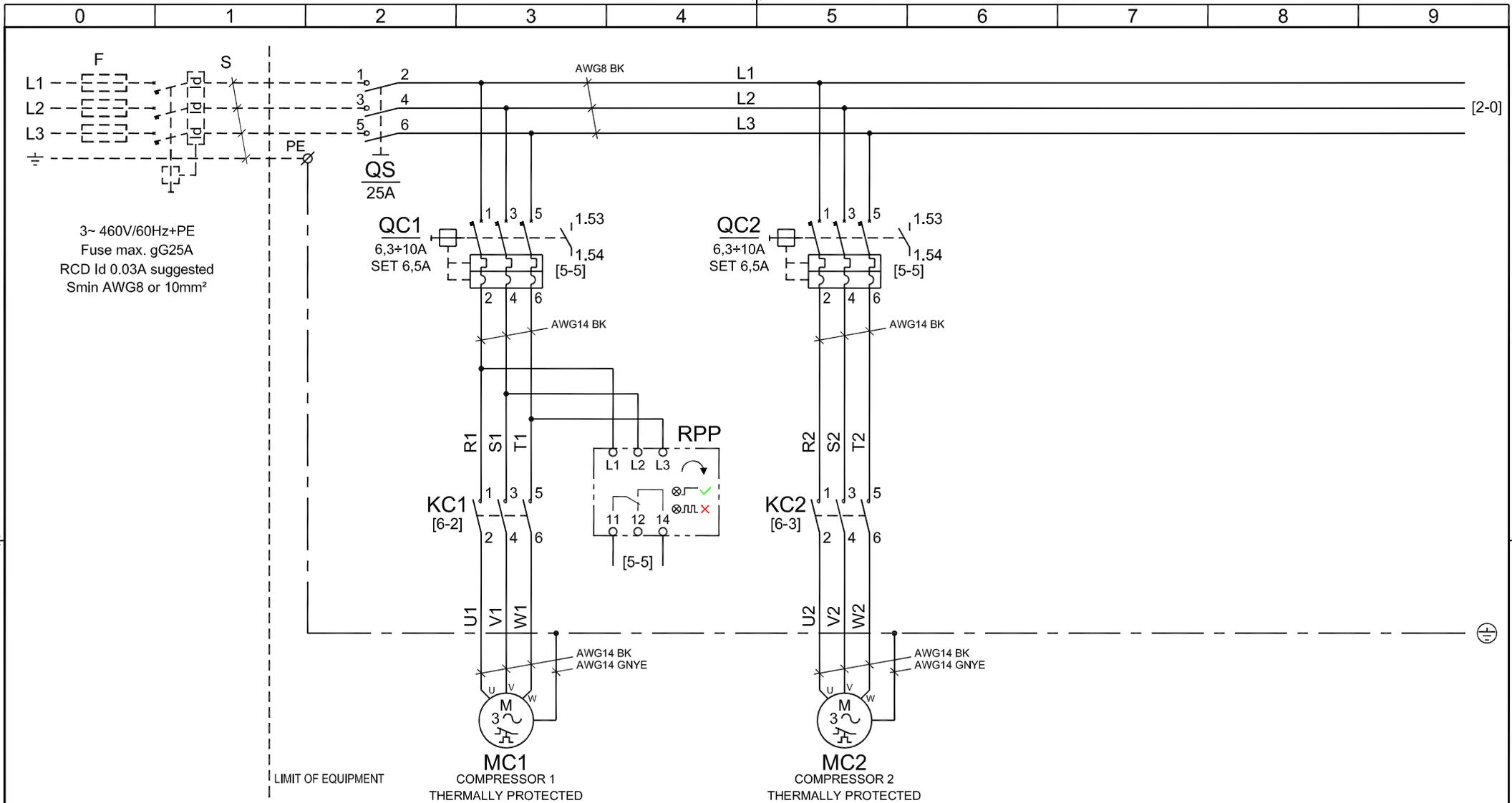

Technical modifications are subject to change without notice; errors not excluded



Titolo / Title :

SCHEMA ELETTRICO CWU030 ELECTRICAL DIAGRAM CWU030

FRIULAIR S.r.l. - 33050 CERVIGNANO DEL FRIULI (UD) - ITALY - Via Cisis, 36

Drawing no. :
FRCWU90CWU030R0000

Rev.
02

Note :

-

Sheet 1 of 10

COMPUTER AIDED DESIGN

This drawing cannot be reproduced, copied or given to third parties without FRIULAIR's written authorization

Questo disegno non può essere copiato, riprodotto né ceduto a terzi senza autorizzazione scritta della FRIULAIR S.r.l.

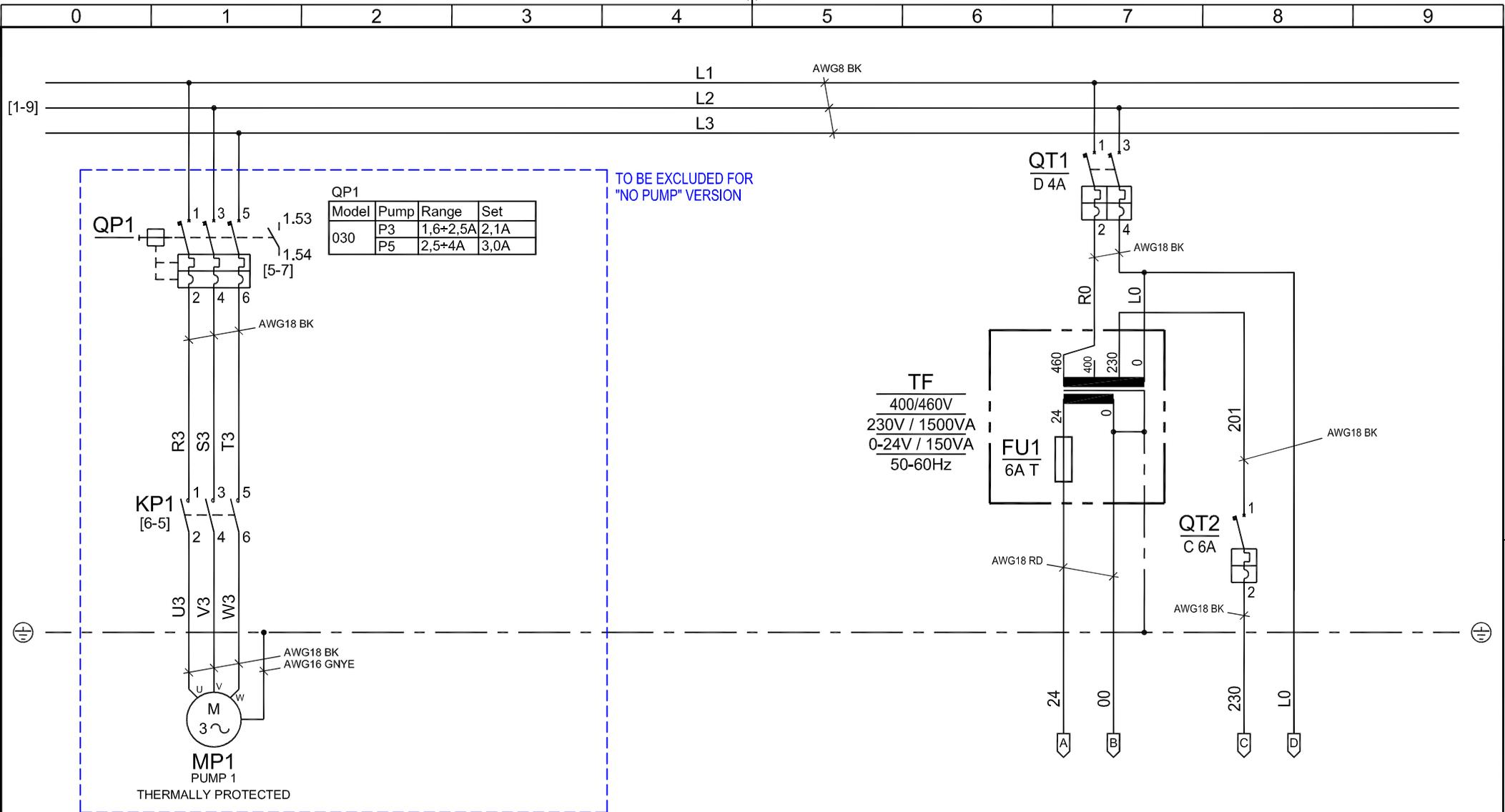

Technical modifications are subject to change without notice; errors not excluded

FRIULAIR
Dryers

Titolo / Title :

SCHEMA ELETTRICO CWU030
ELECTRICAL DIAGRAM CWU030

FRIULAIR S.r.l. - 33050 CERVIGNANO DEL FRIULI (UD) - ITALY - Via Cisis, 36

Drawing no. :
FRCWU90CWU030R0000

Rev.
02

Note :

-

Sheet **2** of **10**

COMPUTER AIDED DESIGN

This drawing cannot be reproduced, copied or given to third parties without FRIULAIR's written authorization

Questo disegno non può essere copiato, riprodotto né ceduto a terzi senza autorizzazione scritta della FRIULAIR S.r.l.

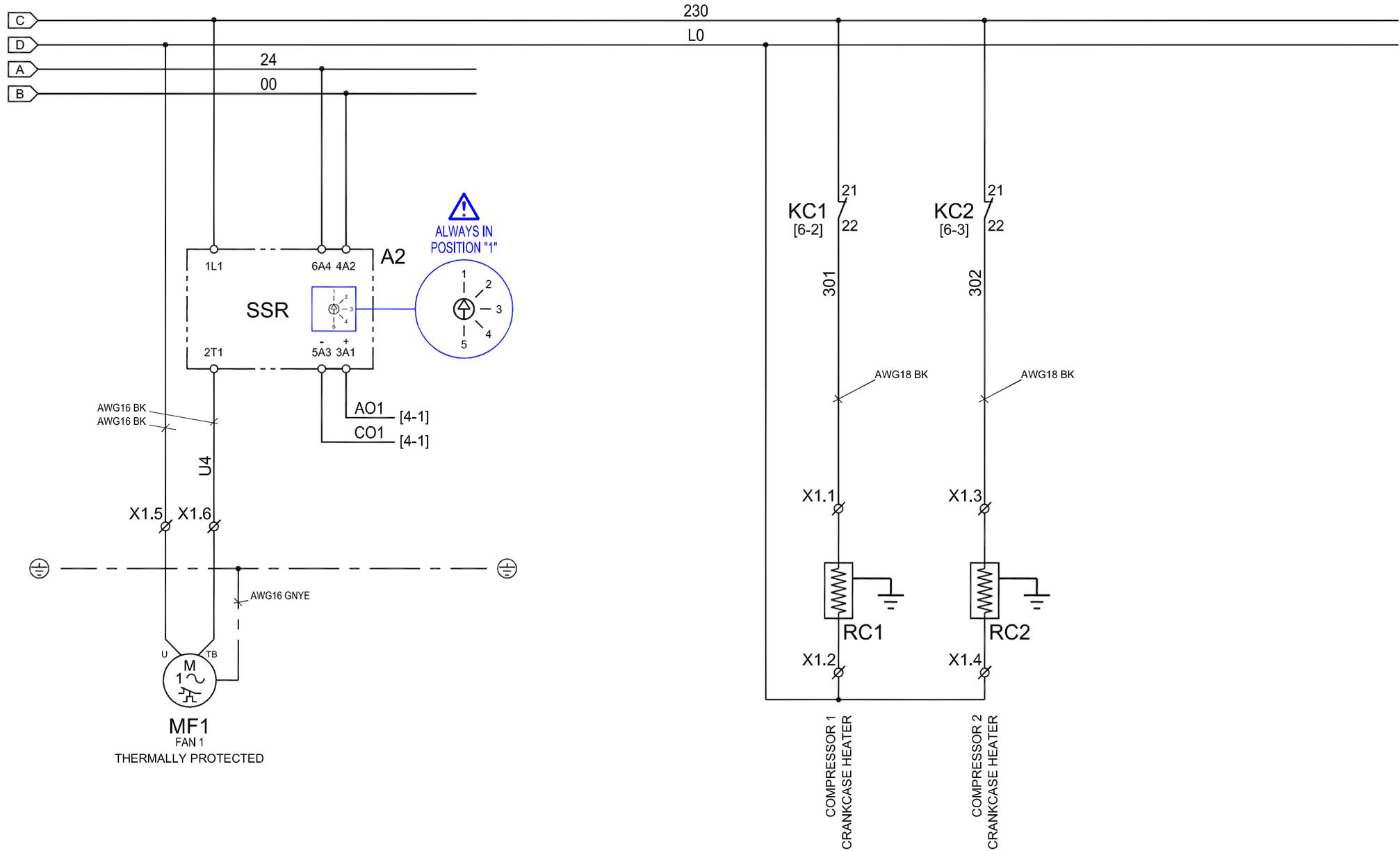

Unless specified AWG18 RD
 Technical modifications are subject to change without notice; errors not excluded



Titolo / Title : **SCHEMA ELETTRICO CWU030**
ELECTRICAL DIAGRAM CWU030
 FRIULAIR S.r.l. - 33050 CERVIGNANO DEL FRIULI (UD) - ITALY - Via Cisis, 36

Drawing no. : **FRCWU90CWU030R0000** Rev. **02**
 Note :
 - Sheet **3** of **10**

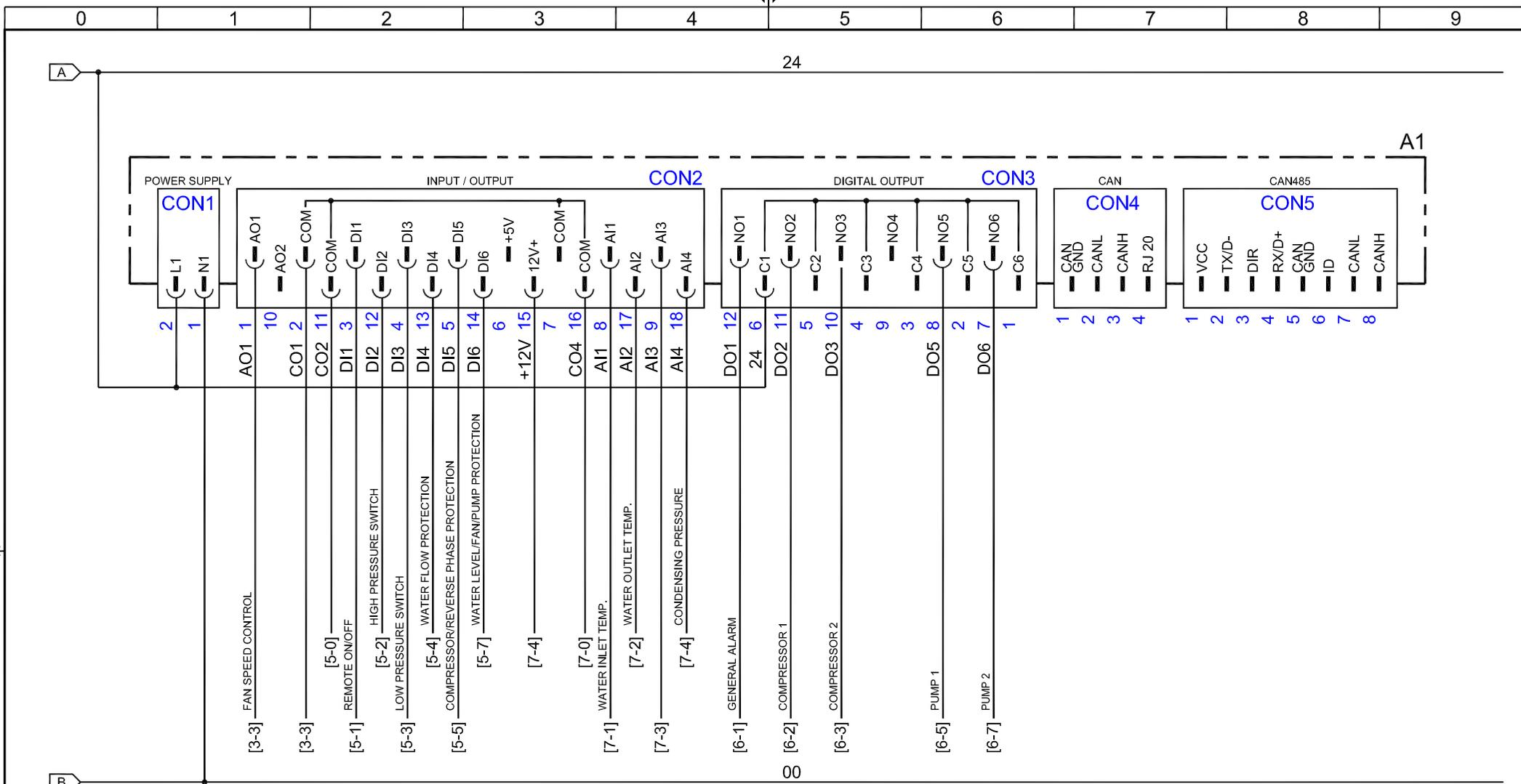

Technical modifications are subject to change without notice; errors not excluded



Titolo / Title :

SCHEMA ELETTRICO CWU030 ELECTRICAL DIAGRAM CWU030

FRIULAIR S.r.l. - 33050 CERVIGNANO DEL FRIULI (UD) - ITALY - Via Cisis, 36

Drawing no. : FRCWU90CWU030R0000

Rev. 02

Note :

-

Sheet 4 of 10

This drawing cannot be reproduced, copied or given to third parties without FRIULAIR's written authorization

Questo disegno non può essere copiato, riprodotto né ceduto a terzi senza autorizzazione scritta della FRIULAIR S.r.l.

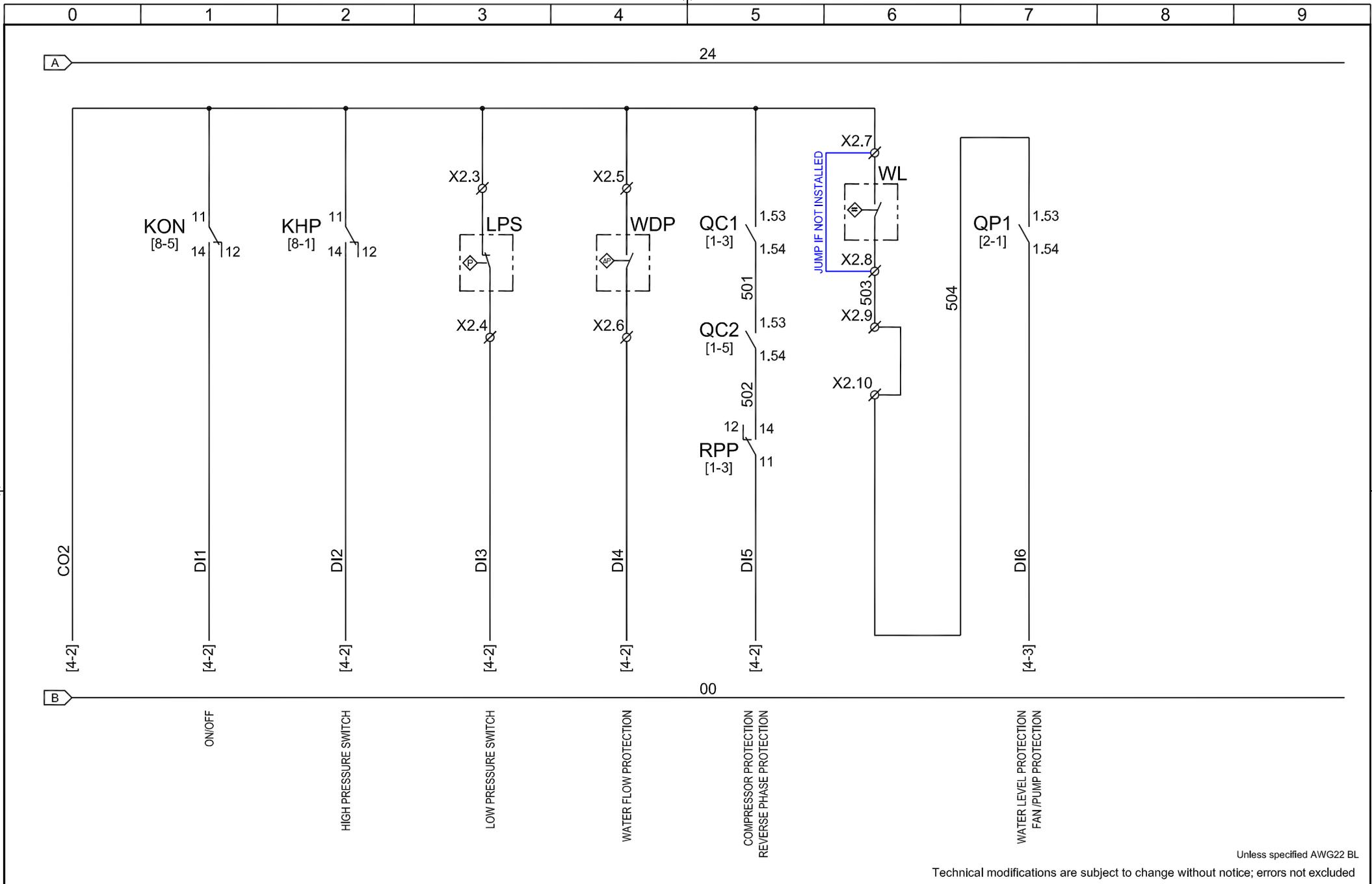

Unless specified AWG22 BL

Technical modifications are subject to change without notice; errors not excluded



Titolo / Title :

**SCHEMA ELETTRICO CWU030
ELECTRICAL DIAGRAM CWU030**

FRIULAIR S.r.l. - 33050 CERVIGNANO DEL FRIULI (UD) - ITALY - Via Cisis, 36

Drawing no. : **FRCWU90CWU030R0000**

Rev. **02**

Note :

-

Sheet **5** of **10**

COMPUTER AIDED DESIGN

This drawing cannot be reproduced, copied or given to third parties without FRIULAIR's written authorization

Questo disegno non può essere copiato, riprodotto né ceduto a terzi senza autorizzazione scritta della FRIULAIR S.r.l.

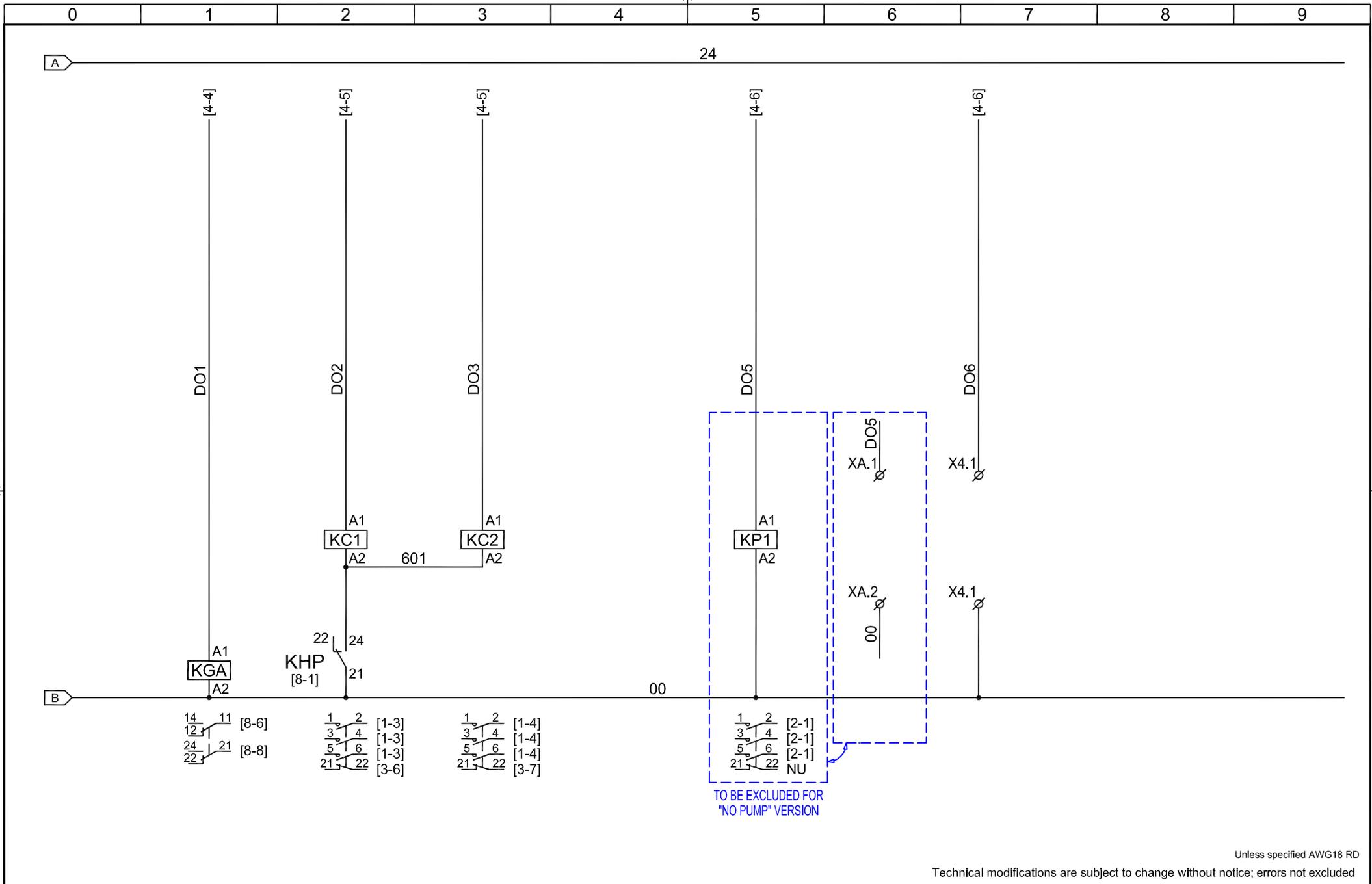

Unless specified AWG18 RD
 Technical modifications are subject to change without notice; errors not excluded



Titolo / Title : **SCHEMA ELETTRICO CWU030**
ELECTRICAL DIAGRAM CWU030
 FRIULAIR S.r.l. - 33050 CERVIGNANO DEL FRIULI (UD) - ITALY - Via Cisis, 36

Drawing no. : **FRCWU90CWU030R0000** Rev. **02**
 Note :
 - Sheet **6** of **10**

This drawing cannot be reproduced, copied or given to third parties without FRIULAIR's written authorization

Questo disegno non può essere copiato, riprodotto né ceduto a terzi senza autorizzazione scritta della FRIULAIR S.r.l.

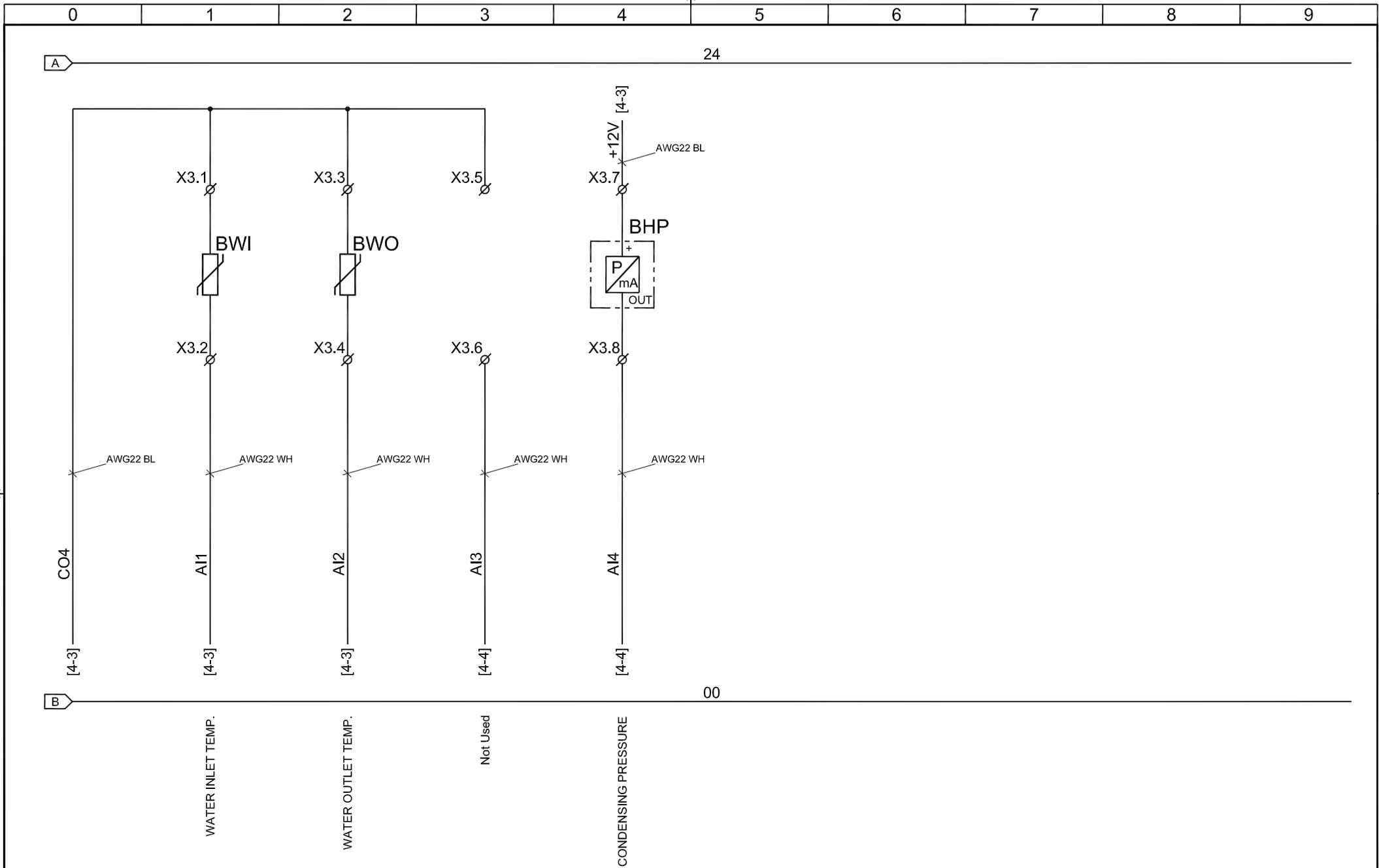

Technical modifications are subject to change without notice; errors not excluded



Titolo / Title :

SCHEMA ELETTRICO CWU030 ELECTRICAL DIAGRAM CWU030

FRIULAIR S.r.l. - 33050 CERVIGNANO DEL FRIULI (UD) - ITALY - Via Cisis, 36

Drawing no. :
FRCWU90CWU030R0000

Rev.
02

Note :

-

Sheet **7** of **10**

COMPUTER AIDED DESIGN

This drawing cannot be reproduced, copied or given to third parties without FRIULAIR's written authorization

Questo disegno non può essere copiato, riprodotto né ceduto a terzi senza autorizzazione scritta della FRIULAIR S.r.l.

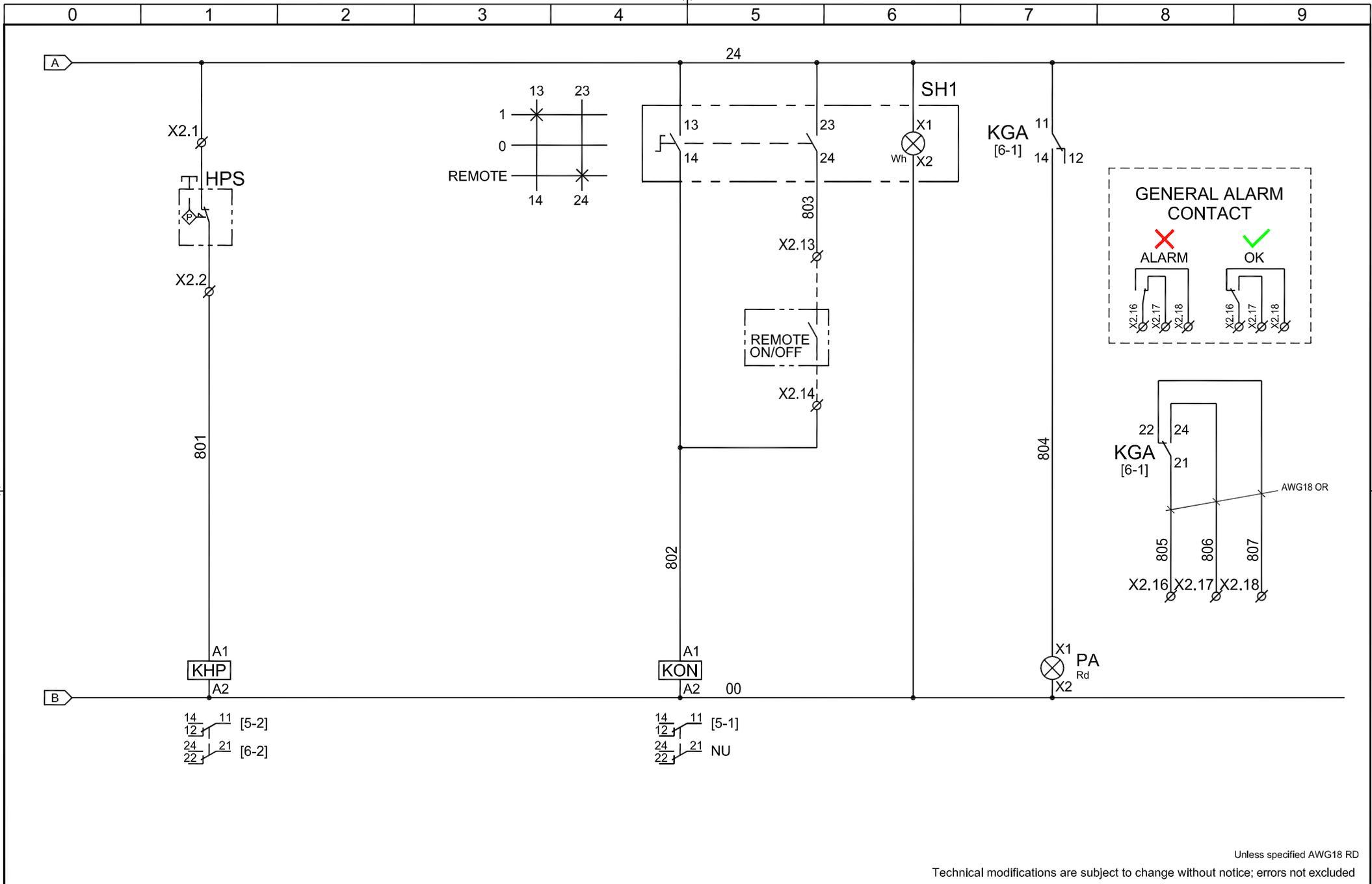

Unless specified AWG18 RD
 Technical modifications are subject to change without notice; errors not excluded



Titolo / Title : **SCHEMA ELETTRICO CWU030**
ELECTRICAL DIAGRAM CWU030
 FRIULAIR S.r.l. - 33050 CERVIGNANO DEL FRIULI (UD) - ITALY - Via Cisis, 36

Drawing no. : **FRCWU90CWU030R0000** Rev. **02**
 Note :
 - Sheet **8** of **10**
 COMPUTER AIDED DESIGN

This drawing cannot be reproduced, copied or given to third parties without FRIULAIR's written authorization

Questo disegno non può essere copiato, riprodotto né ceduto a terzi senza autorizzazione scritta della FRIULAIR S.r.l.

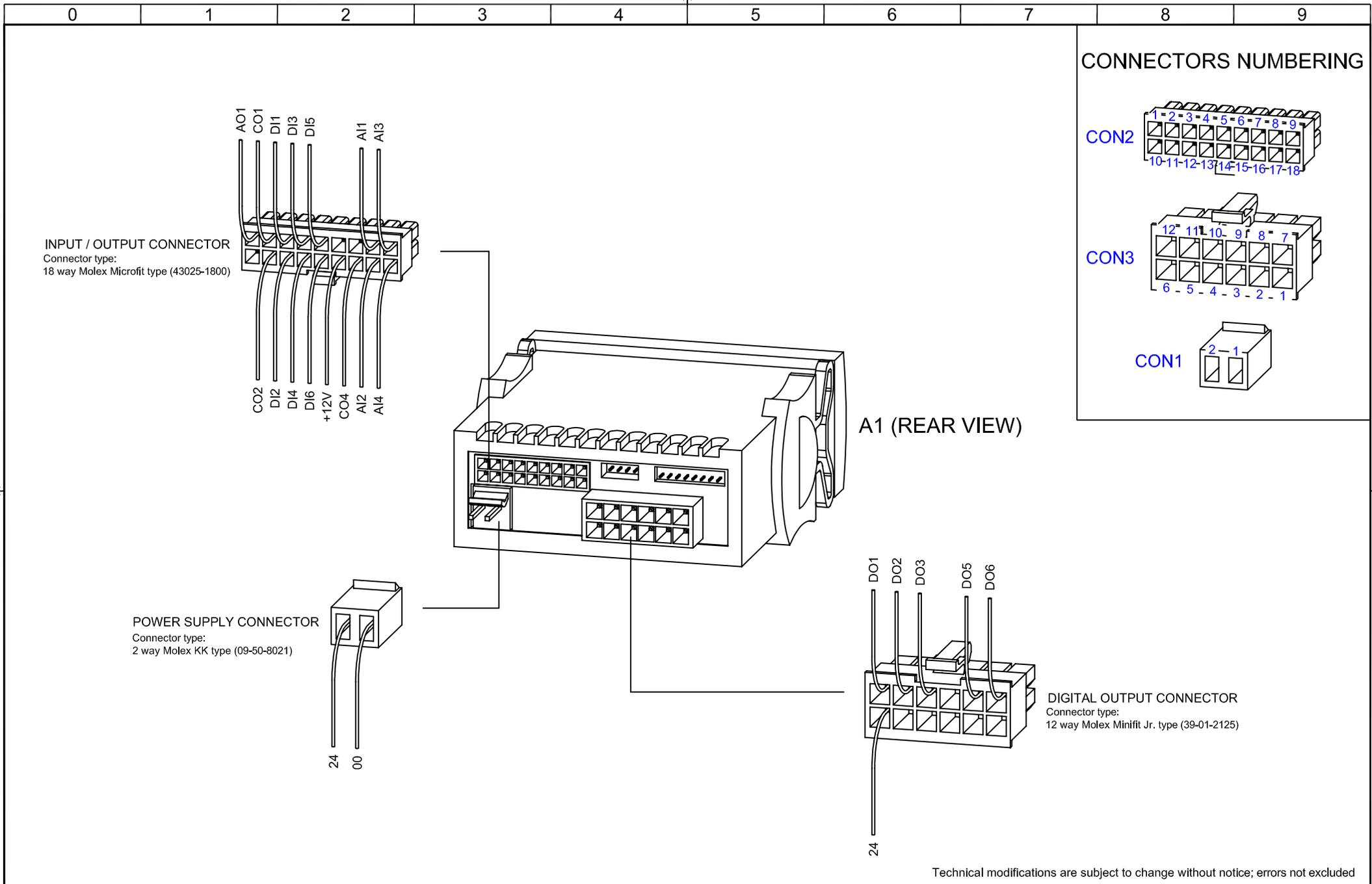

Technical modifications are subject to change without notice; errors not excluded



Titolo / Title : **SCHEMA ELETTRICO CWU030**
ELECTRICAL DIAGRAM CWU030

FRIULAIR S.r.l. - 33050 CERVIGNANO DEL FRIULI (UD) - ITALY - Via Cisis, 36

Drawing no. : **FRCWU90CWU030R0000** Rev. **02**

Note : -

Sheet **10** of **10**

This drawing cannot be reproduced, copied or given to
third parties without FRIULAIR's written authorization

Questo disegno non può essere copiato, riprodotto né ceduto
a terzi senza autorizzazione scritta della FRIULAIR S.r.l.

Titolo - Title

SCHEMA ELETTRICO CWU038÷040
ELECTRICAL DIAGRAM CWU038÷040

Disegno n° - Drawing nr.

FRCWU90CWU040R0000

Revisione - Revision

00

FRIULAIR
Dryers

FRIULAIR S.r.l. - 33050 CERVIGNANO DEL FRIULI (UD) - ITALY - Via Cisis, 36

This drawing cannot be reproduced, copied or given to third parties without FRIULAIR's written authorization

Questo disegno non può essere copiato, riprodotto né ceduto a terzi senza autorizzazione scritta della FRIULAIR S.r.l.

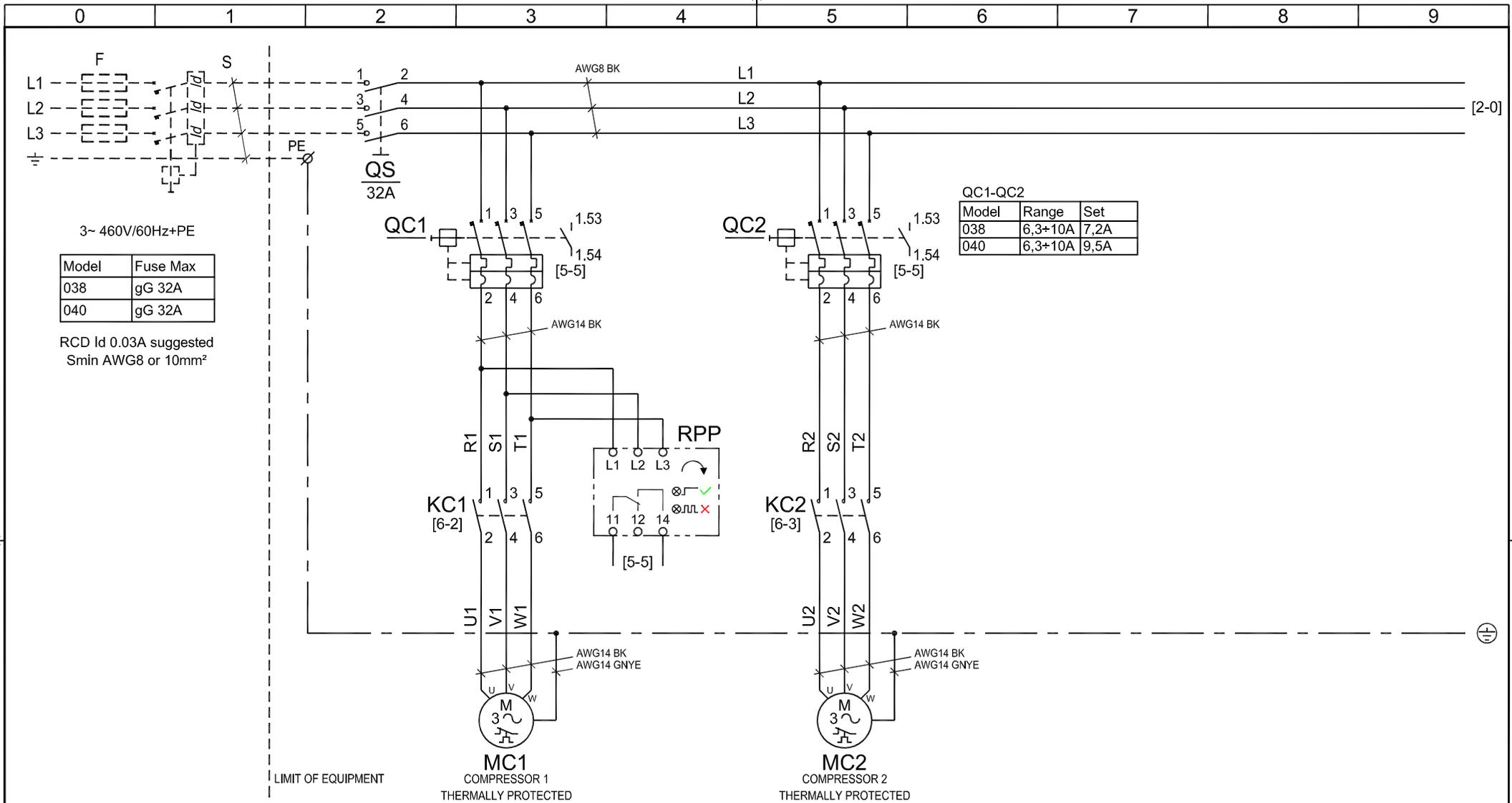

Technical modifications are subject to change without notice; errors not excluded

FRIULAIR
Dryers

Titolo / Title :

SCHEMA ELETTRICO CWU038+040
ELECTRICAL DIAGRAM CWU038+040

FRIULAIR S.r.l. - 33050 CERVIGNANO DEL FRIULI (UD) - ITALY - Via Cisis, 36

Drawing no. :

FRCWU90CWU040R0000

Rev.

00

Note :

-

Sheet 1 of 10

COMPUTER AIDED DESIGN

This drawing cannot be reproduced, copied or given to third parties without FRIULAIR's written authorization

Questo disegno non può essere copiato, riprodotto né ceduto a terzi senza autorizzazione scritta della FRIULAIR S.r.l.

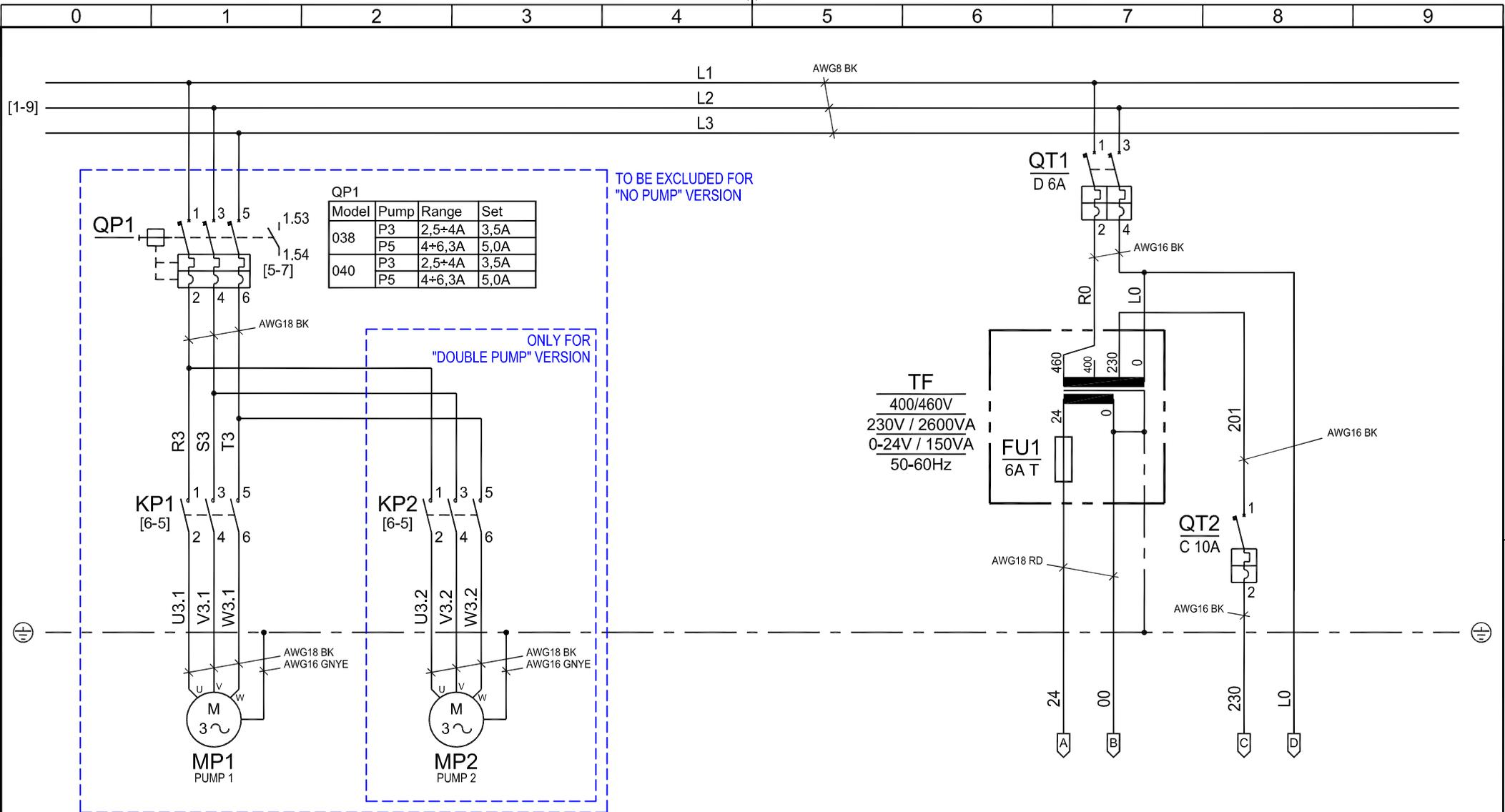

Technical modifications are subject to change without notice; errors not excluded



Titolo / Title :

SCHEMA ELETTRICO CWU038+040 ELECTRICAL DIAGRAM CWU038+040

FRIULAIR S.r.l. - 33050 CERVIGNANO DEL FRIULI (UD) - ITALY - Via Cisis, 36

Drawing no. : FRCWU90CWU040R0000

Rev. 00

Note :

-

Sheet 2 of 10

COMPUTER AIDED DESIGN

This drawing cannot be reproduced, copied or given to third parties without FRIULAIR's written authorization

Questo disegno non può essere copiato, riprodotto né ceduto a terzi senza autorizzazione scritta della FRIULAIR S.r.l.

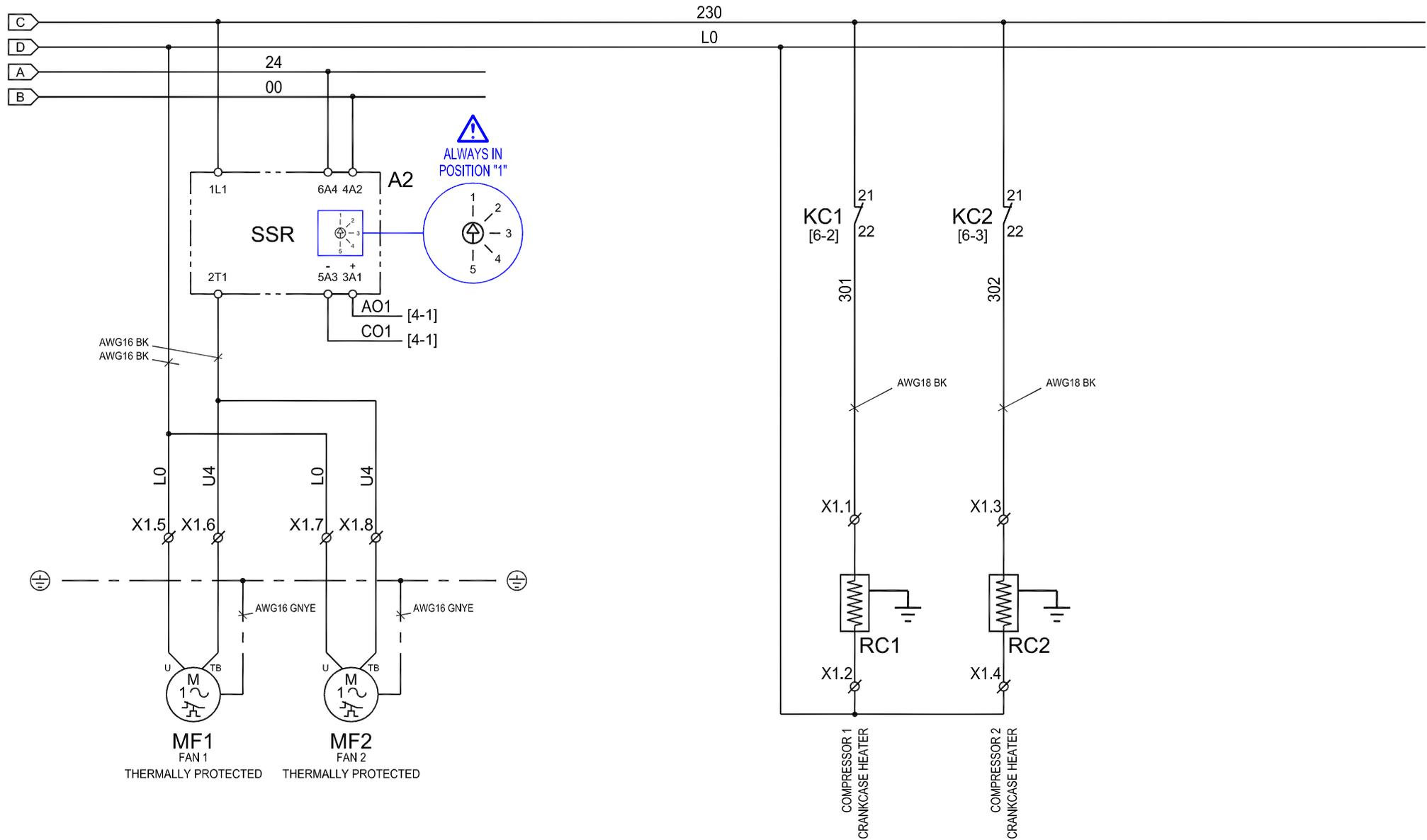

Unless specified AWG18 RD
 Technical modifications are subject to change without notice; errors not excluded



Titolo / Title :

SCHEMA ELETTRICO CWU038+040 ELECTRICAL DIAGRAM CWU038+040

FRIULAIR S.r.l. - 33050 CERVIGNANO DEL FRIULI (UD) - ITALY - Via Cisis, 36

Drawing no. :
FRCWU90CWU040R0000

Rev.
00

Note :

-

Sheet **3** of **10**

COMPUTER AIDED DESIGN

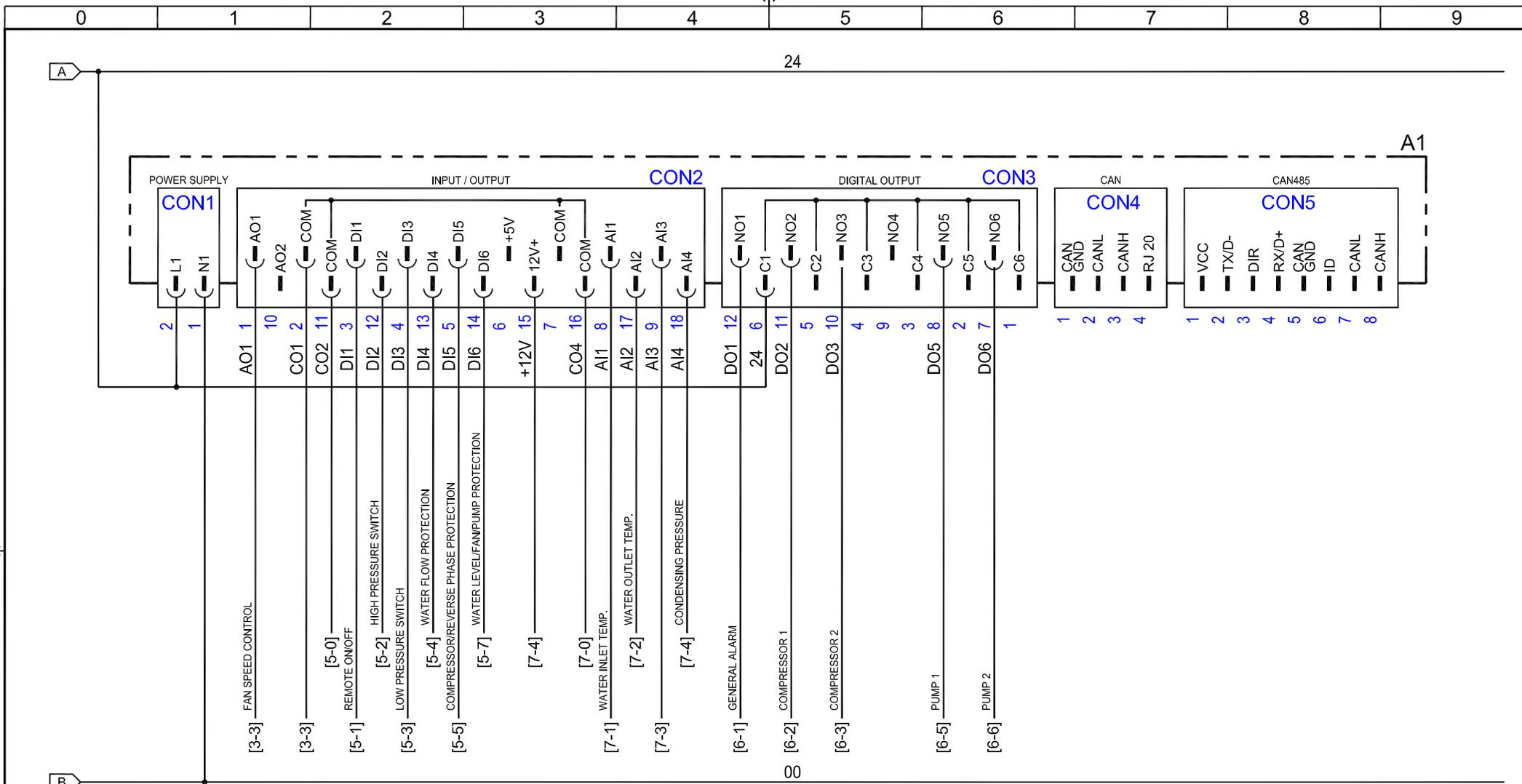

Technical modifications are subject to change without notice; errors not excluded



Titolo / Title :

SCHEMA ELETTRICO CWU038+040 ELECTRICAL DIAGRAM CWU038+040

FRIULAIR S.r.l. - 33050 CERVIGNANO DEL FRIULI (UD) - ITALY - Via Cisis, 36

Drawing no. : FRCWU90CWU040R0000

Rev. 00

Note :

-

Sheet 4 of 10

This drawing cannot be reproduced, copied or given to third parties without FRIULAIR's written authorization

Questo disegno non può essere copiato, riprodotto né ceduto a terzi senza autorizzazione scritta della FRIULAIR S.r.l.

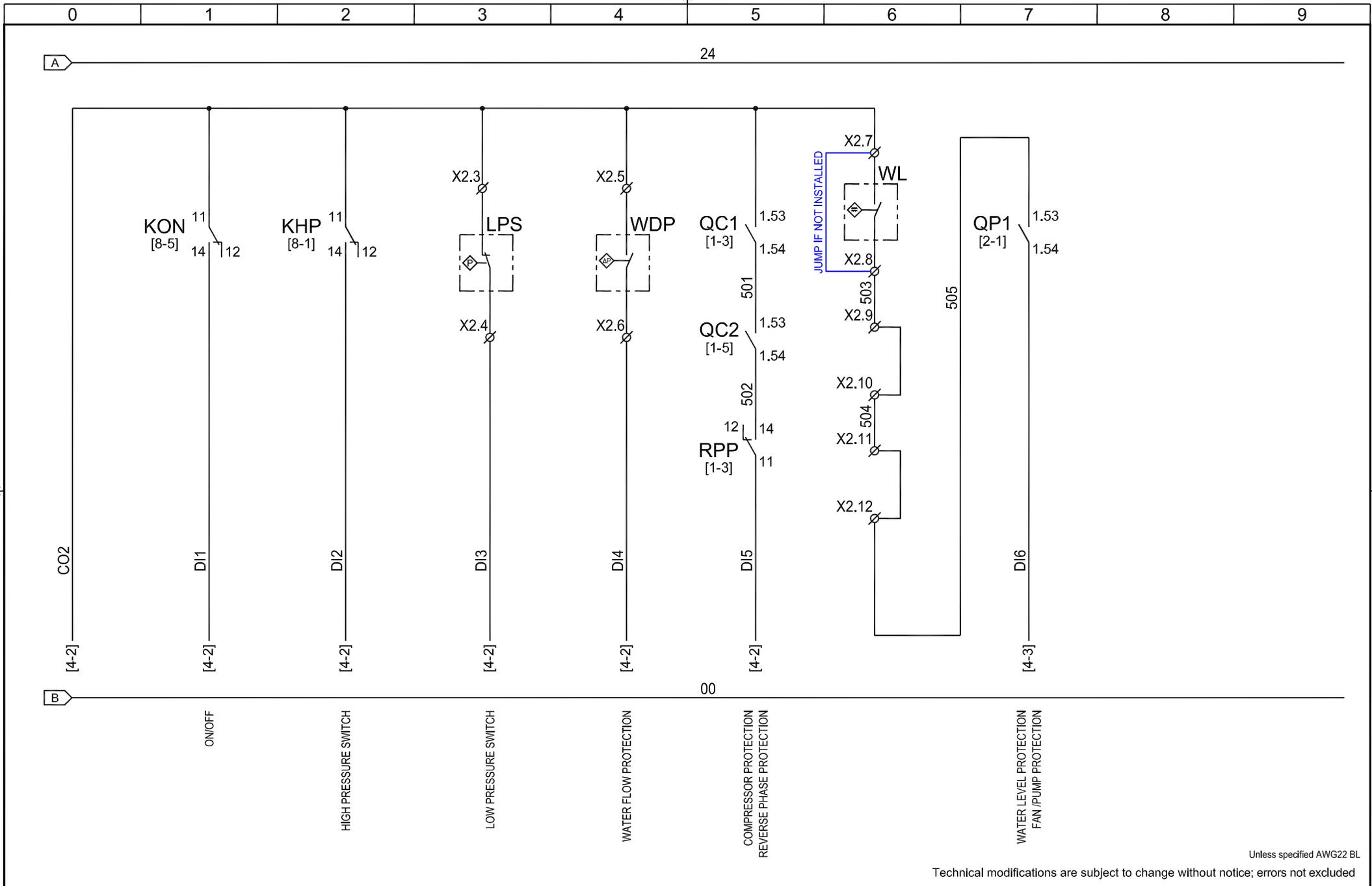

Unless specified AWG22 BL

Technical modifications are subject to change without notice; errors not excluded



Titolo / Title :

SCHEMA ELETTRICO CWU038+040
ELECTRICAL DIAGRAM CWU038+040

FRIULAIR S.r.l. - 33050 CERVIGNANO DEL FRIULI (UD) - ITALY - Via Cisis, 36

Drawing no. : **FRCWU90CWU040R0000**

Rev. **00**

Note :

-

Sheet **5** of **10**

COMPUTER AIDED DESIGN

This drawing cannot be reproduced, copied or given to third parties without FRIULAIR's written authorization

Questo disegno non può essere copiato, riprodotto né ceduto a terzi senza autorizzazione scritta della FRIULAIR S.r.l.

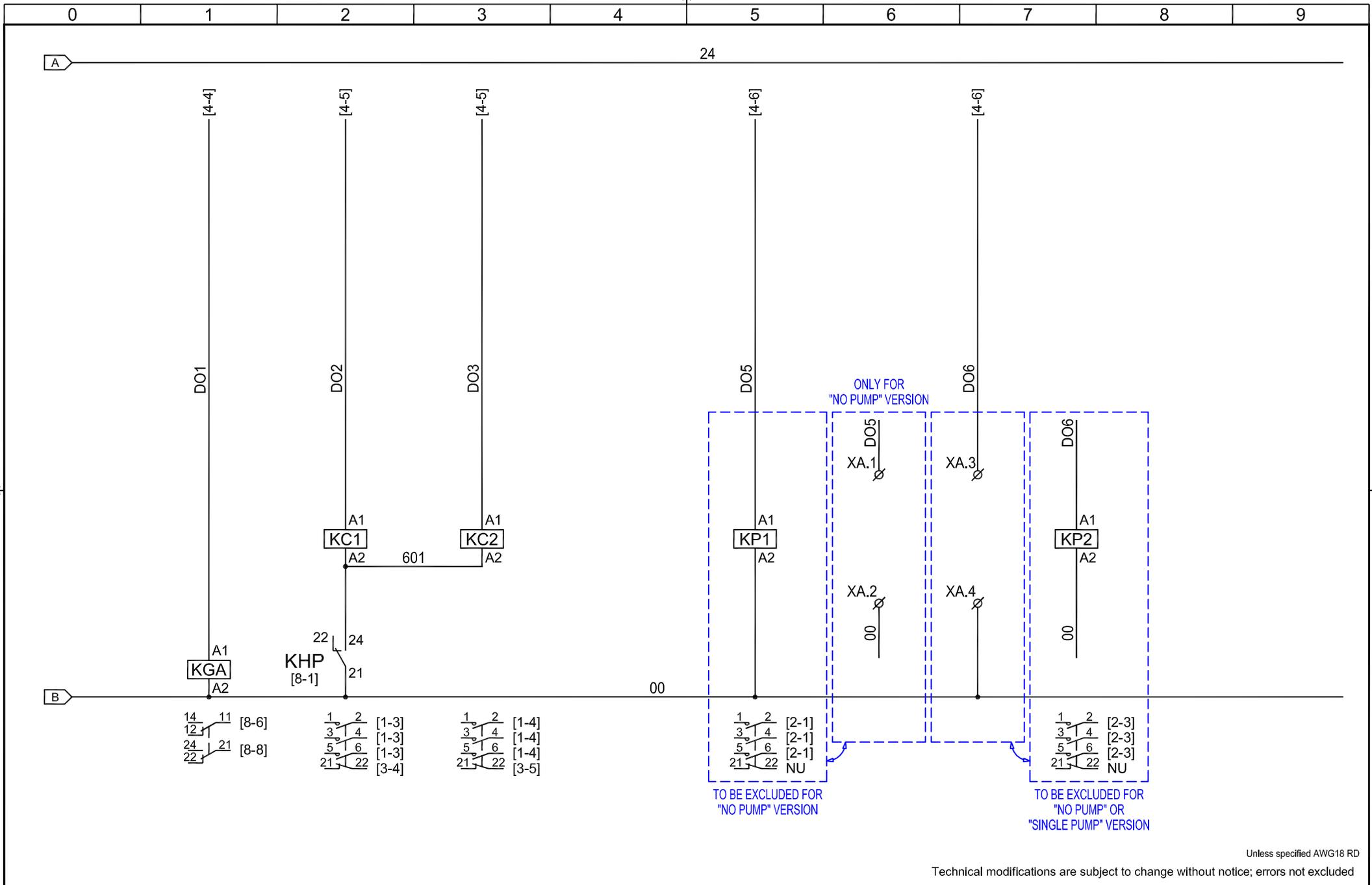

ONLY FOR "NO PUMP" VERSION

TO BE EXCLUDED FOR "NO PUMP" VERSION

TO BE EXCLUDED FOR "NO PUMP" OR "SINGLE PUMP" VERSION

Unless specified AWG18 RD

Technical modifications are subject to change without notice; errors not excluded



Titolo / Title : **SCHEMA ELETTRICO CWU038÷040**
ELECTRICAL DIAGRAM CWU038÷040
 FRIULAIR S.r.l. - 33050 CERVIGNANO DEL FRIULI (UD) - ITALY - Via Cisis, 36

Drawing no. : **FRCWU90CWU040R0000** Rev. **00**
 Note :
 - Sheet **6** of **10**

This drawing cannot be reproduced, copied or given to third parties without FRIULAIR's written authorization

Questo disegno non può essere copiato, riprodotto né ceduto a terzi senza autorizzazione scritta della FRIULAIR S.r.l.

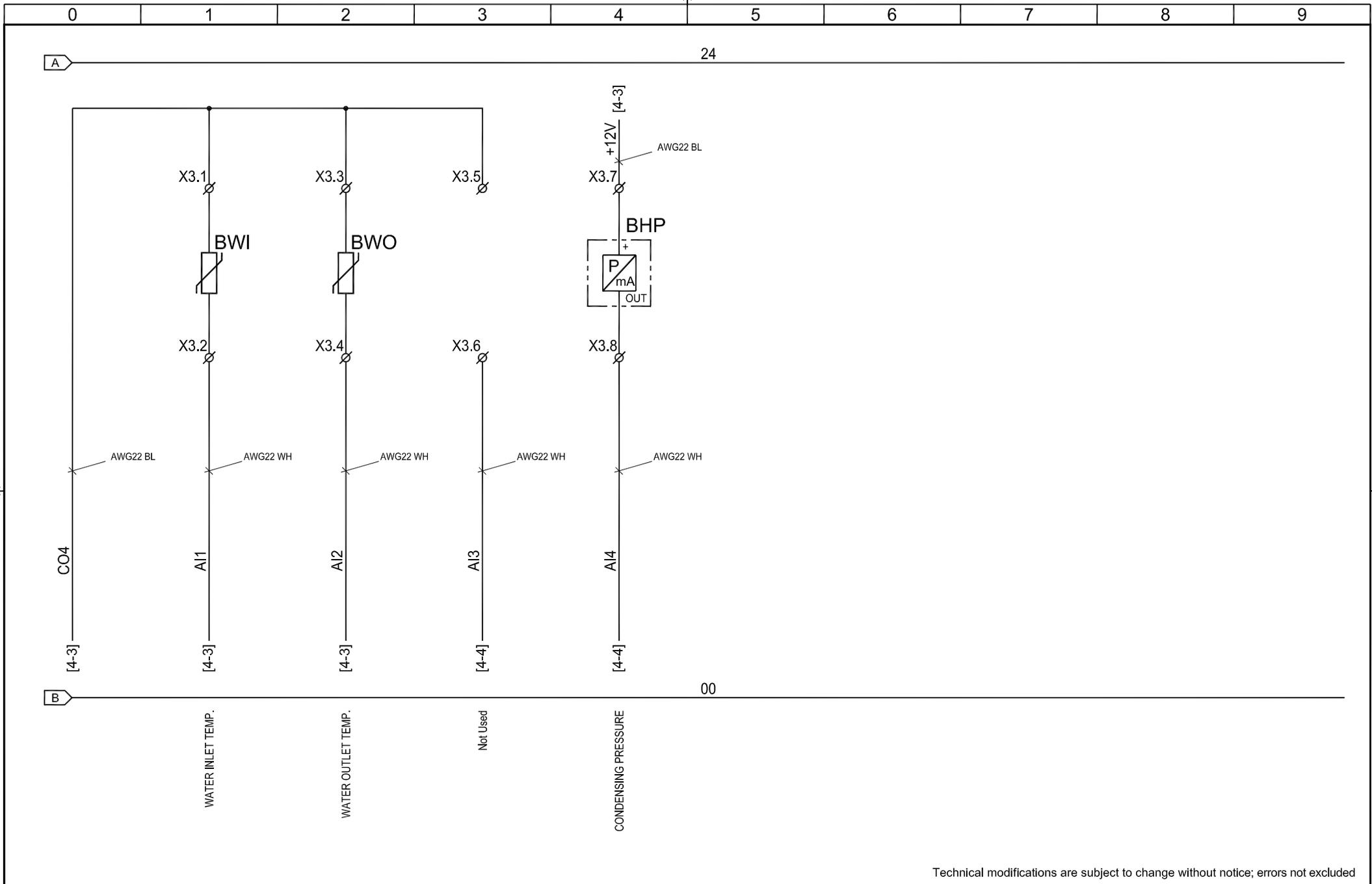

Technical modifications are subject to change without notice; errors not excluded



Titolo / Title :

SCHEMA ELETTRICO CWU038+040 ELECTRICAL DIAGRAM CWU038+040

FRIULAIR S.r.l. - 33050 CERVIGNANO DEL FRIULI (UD) - ITALY - Via Cisis, 36

Drawing no. :
FRCWU90CWU040R0000

Rev.
00

Note :

-

Sheet **7** of **10**

This drawing cannot be reproduced, copied or given to third parties without FRIULAIR's written authorization

Questo disegno non può essere copiato, riprodotto né ceduto a terzi senza autorizzazione scritta della FRIULAIR S.r.l.

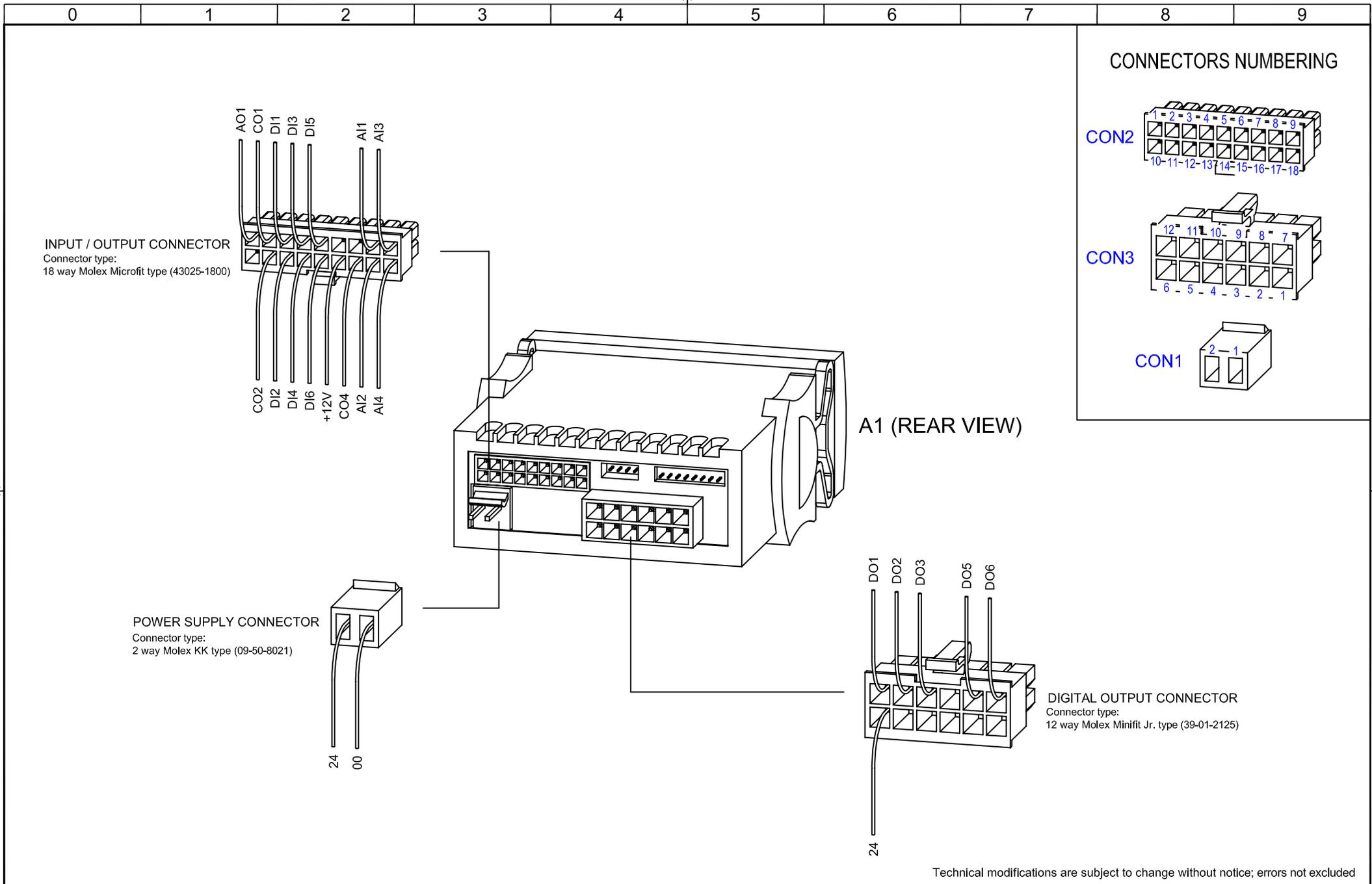

Technical modifications are subject to change without notice; errors not excluded



Titolo / Title : **SCHEMA ELETTRICO CWU038+040**
ELECTRICAL DIAGRAM CWU038+040

FRIULAIR S.r.l. - 33050 CERVIGNANO DEL FRIULI (UD) - ITALY - Via Cisis, 36

Drawing no. : **FRCWU90CWU040R0000** Rev. **00**

Note : -

Sheet **10** of **10**

COMPUTER AIDED DESIGN

This drawing cannot be reproduced, copied or given to
third parties without FRIULAIR's written authorization

Questo disegno non può essere copiato, riprodotto né ceduto
a terzi senza autorizzazione scritta della FRIULAIR S.r.l.

Titolo - Title

SCHEMA ELETTRICO CWU045÷065
ELECTRICAL DIAGRAM CWU045÷065

Disegno n° - Drawing nr.

FRCWU90CWU065R0000

Revisione - Revision

02

FRIULAIR
Dryers

FRIULAIR S.r.l. - 33050 CERVIGNANO DEL FRIULI (UD) - ITALY - Via Cisis, 36

This drawing cannot be reproduced, copied or given to third parties without FRIULAIR's written authorization

Questo disegno non può essere copiato, riprodotto né ceduto a terzi senza autorizzazione scritta della FRIULAIR S.r.l.

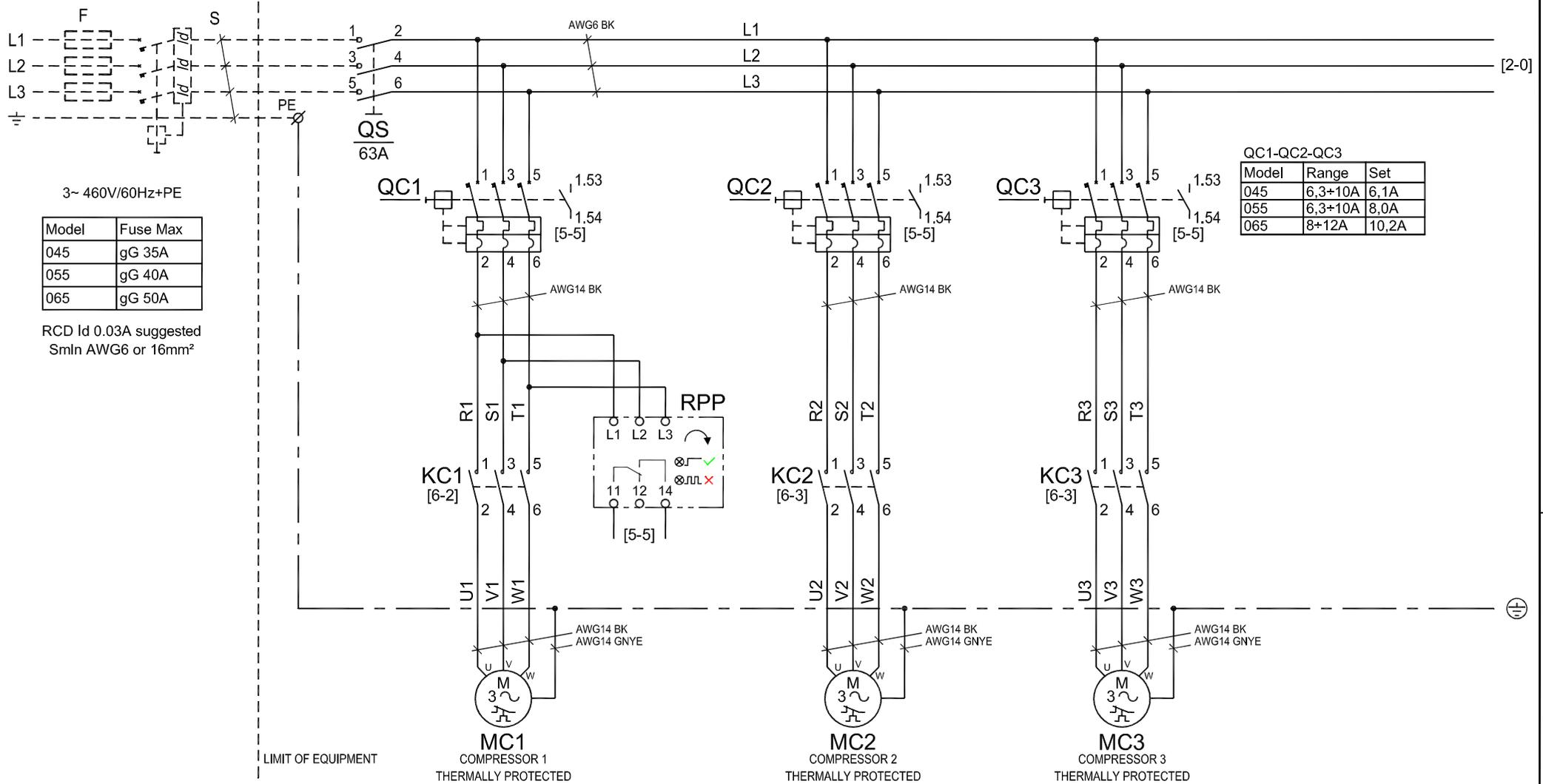

Technical modifications are subject to change without notice; errors not excluded

FRIULAIR
Dryers

Titolo / Title :

SCHEMA ELETTRICO CWU045+065
ELECTRICAL DIAGRAM CWU045+065

FRIULAIR S.r.l. - 33050 CERVIGNANO DEL FRIULI (UD) - ITALY - Via Cisis, 36

Drawing no. :

FRCWU90CWU065R0000

Rev.

01

Note :

-

Sheet 1 of 10

COMPUTER AIDED DESIGN

This drawing cannot be reproduced, copied or given to third parties without FRIULAIR's written authorization

Questo disegno non può essere copiato, riprodotto né ceduto a terzi senza autorizzazione scritta della FRIULAIR S.r.l.

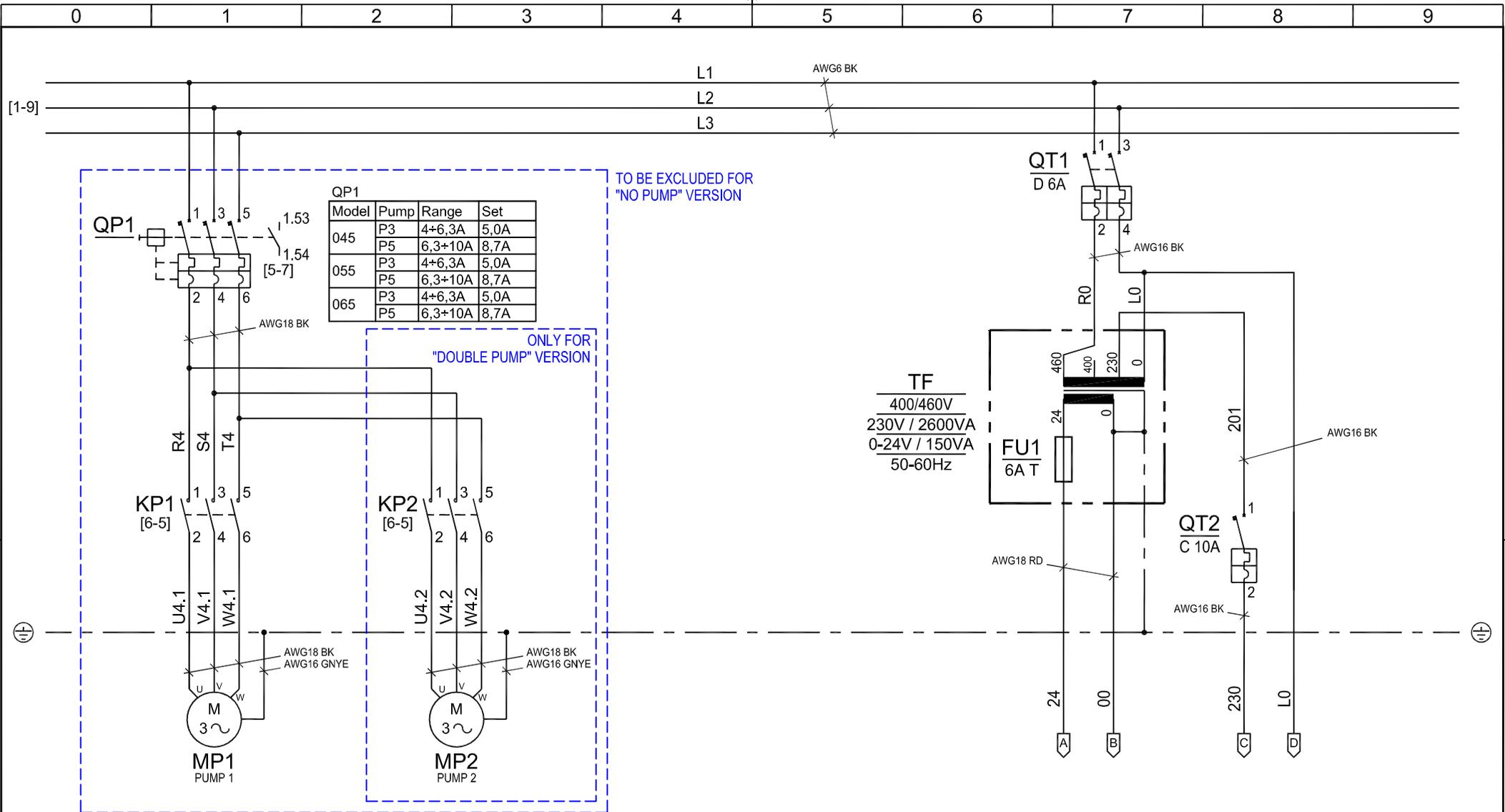

Technical modifications are subject to change without notice; errors not excluded



Titolo / Title :

SCHEMA ELETTRICO CWU045+065 ELECTRICAL DIAGRAM CWU045+065

FRIULAIR S.r.l. - 33050 CERVIGNANO DEL FRIULI (UD) - ITALY - Via Cisis, 36

Drawing no. :
FRCWU90CWU065R0000

Rev.
01

Note :

-

Sheet 2 of 10

COMPUTER AIDED DESIGN

This drawing cannot be reproduced, copied or given to third parties without FRIULAIR's written authorization

Questo disegno non può essere copiato, riprodotto né ceduto a terzi senza autorizzazione scritta della FRIULAIR S.r.l.

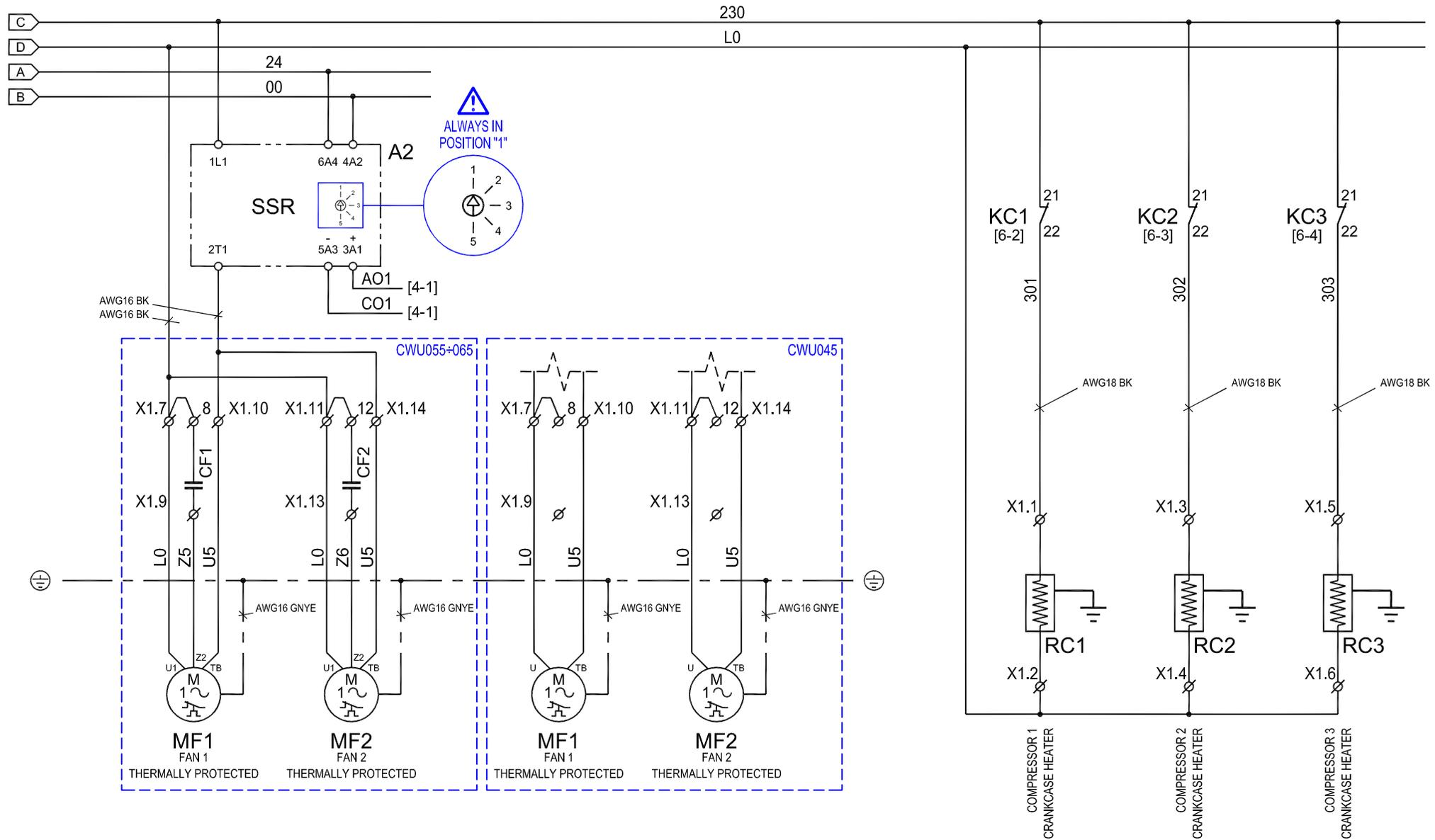

Unless specified AWG18 RD
 Technical modifications are subject to change without notice; errors not excluded



Titolo / Title :

SCHEMA ELETTRICO CWU045+065 ELECTRICAL DIAGRAM CWU045+065

FRIULAIR S.r.l. - 33050 CERVIGNANO DEL FRIULI (UD) - ITALY - Via Cisis, 36

Drawing no. : FRCWU90CWU065R0000

Rev. 01

Note :

-

Sheet 3 of 10

COMPUTER AIDED DESIGN

This drawing cannot be reproduced, copied or given to third parties without FRIULAIR's written authorization

Questo disegno non può essere copiato, riprodotto né ceduto a terzi senza autorizzazione scritta della FRIULAIR S.r.l.

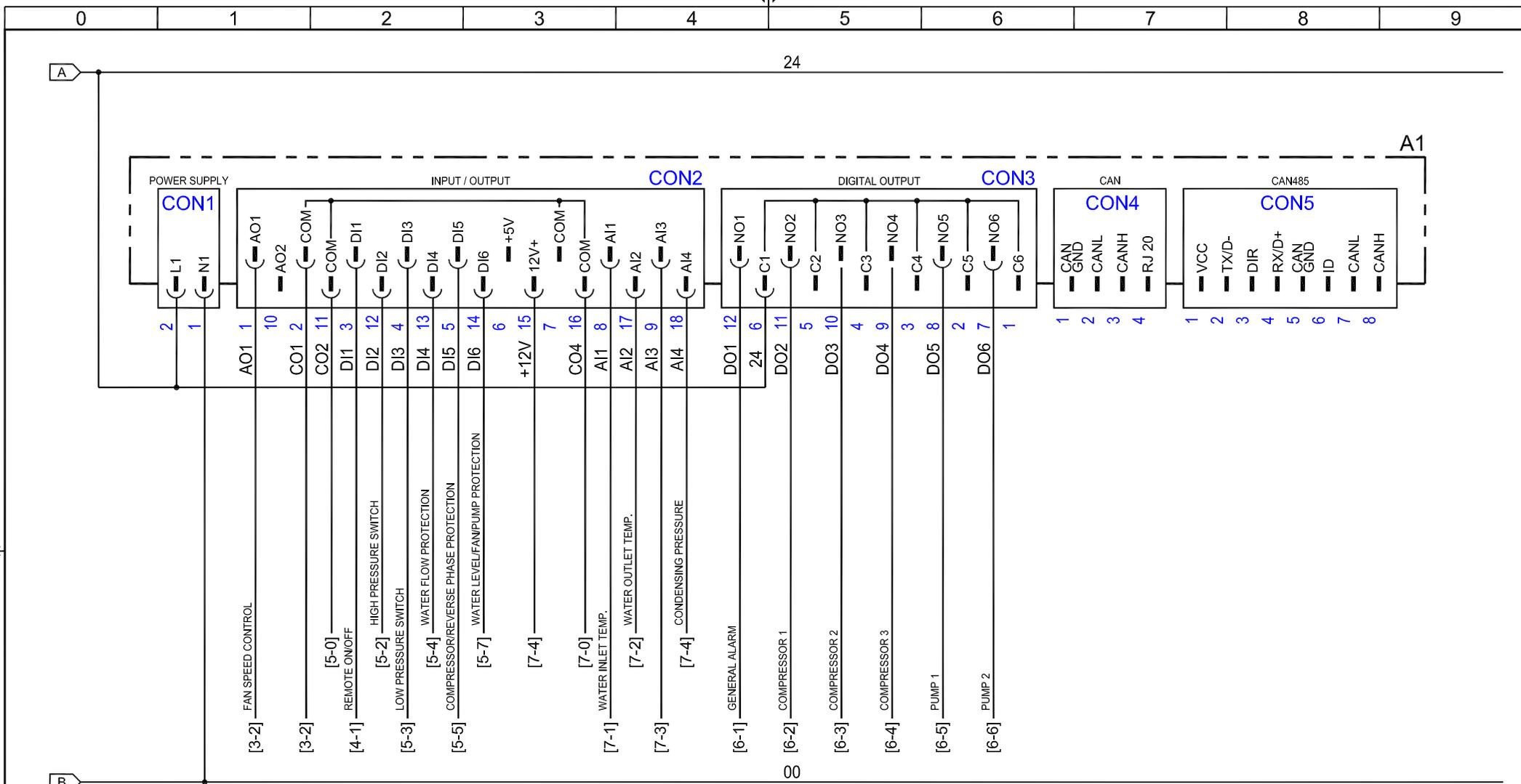

Technical modifications are subject to change without notice; errors not excluded



Titolo / Title :

SCHEMA ELETTRICO CWU045+065 ELECTRICAL DIAGRAM CWU045+065

FRIULAIR S.r.l. - 33050 CERVIGNANO DEL FRIULI (UD) - ITALY - Via Cisis, 36

Drawing no. : FRCWU90CWU065R0000

Rev. 01

Note :

-

Sheet 4 of 10

COMPUTER AIDED DESIGN

This drawing cannot be reproduced, copied or given to third parties without FRIULAIR's written authorization

Questo disegno non può essere copiato, riprodotto né ceduto a terzi senza autorizzazione scritta della FRIULAIR S.r.l.

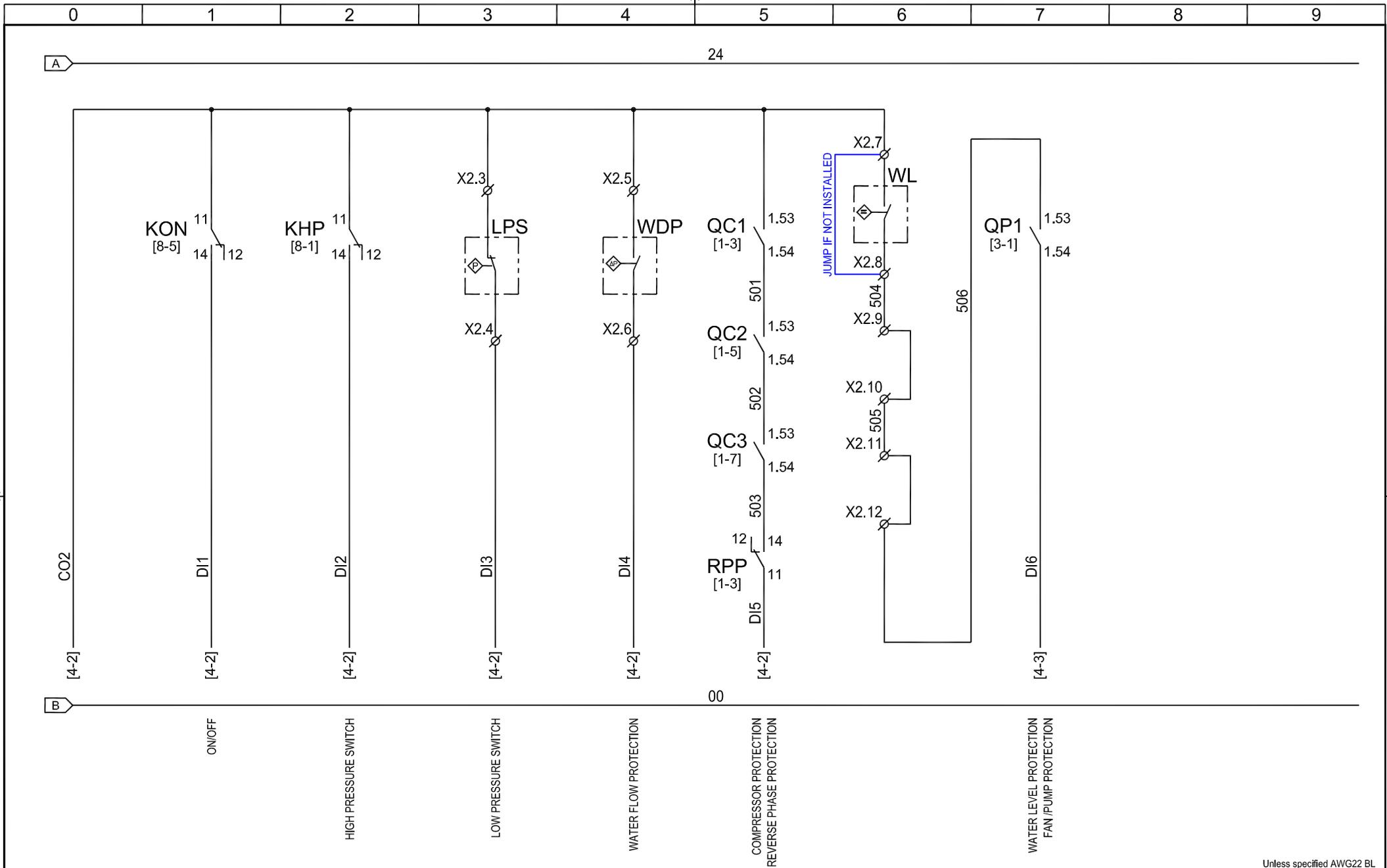

Unless specified AWG22 BL
 Technical modifications are subject to change without notice; errors not excluded



Titolo / Title : **SCHEMA ELETTRICO CWU045+065**
ELECTRICAL DIAGRAM CWU045+065
 FRIULAIR S.r.l. - 33050 CERVIGNANO DEL FRIULI (UD) - ITALY - Via Cisis, 36

Drawing no. : **FRCWU90CWU065R0000** Rev. **01**
 Note :
 - Sheet **5** of **10**

This drawing cannot be reproduced, copied or given to third parties without FRIULAIR's written authorization

Questo disegno non può essere copiato, riprodotto né ceduto a terzi senza autorizzazione scritta della FRIULAIR S.r.l.

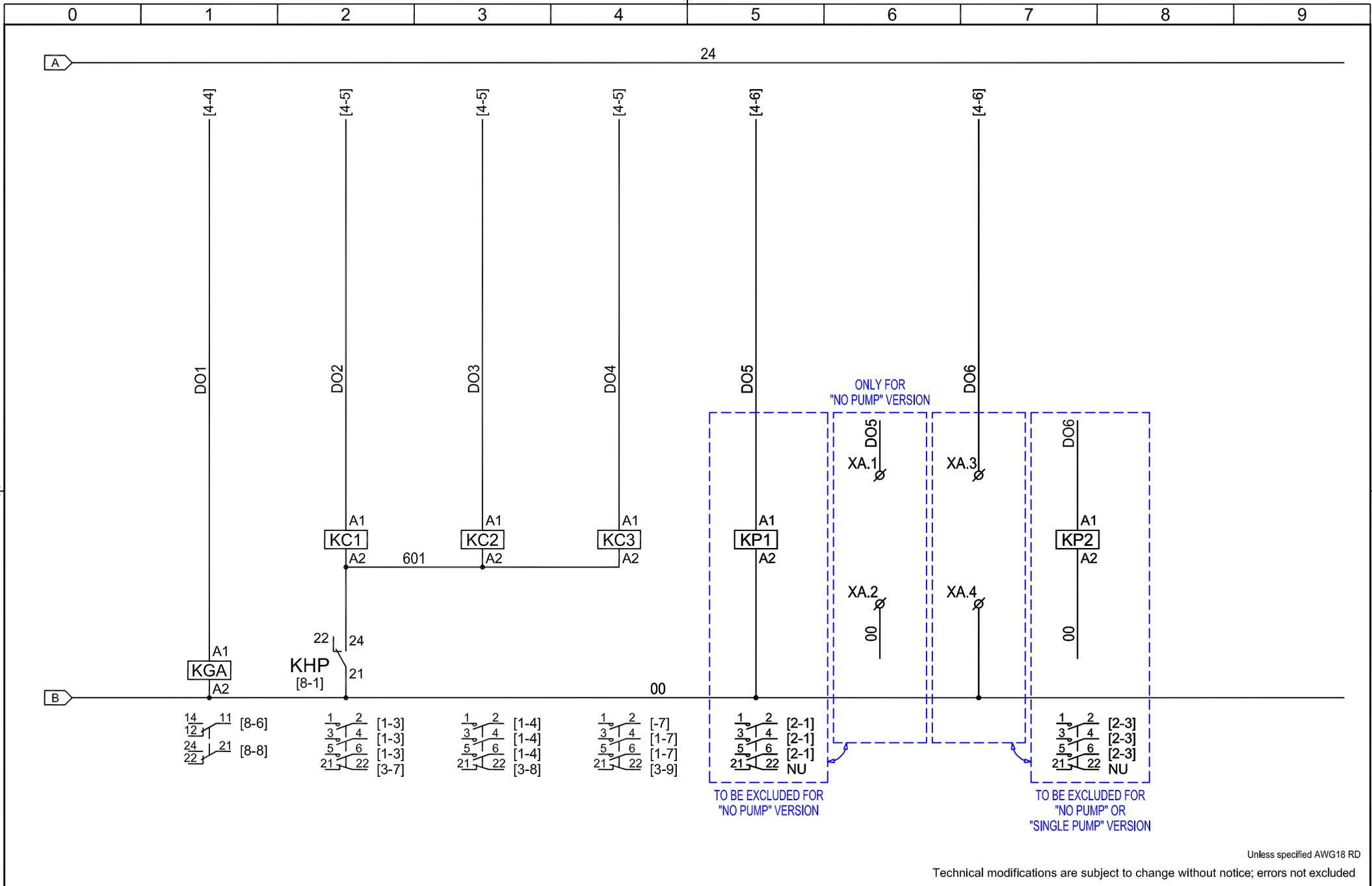

ONLY FOR "NO PUMP" VERSION

TO BE EXCLUDED FOR "NO PUMP" VERSION

TO BE EXCLUDED FOR "NO PUMP" OR "SINGLE PUMP" VERSION

Unless specified AWG18 RD

Technical modifications are subject to change without notice; errors not excluded



Titolo / Title :

SCHEMA ELETTRICO CWU045÷065
ELECTRICAL DIAGRAM CWU045÷065

FRIULAIR S.r.l. - 33050 CERVIGNANO DEL FRIULI (UD) - ITALY - Via Cisis, 36

Drawing no. : **FRCWU90CWU065R0000** Rev. **01**

Note :
 - Sheet **6** of **10**

This drawing cannot be reproduced, copied or given to third parties without FRIULAIR's written authorization

Questo disegno non può essere copiato, riprodotto né ceduto a terzi senza autorizzazione scritta della FRIULAIR S.r.l.

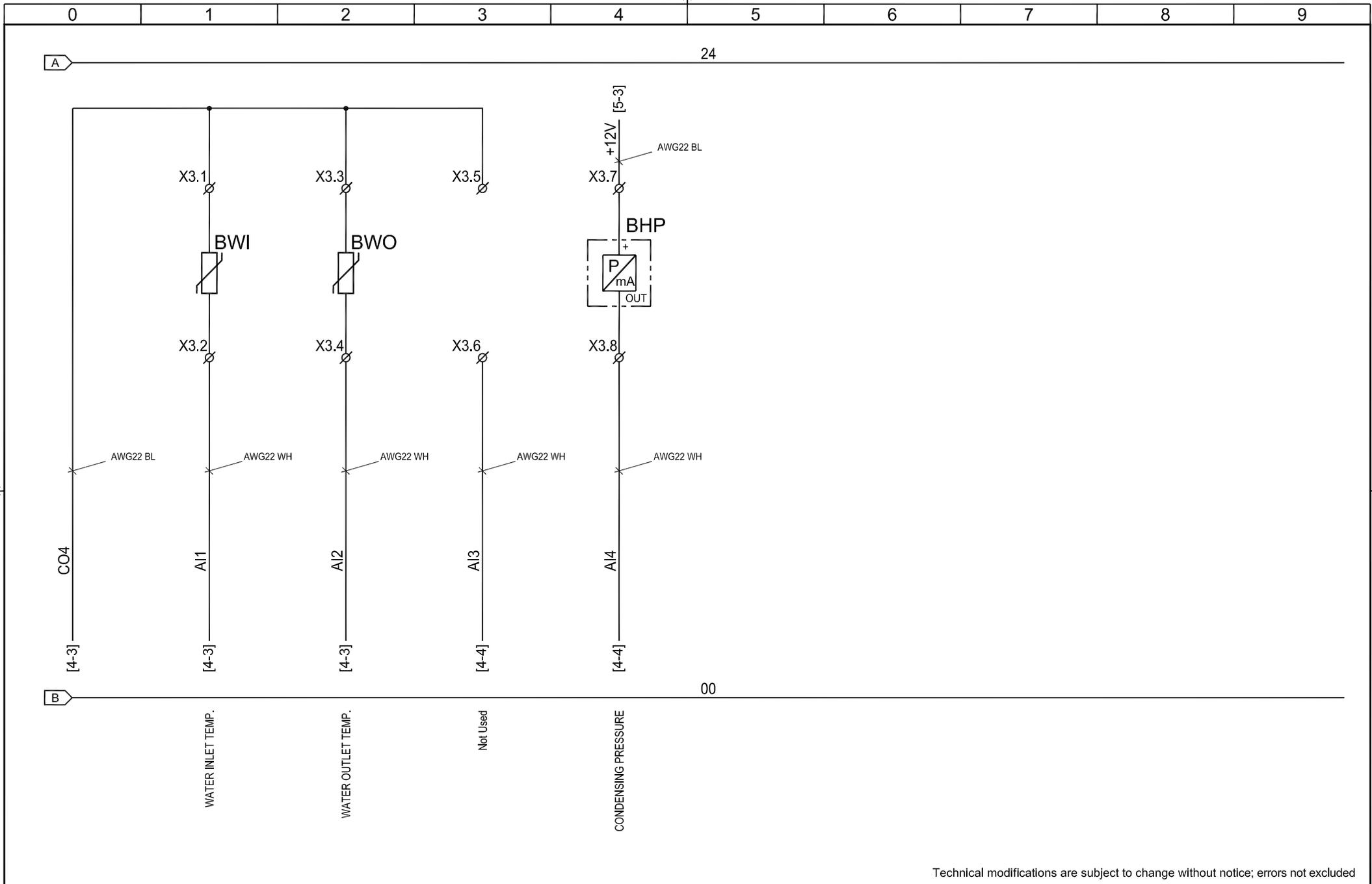

Technical modifications are subject to change without notice; errors not excluded



Titolo / Title :

SCHEMA ELETTRICO CWU045÷065 ELECTRICAL DIAGRAM CWU045÷065

FRIULAIR S.r.l. - 33050 CERVIGNANO DEL FRIULI (UD) - ITALY - Via Cisis, 36

Drawing no. : FRCWU90CWU065R0000

Rev. 01

Note :

-

Sheet 7 of 10

COMPUTER AIDED DESIGN

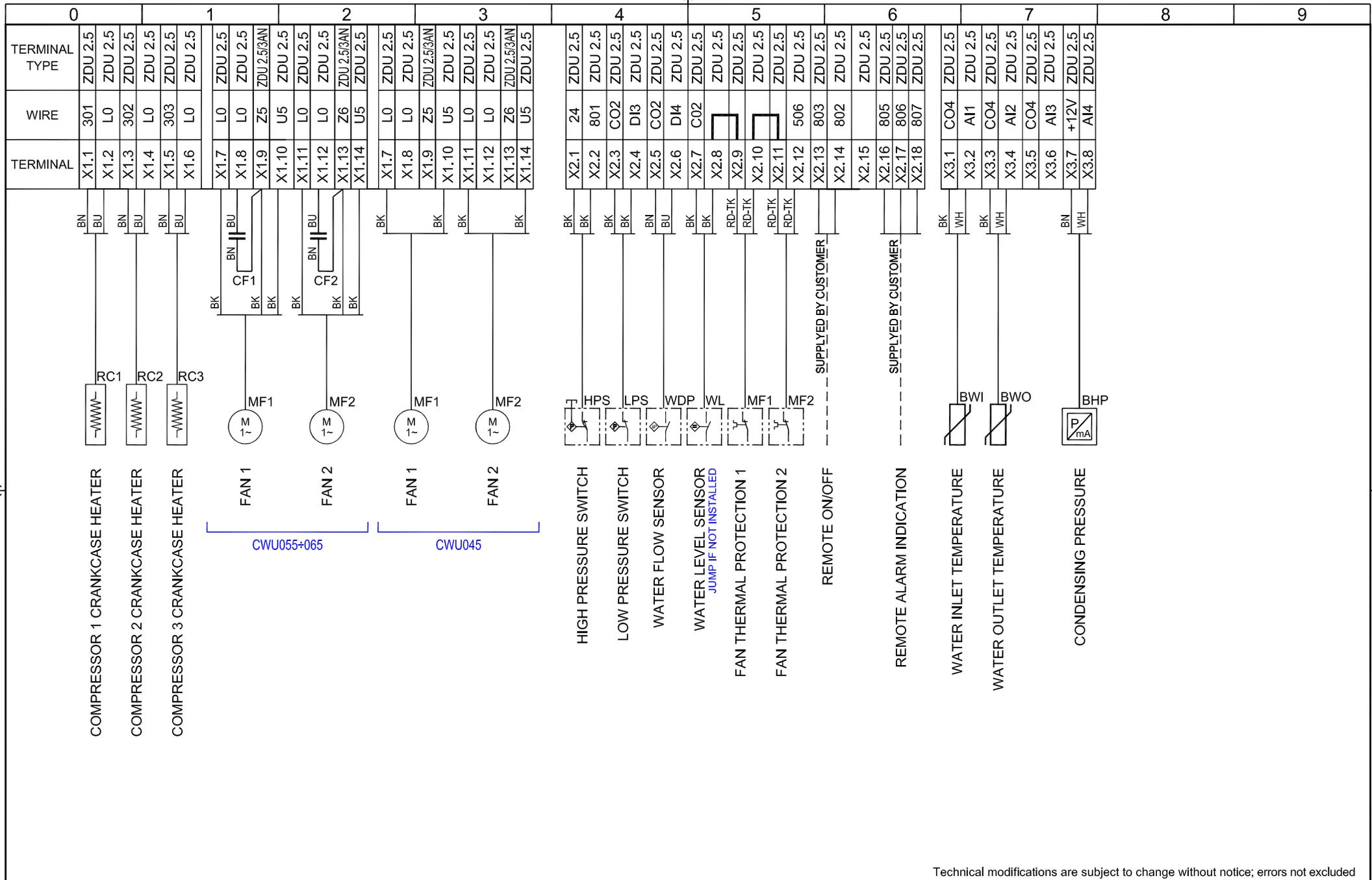

Technical modifications are subject to change without notice; errors not excluded



Titolo / Title :

SCHEMA ELETTRICO CWU045+065

ELECTRICAL DIAGRAM CWU045+065

FRIULAIR S.r.l. - 33050 CERVIGNANO DEL FRIULI (UD) - ITALY - Via Cisis, 36

Drawing no. : FRCWU90CWU065R0000 Rev. 01

Note : -

This drawing cannot be reproduced, copied or given to third parties without FRIULAIR's written authorization

Questo disegno non può essere copiato, riprodotto né ceduto a terzi senza autorizzazione scritta della FRIULAIR S.r.l.

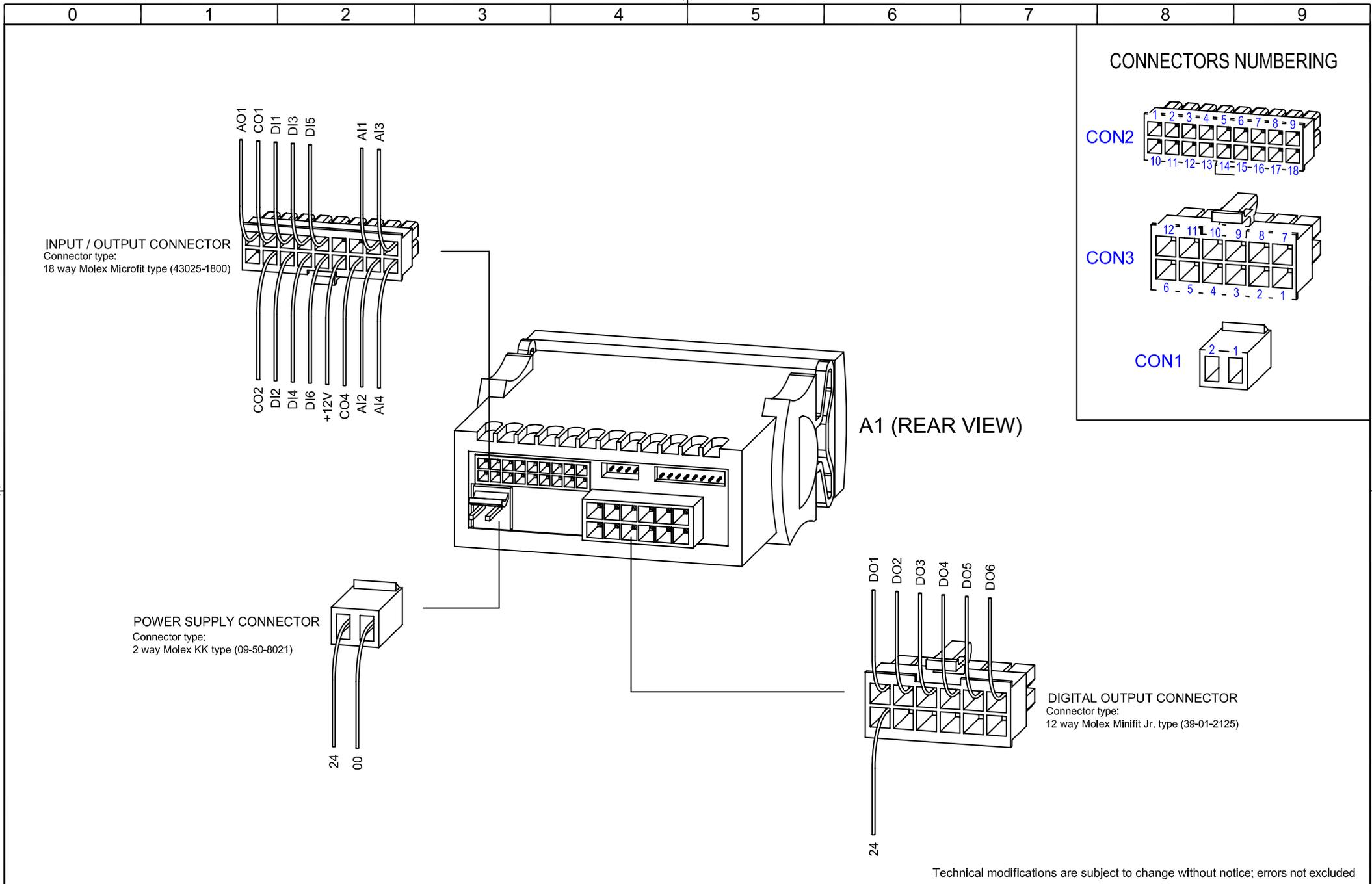

Technical modifications are subject to change without notice; errors not excluded



Titolo / Title : **SCHEMA ELETTRICO CWU045+065**
ELECTRICAL DIAGRAM CWU045+065

FRIULAIR S.r.l. - 33050 CERVIGNANO DEL FRIULI (UD) - ITALY - Via Cisis, 36

Drawing no. : **FRCWU90CWU065R0000** Rev. **01**

Note : -

Sheet **10** of **10**

This drawing cannot be reproduced, copied or given to third parties without FRIULAIR's written authorization

Questo disegno non può essere copiato, riprodotto né ceduto a terzi senza autorizzazione scritta della FRIULAIR S.r.l.

Titolo - Title

**SCHEMA ELETTRICO CWU075÷090
ELECTRICAL DIAGRAM CWU075÷090**

Disegno n° - Drawing nr.

FRCWU90CWU090R0000

Revisione - Revision

00

FRIULAIR
Dryers

FRIULAIR S.r.l. - 33050 CERVIGNANO DEL FRIULI (UD) - ITALY - Via Cisis, 36

This drawing cannot be reproduced, copied or given to third parties without FRIULAIR's written authorization

Questo disegno non può essere copiato, riprodotto né ceduto a terzi senza autorizzazione scritta della FRIULAIR S.r.l.

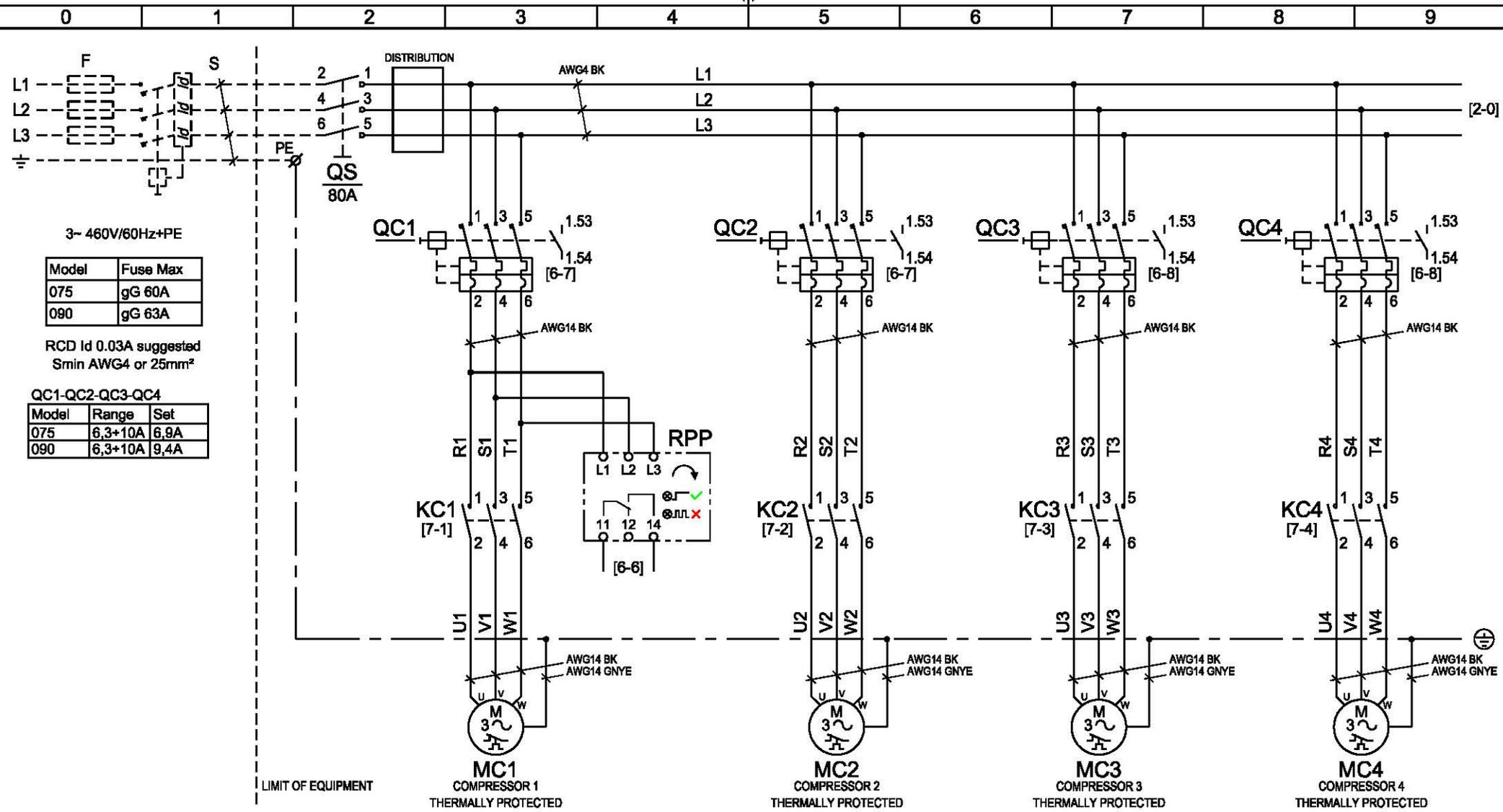

Technical modifications are subject to change without notice; errors not excluded



Titolo / Title : **SCHEMA ELETTRICO CWU075+090**
ELECTRICAL DIAGRAM CWU075+090

FRIULAIR S.r.l. - 33050 CERVIGNANO DEL FRIULI (UD) - ITALY - Via Cisis, 36

Drawing no. : **FRCWU90CWU090R0000** Rev. **00**

Note : -

Sheet **1** of **11**

This drawing cannot be reproduced, copied or given to third parties without FRIULAIR's written authorization

Questo disegno non può essere copiato, riprodotto né ceduto a terzi senza autorizzazione scritta della FRIULAIR S.r.l.

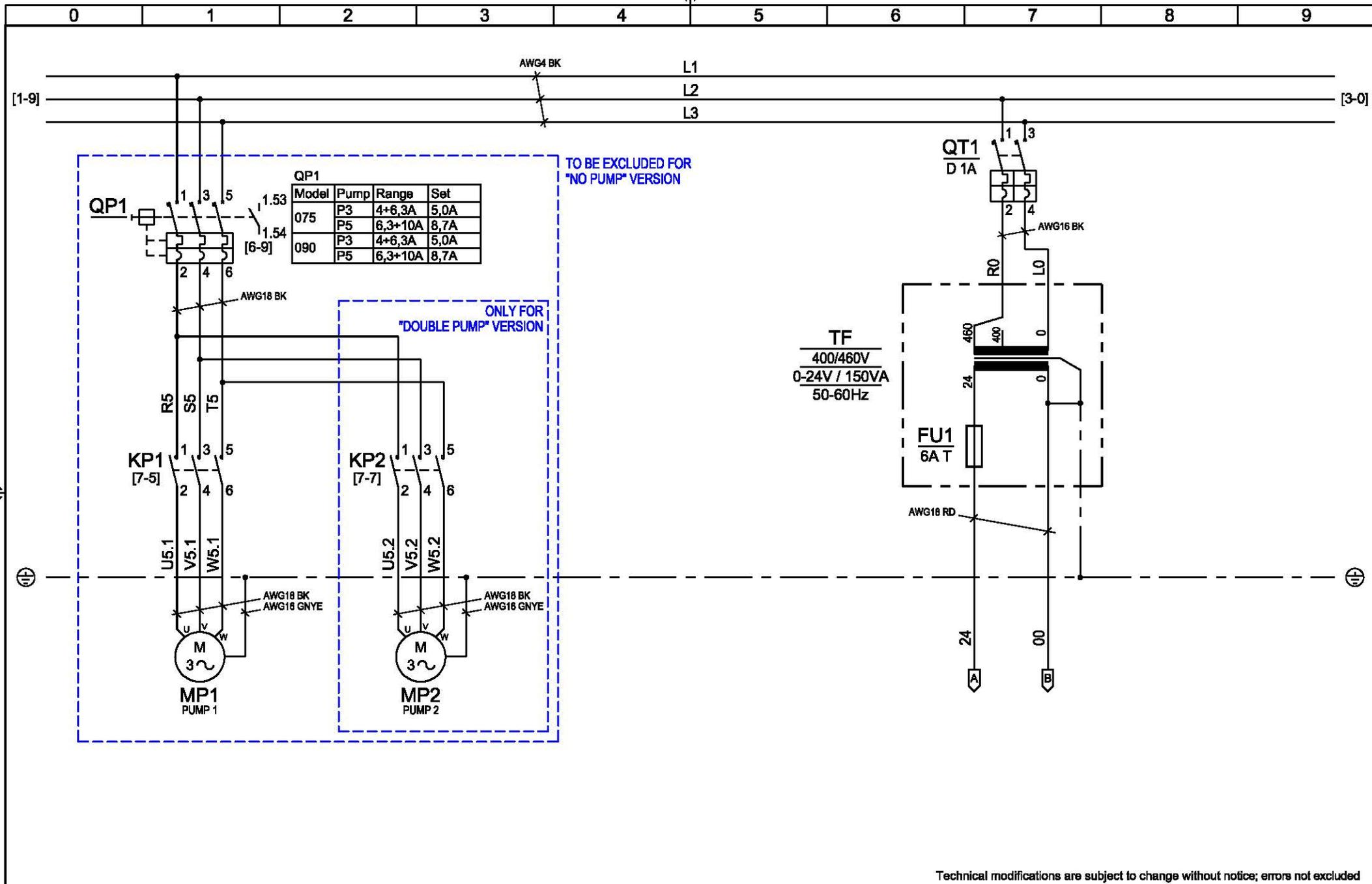

Technical modifications are subject to change without notice; errors not excluded



Titolo / Title : **SCHEMA ELETTRICO CWU075+090**
ELECTRICAL DIAGRAM CWU075+090
 FRIULAIR S.r.l. - 33050 CERVIGNANO DEL FRIULI (UD) - ITALY - Via Cisis, 36

Drawing no. : **FRCWU90CWU090R0000** Rev. **00**
 Note :
 -

This drawing cannot be reproduced, copied or given to third parties without FRIULAIR's written authorization

Questo disegno non può essere copiato, riprodotto né ceduto a terzi senza autorizzazione scritta della FRIULAIR S.r.l.

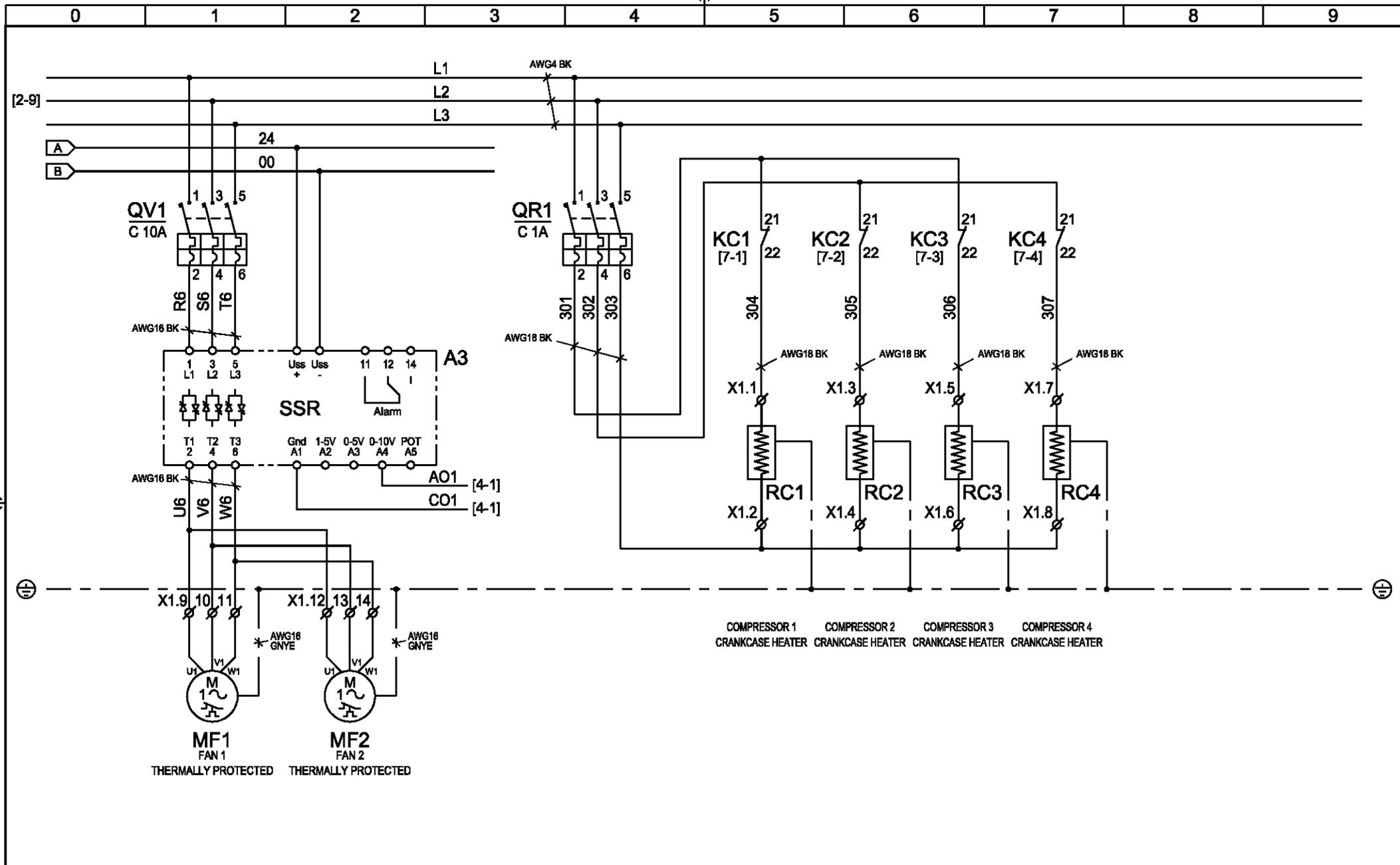

Unless specified AWG18 RD
 Technical modifications are subject to change without notice; errors not excluded



Titolo / Title : **SCHEMA ELETTRICO CWU075+090**
ELECTRICAL DIAGRAM CWU075+090
 FRIULAIR S.r.l. - 33050 CERVIGNANO DEL FRIULI (UD) - ITALY - Via Cisis, 36

Drawing no. : **FRCWU90CWU090R0000** Rev. **00**
 Note :
 -

Title / Title :

SCHEMA ELETRICO CWU075+090
ELECTRICAL DIAGRAM CWU075+090

FRIULAIR S.r.l. - 33050 CERVIGNANO DEL FRIULI (UD) - ITALY - Via Cisis, 36

Technical modifications are subject to change without notice; errors not excluded

Drawing no. : **FRCWU90CWU090R0000**
 Note :

Sheet 4 of 11

COMPUTER AIDED DESIGN

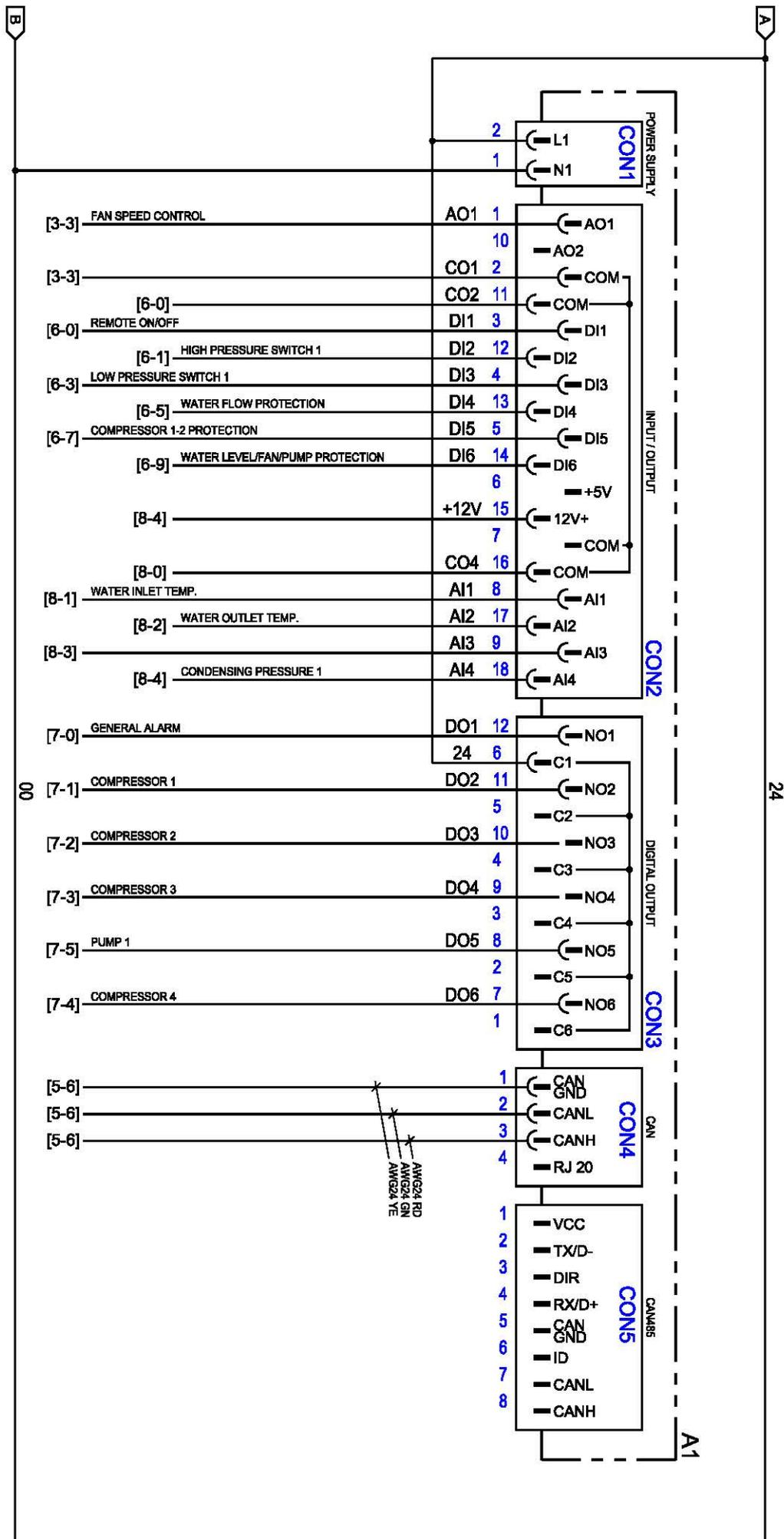

0 1 2 3 4 5 6 7 8 9

Title / Title :

**SCHEMA ELETRICO CWU075+090
ELECTRICAL DIAGRAM CWU075+090**

FRIULAIR S.r.l. - 33050 CERVIGNANO DEL FRIULI (UD) - ITALY - Via Cisis, 36

Technical modifications are subject to change without notice; errors not excluded

Drawing no. : **FRCWU90CWU090R0000**
Note :

Rev. **00**

Sheet **5** of **11**

COMPUTER AIDED DESIGN

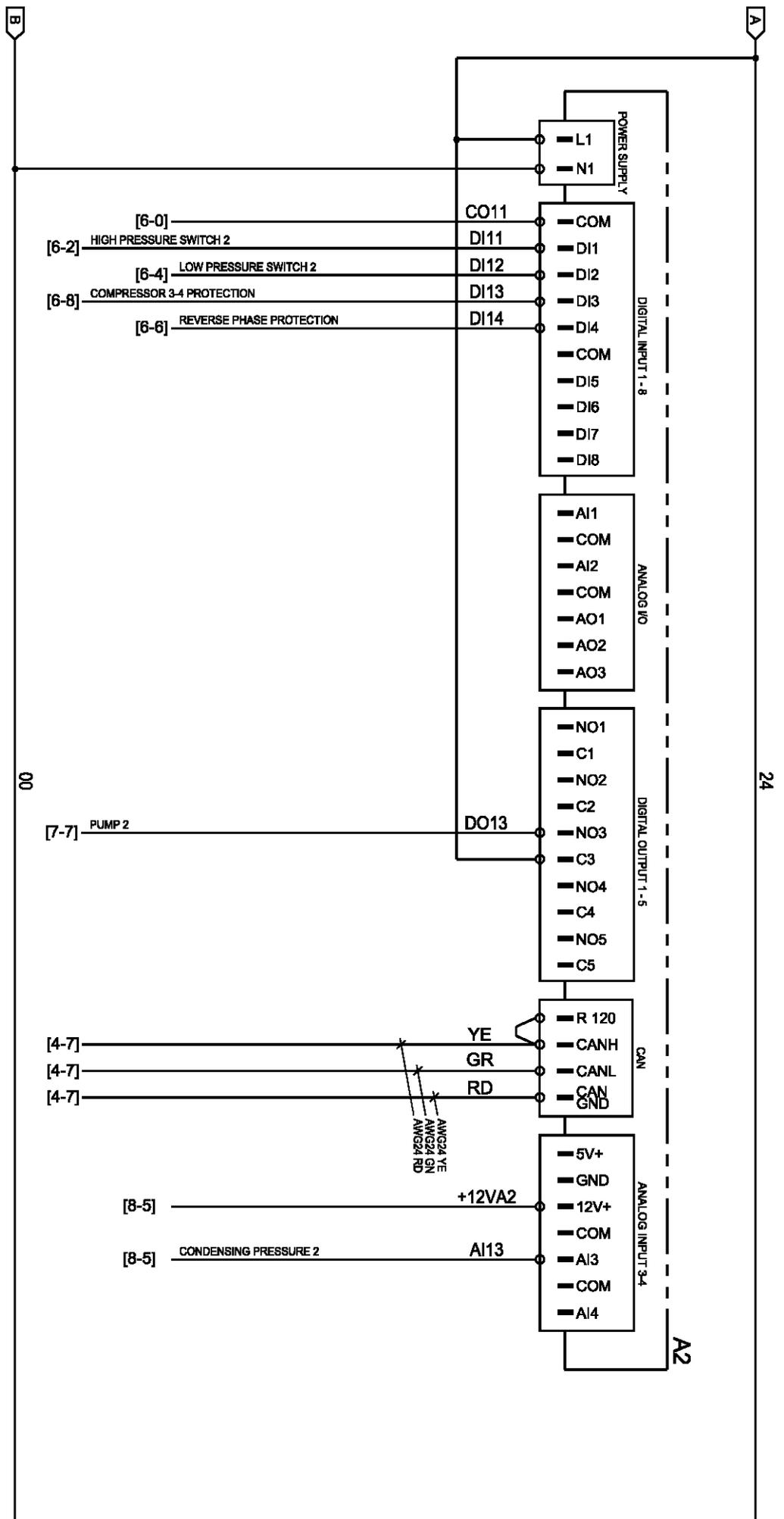

0 1 2 3 4 5 6 7 8 9

24

A2

This drawing cannot be reproduced, copied or given to third parties without FRIULAIR's written authorization

Questo disegno non può essere copiato, riprodotto né ceduto a terzi senza autorizzazione scritta della FRIULAIR S.r.l.

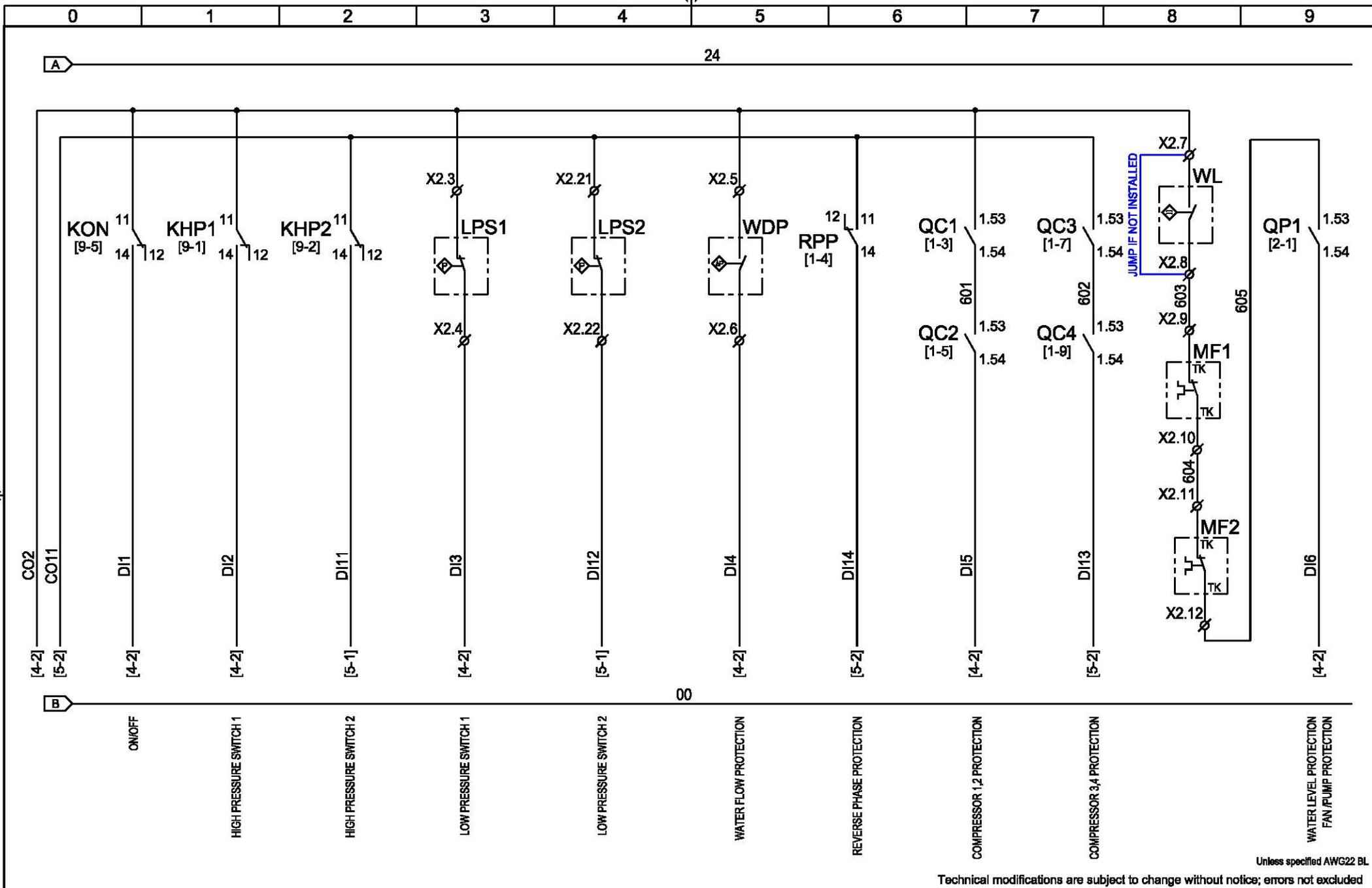

Unless specified AWG22 BL
 Technical modifications are subject to change without notice; errors not excluded



Titolo / Title : **SCHEMA ELETTRICO CWU075+090**
ELECTRICAL DIAGRAM CWU075+090
 FRIULAIR S.r.l. - 33050 CERVIGNANO DEL FRIULI (UD) - ITALY - Via Cisis, 36

Drawing no. : **FRCWU90CWU090R0000** Rev. **00**
 Note :
 - Sheet **6** of **11**
 COMPUTER AIDED DESIGN

This drawing cannot be reproduced, copied or given to third parties without FRIULAIR's written authorization

Questo disegno non può essere copiato, riprodotto né ceduto a terzi senza autorizzazione scritta della FRIULAIR S.r.l.

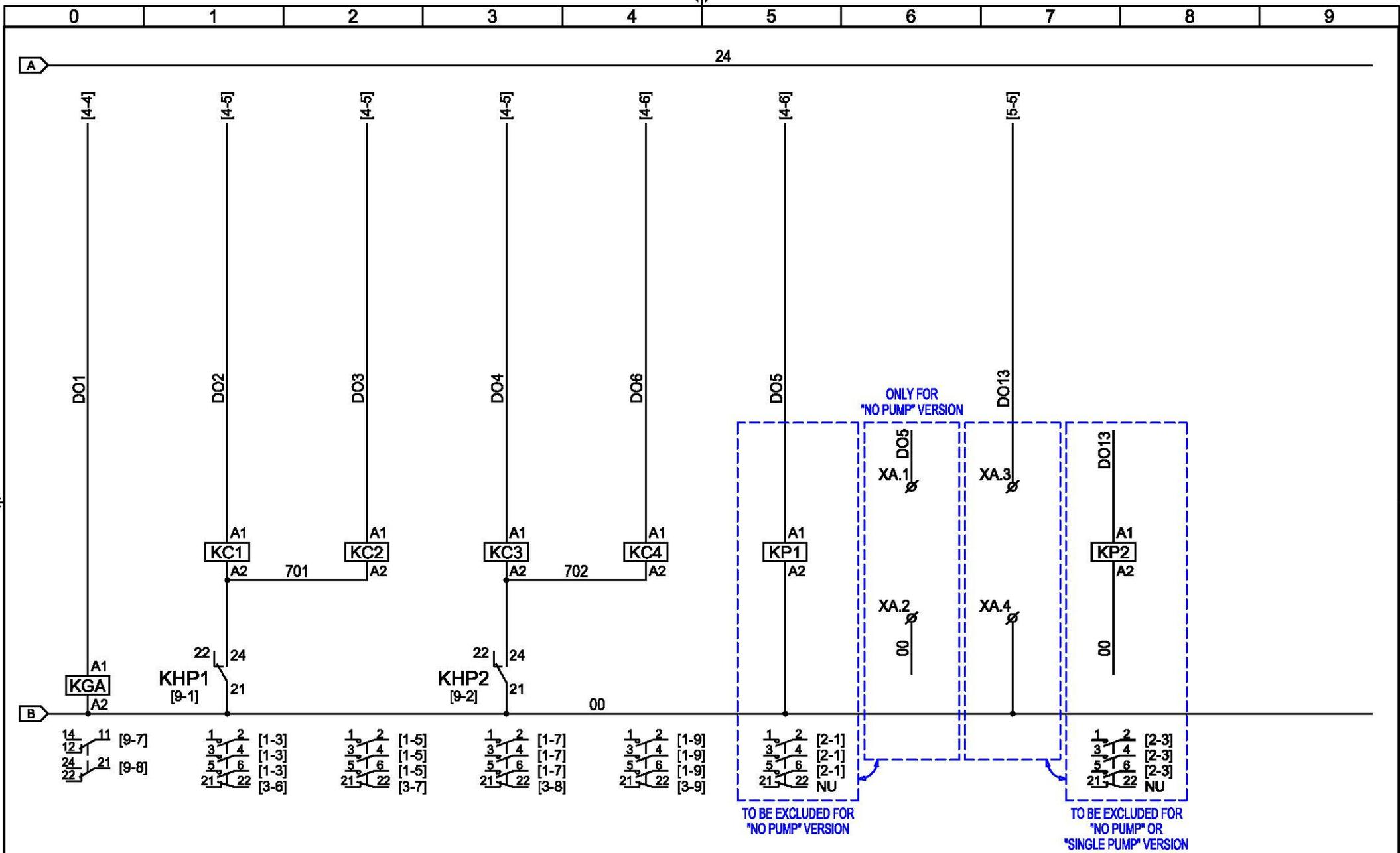

Unless specified AWG18 RD
 Technical modifications are subject to change without notice; errors not excluded



Titolo / Title : **SCHEMA ELETTRICO CWU075+090**
ELECTRICAL DIAGRAM CWU075+090
 FRIULAIR S.r.l. - 33050 CERVIGNANO DEL FRIULI (UD) - ITALY - Via Cisis, 36

Drawing no. : **FRCWU90CWU090R0000** Rev. **00**
 Note :
 -

This drawing cannot be reproduced, copied or given to third parties without FRIULAIR's written authorization

Questo disegno non può essere copiato, riprodotto né ceduto a terzi senza autorizzazione scritta della FRIULAIR S.r.l.

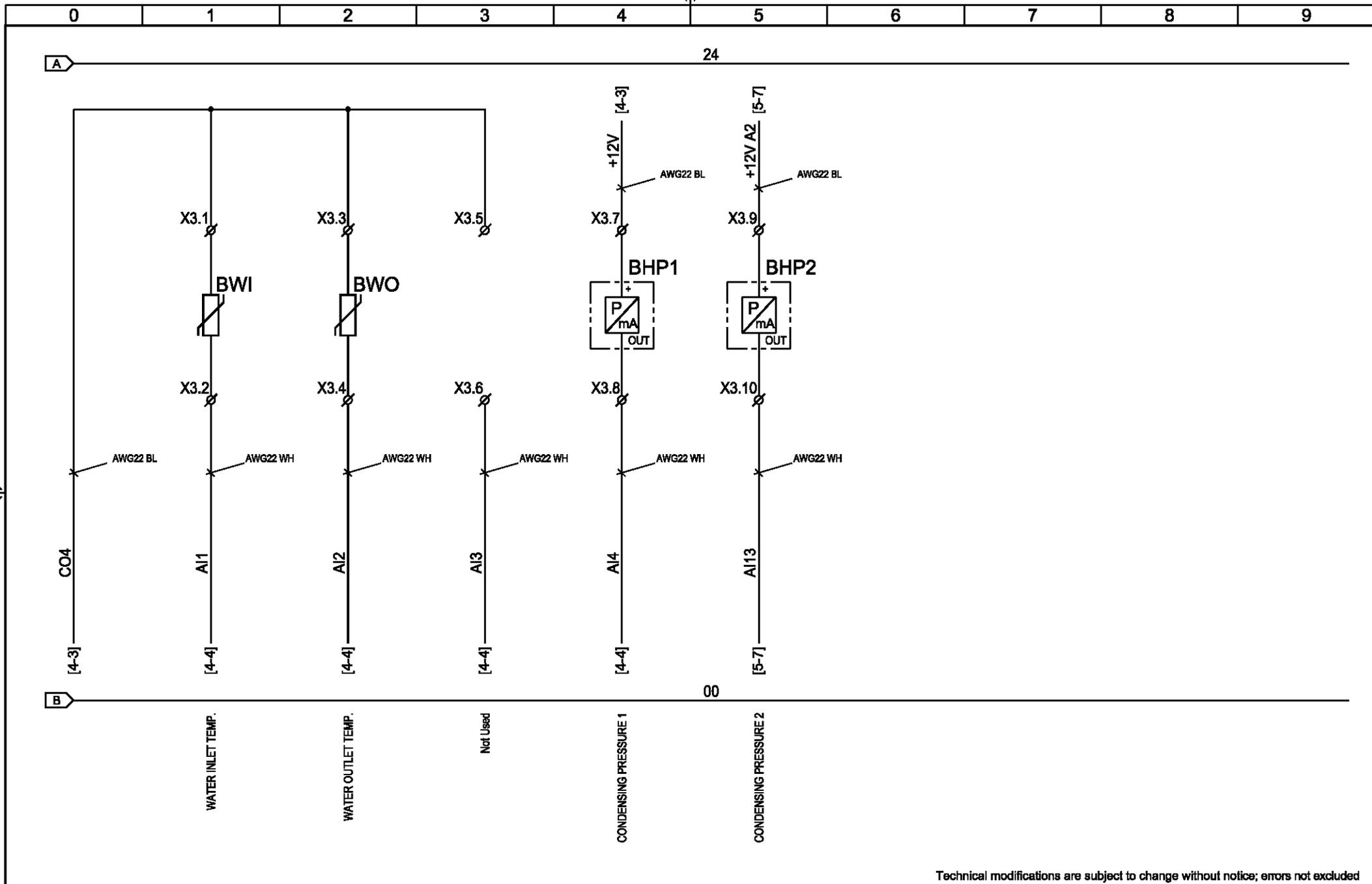

Technical modifications are subject to change without notice; errors not excluded



Titolo / Title : **SCHEMA ELETTRICO CWU075+090**
ELECTRICAL DIAGRAM CWU075+090
 FRIULAIR S.r.l. - 33050 CERVIGNANO DEL FRIULI (UD) - ITALY - Via Cisis, 36

Drawing no. : **FRCWU90CWU090R0000** Rev. **00**
 Note :
 -

This drawing cannot be reproduced, copied or given to third parties without FRIULAIR's written authorization

Questo disegno non può essere copiato, riprodotto né ceduto a terzi senza autorizzazione scritta della FRIULAIR S.r.l.

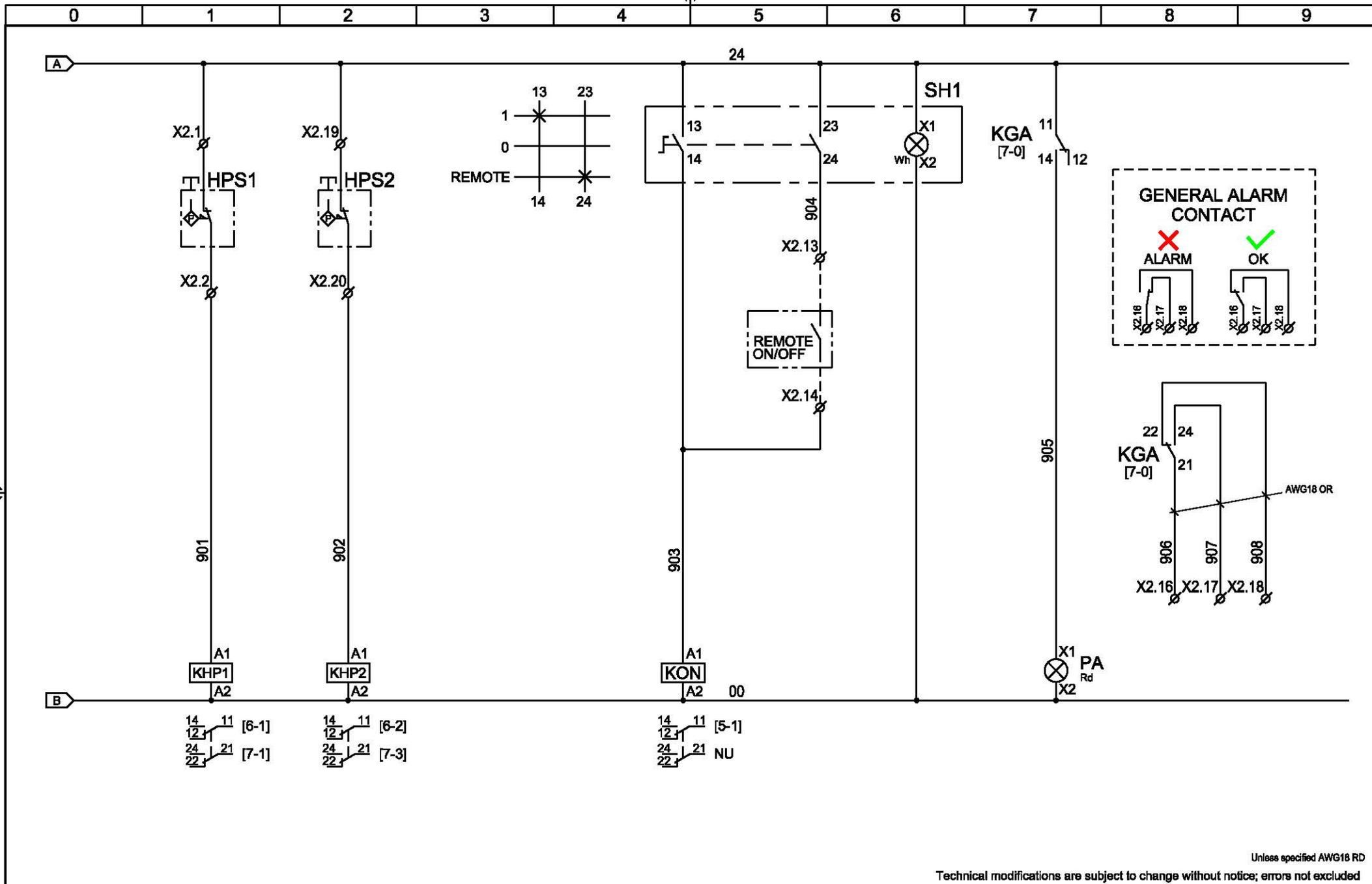

Unless specified AWG18 RD
 Technical modifications are subject to change without notice; errors not excluded



Titolo / Title : **SCHEMA ELETTRICO CWU075+090**
ELECTRICAL DIAGRAM CWU075+090
 FRIULAIR S.r.l. - 33050 CERVIGNANO DEL FRIULI (UD) - ITALY - Via Cisis, 36

Drawing no. : **FRCWU90CWU090R0000** Rev. **00**
 Note :
 - Sheet **9** of **11**

Title / Title :

**SCHEMA ELETRICO CWU075+090
ELECTRICAL DIAGRAM CWU075+090**

Drawing no. : **FRCWU90CWU090R0000**
Note :

Technical modifications are subject to change without notice; errors not excluded

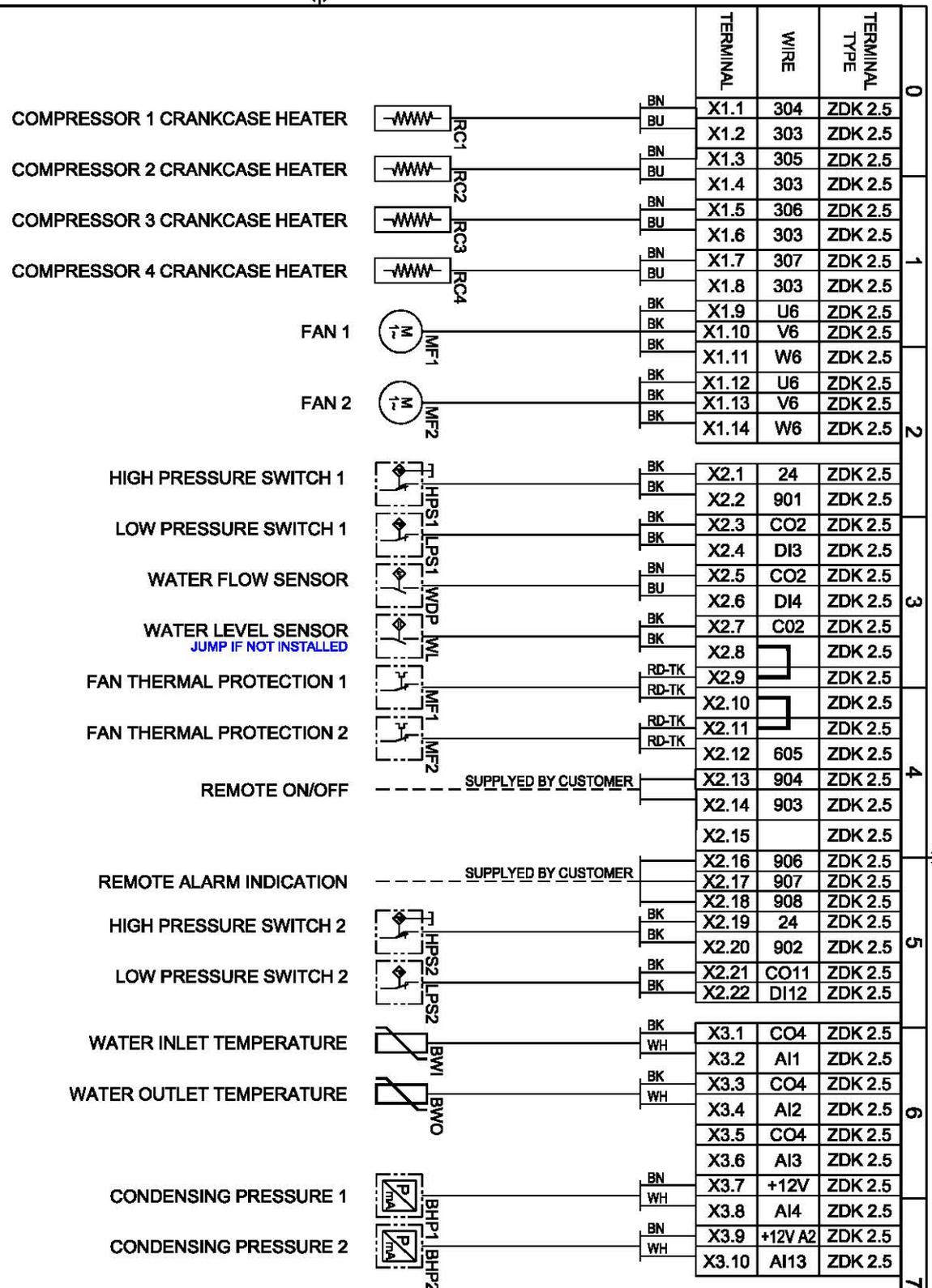

0
1
2
3
4
5
6
7
8
9

This drawing cannot be reproduced, copied or given to third parties without FRIULAIR's written authorization

Questo disegno non può essere copiato, riprodotto né ceduto a terzi senza autorizzazione scritta della FRIULAIR S.r.l.

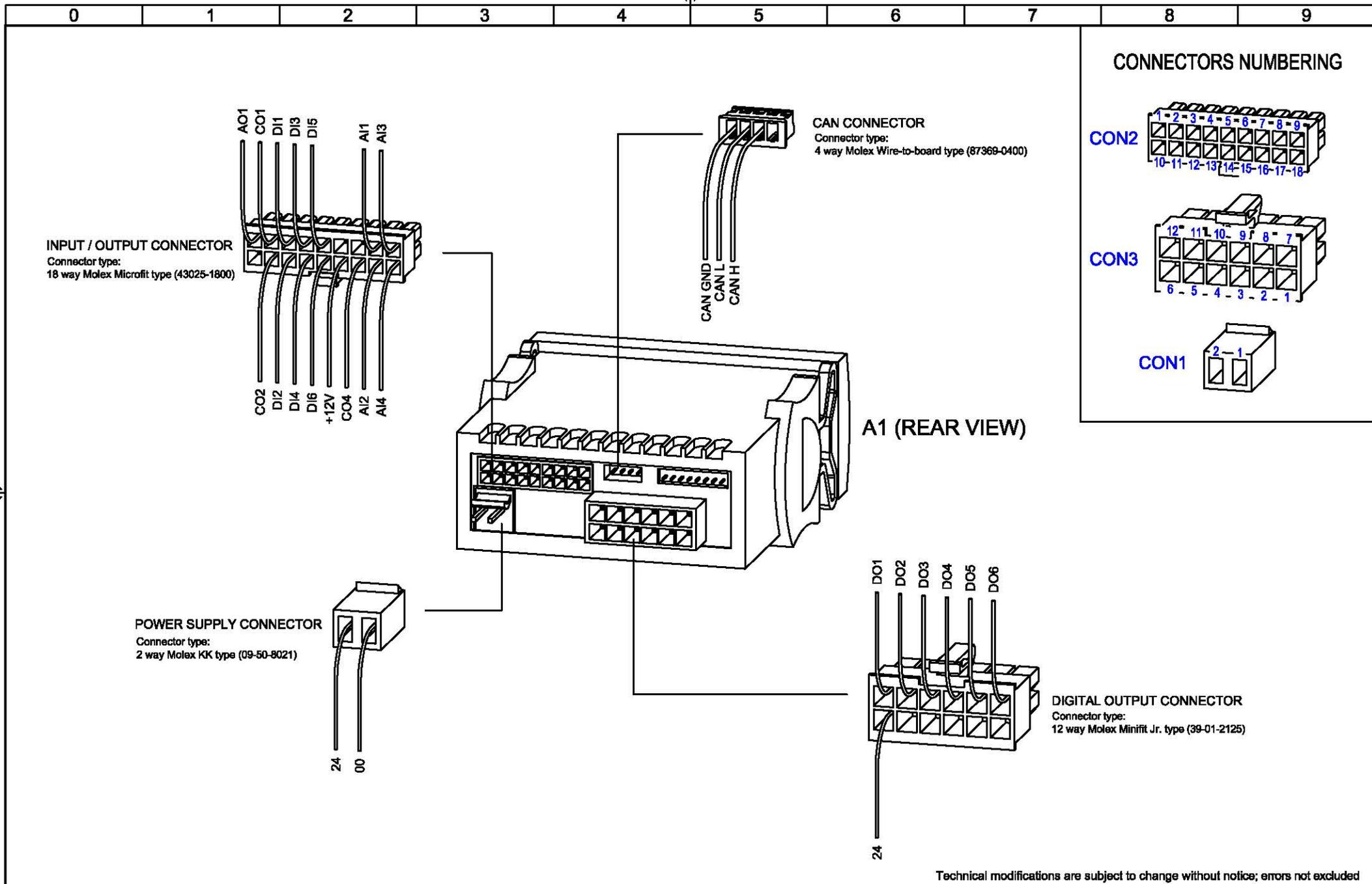

Technical modifications are subject to change without notice; errors not excluded



Titolo / Title : **SCHEMA ELETTRICO CWU075+090**
ELECTRICAL DIAGRAM CWU075+090

FRIULAIR S.r.l. - 33050 CERVIGNANO DEL FRIULI (UD) - ITALY - Via Cisis, 36

Drawing no. : **FRCWU90CWU090R0000** Rev. **00**

Note : -

Sheet **11** of **11**

This drawing cannot be reproduced, copied or given to
third parties without FRIULAIR's written authorization

Questo disegno non può essere copiato, riprodotto né ceduto
a terzi senza autorizzazione scritta della FRIULAIR S.r.l.

Titolo - Title

SCHEMA ELETTRICO CWU110 ELECTRICAL DIAGRAM CWU110

Disegno n° - Drawing nr.

FRCWU90CWU110R0000

Revisione - Revision

00

FRIULAIR
Dryers

FRIULAIR S.r.l. - 33050 CERVIGNANO DEL FRIULI (UD) - ITALY - Via Cisis, 36

This drawing cannot be reproduced, copied or given to third parties without FRIULAIR's written authorization

Questo disegno non può essere copiato, riprodotto né ceduto a terzi senza autorizzazione scritta della FRIULAIR S.r.l.

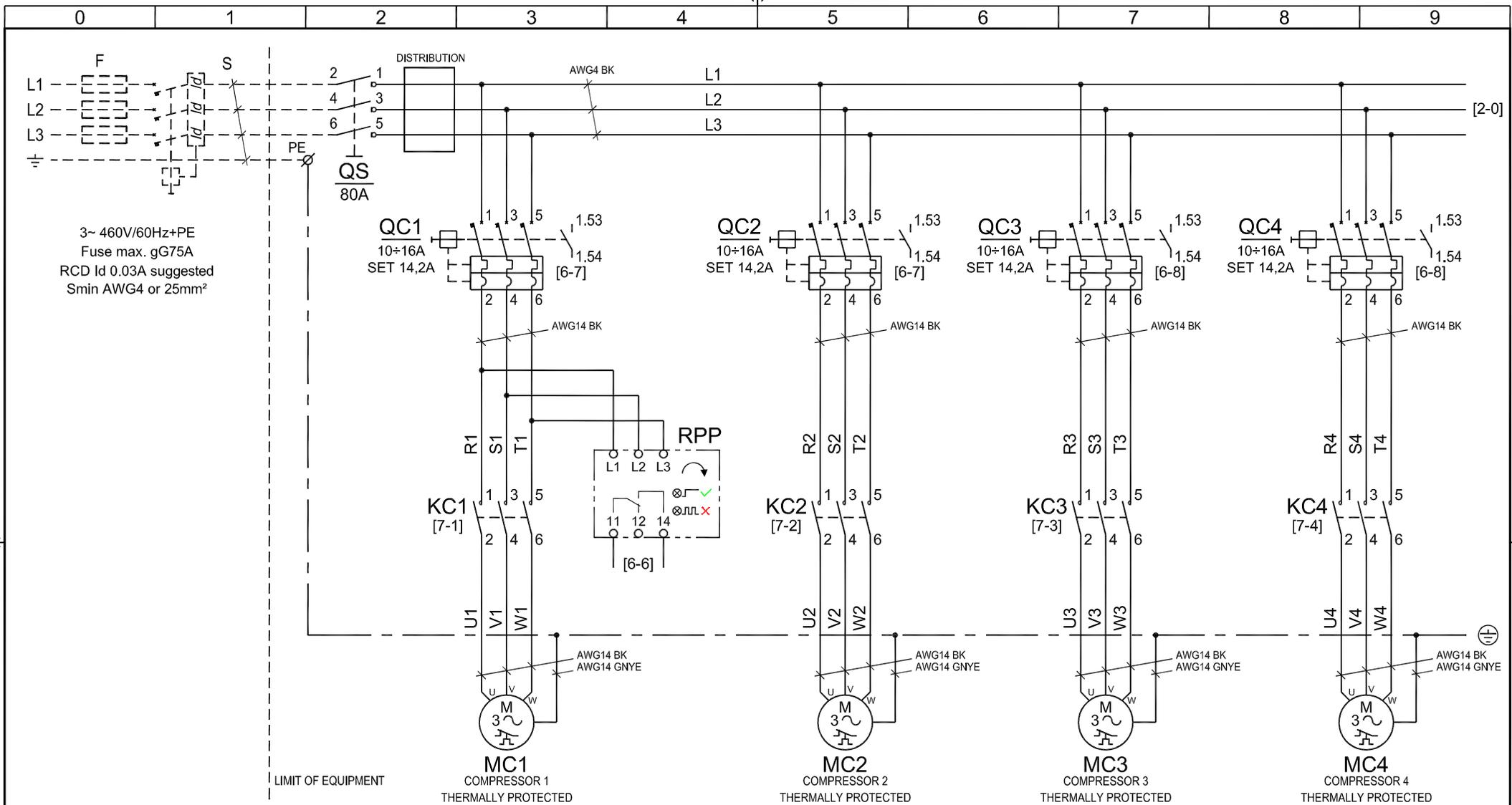

Technical modifications are subject to change without notice; errors not excluded

FRIULAIR
 Dryers

Titolo / Title :

SCHEMA ELETTRICO CWU110
ELECTRICAL DIAGRAM CWU110

FRIULAIR S.r.l. - 33050 CERVIGNANO DEL FRIULI (UD) - ITALY - Via Cisis, 36

Drawing no. : **FRCWU90CWU110R0000**

Rev. **00**

Note :

-

Sheet **1** of **11**

COMPUTER AIDED DESIGN

This drawing cannot be reproduced, copied or given to third parties without FRIULAIR's written authorization

Questo disegno non può essere copiato, riprodotto né ceduto a terzi senza autorizzazione scritta della FRIULAIR S.r.l.

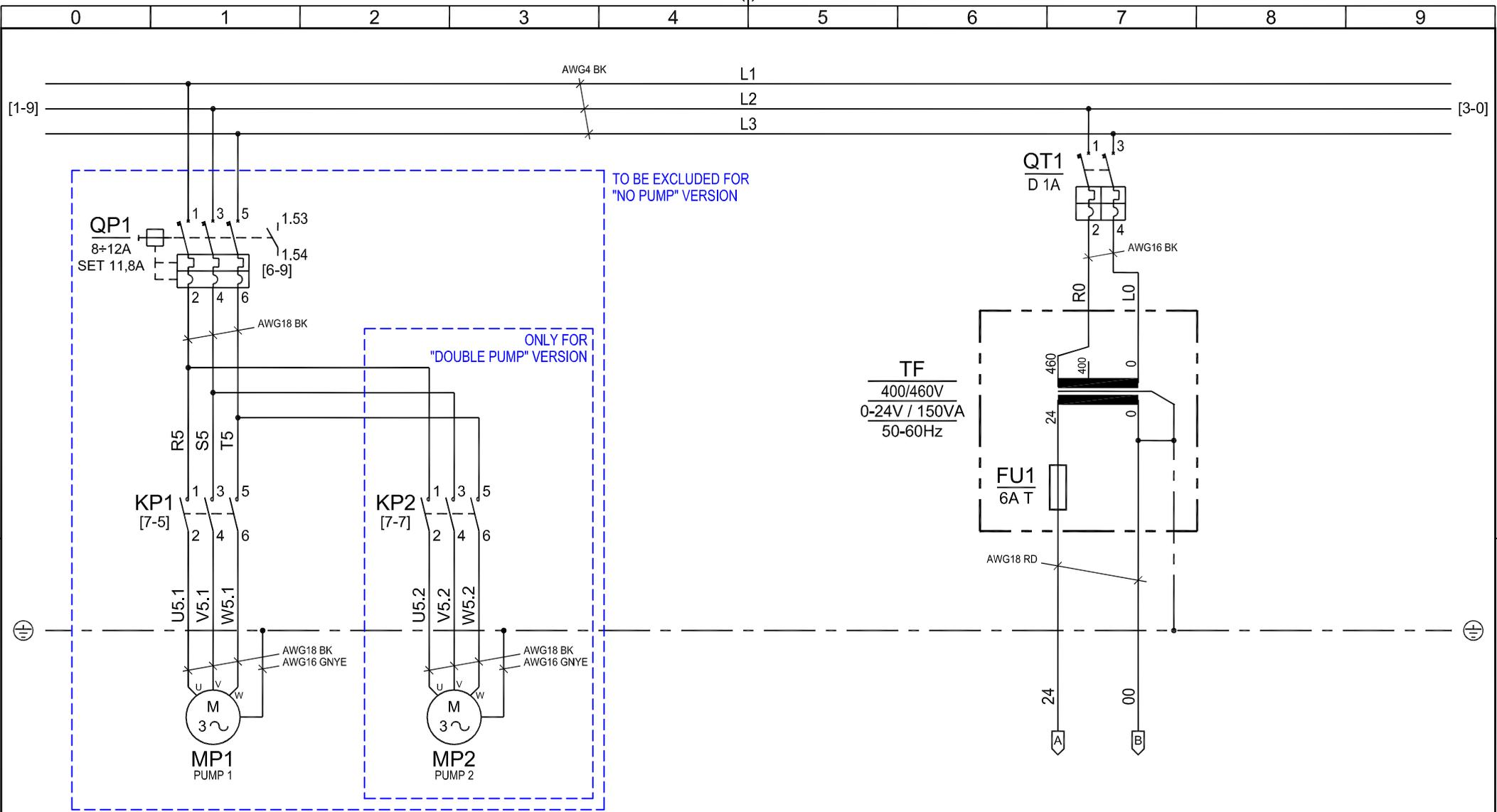

Technical modifications are subject to change without notice; errors not excluded



Titolo / Title : **SCHEMA ELETTRICO CWU110**
ELECTRICAL DIAGRAM CWU110

FRIULAIR S.r.l. - 33050 CERVIGNANO DEL FRIULI (UD) - ITALY - Via Cisis, 36

Drawing no. : **FRCWU90CWU110R0000** Rev. **00**
 Note :
 -

Sheet **2** of **11**

This drawing cannot be reproduced, copied or given to third parties without FRIULAIR's written authorization

Questo disegno non può essere copiato, riprodotto né ceduto a terzi senza autorizzazione scritta della FRIULAIR S.r.l.

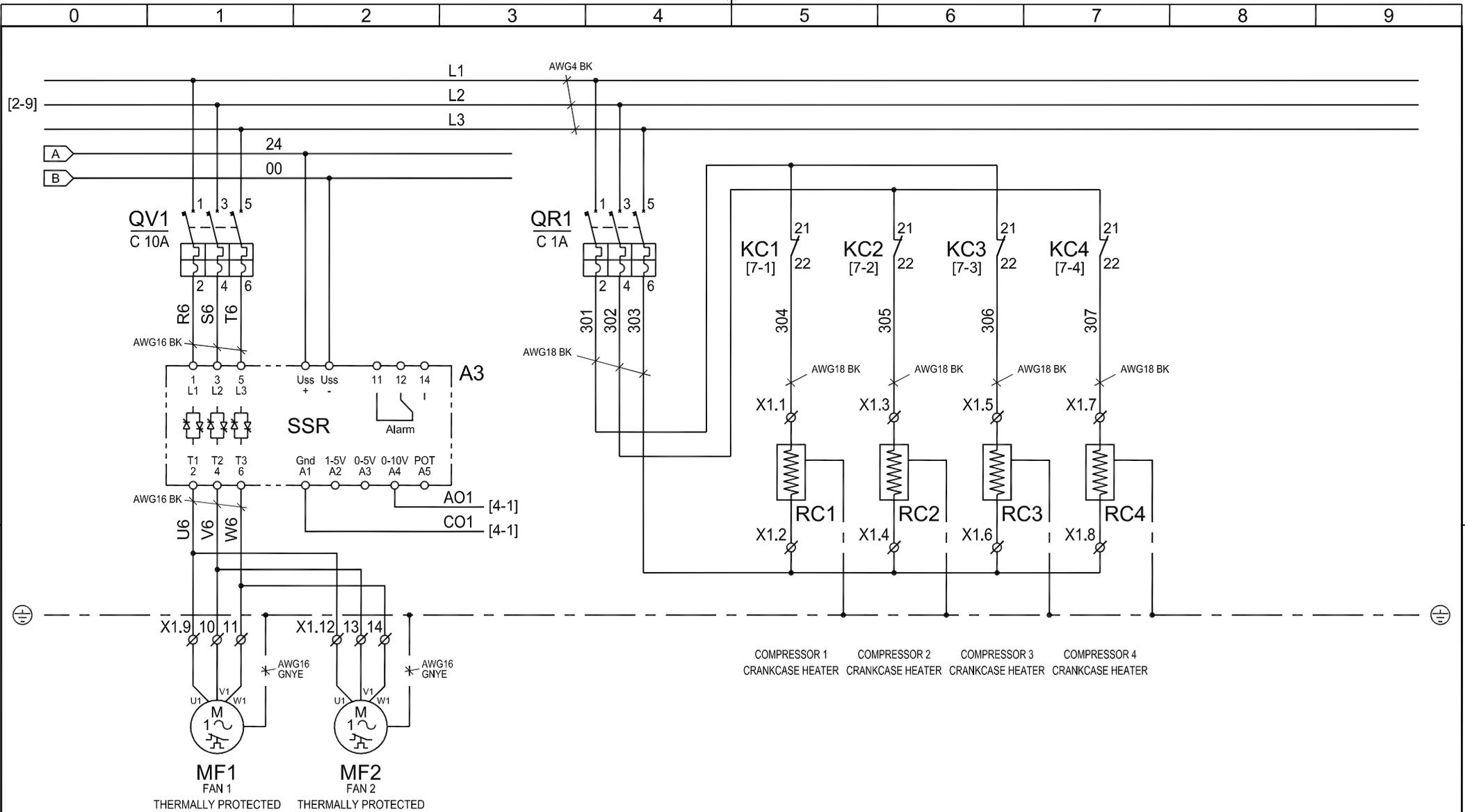

COMPRESSOR 1 COMPRESSOR 2 COMPRESSOR 3 COMPRESSOR 4
 CRANKCASE HEATER CRANKCASE HEATER CRANKCASE HEATER CRANKCASE HEATER

Unless specified AWG18 RD

Technical modifications are subject to change without notice; errors not excluded



Titolo / Title :

SCHEMA ELETTRICO CWU110 ELECTRICAL DIAGRAM CWU110

FRIULAIR S.r.l. - 33050 CERVIGNANO DEL FRIULI (UD) - ITALY - Via Cisis, 36

Drawing no. : FRCWU90CWU110R0000

Rev. 00

Note :

-

Sheet 3 of 11

COMPUTER AIDED DESIGN

This drawing cannot be reproduced, copied or given to third parties without FRIULAIR's written authorization

Questo disegno non puo' essere copiato, riprodotto ne' ceduto a terzi senza autorizzazione scritta della FRIULAIR S.r.l.

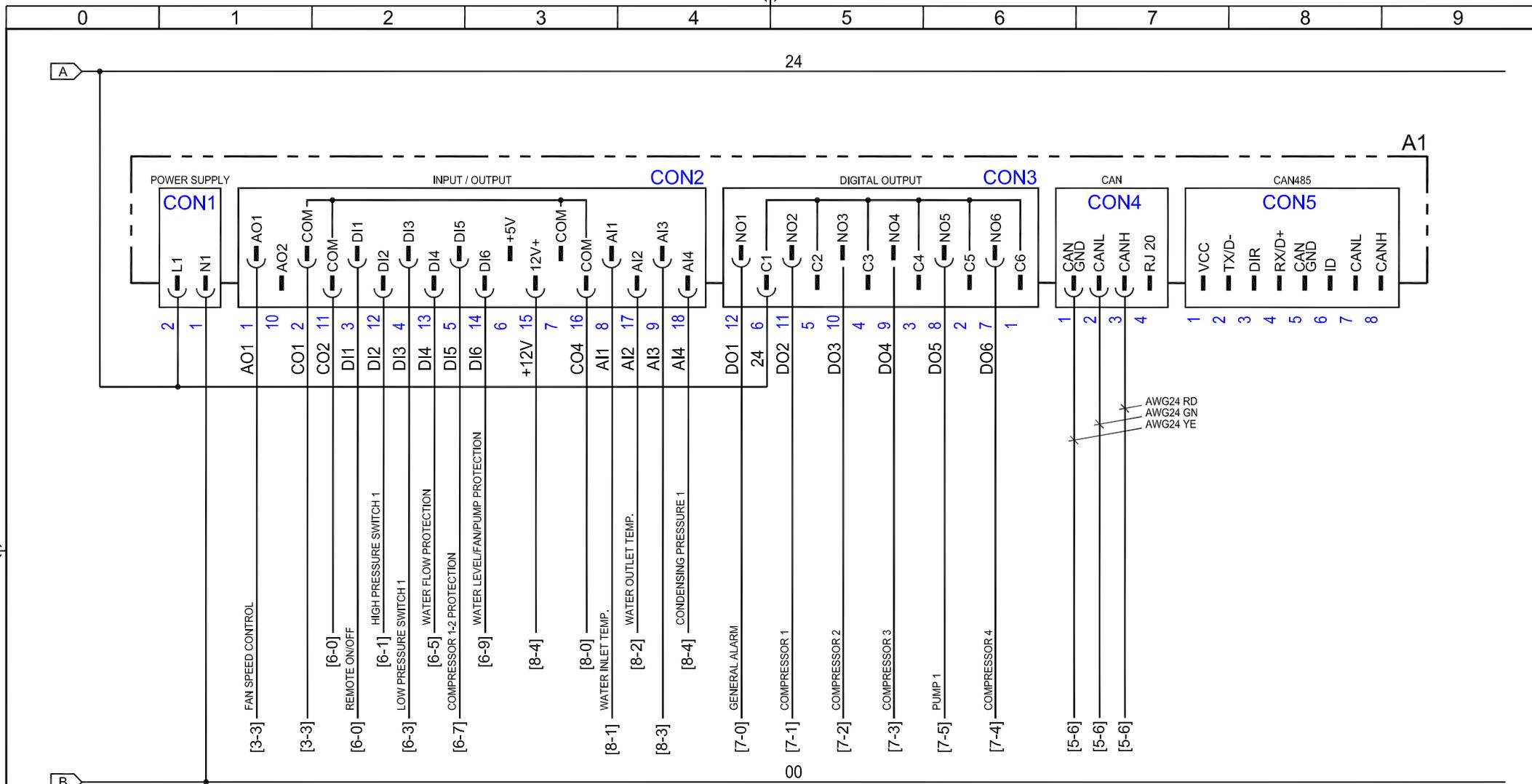

Technical modifications are subject to change without notice; errors not excluded



Titolo / Title :

SCHEMA ELETTRICO CWU110 ELECTRICAL DIAGRAM CWU110

FRIULAIR S.r.l. - 33050 CERVIGNANO DEL FRIULI (UD) - ITALY - Via Cisis, 36

Drawing no. : FRCWU90CWU110R0000

Rev. 00

Note :

-

Sheet 4 of 11

COMPUTER AIDED DESIGN

This drawing cannot be reproduced, copied or given to third parties without FRIULAIR's written authorization

Questo disegno non può essere copiato, riprodotto né ceduto a terzi senza autorizzazione scritta della FRIULAIR S.r.l.

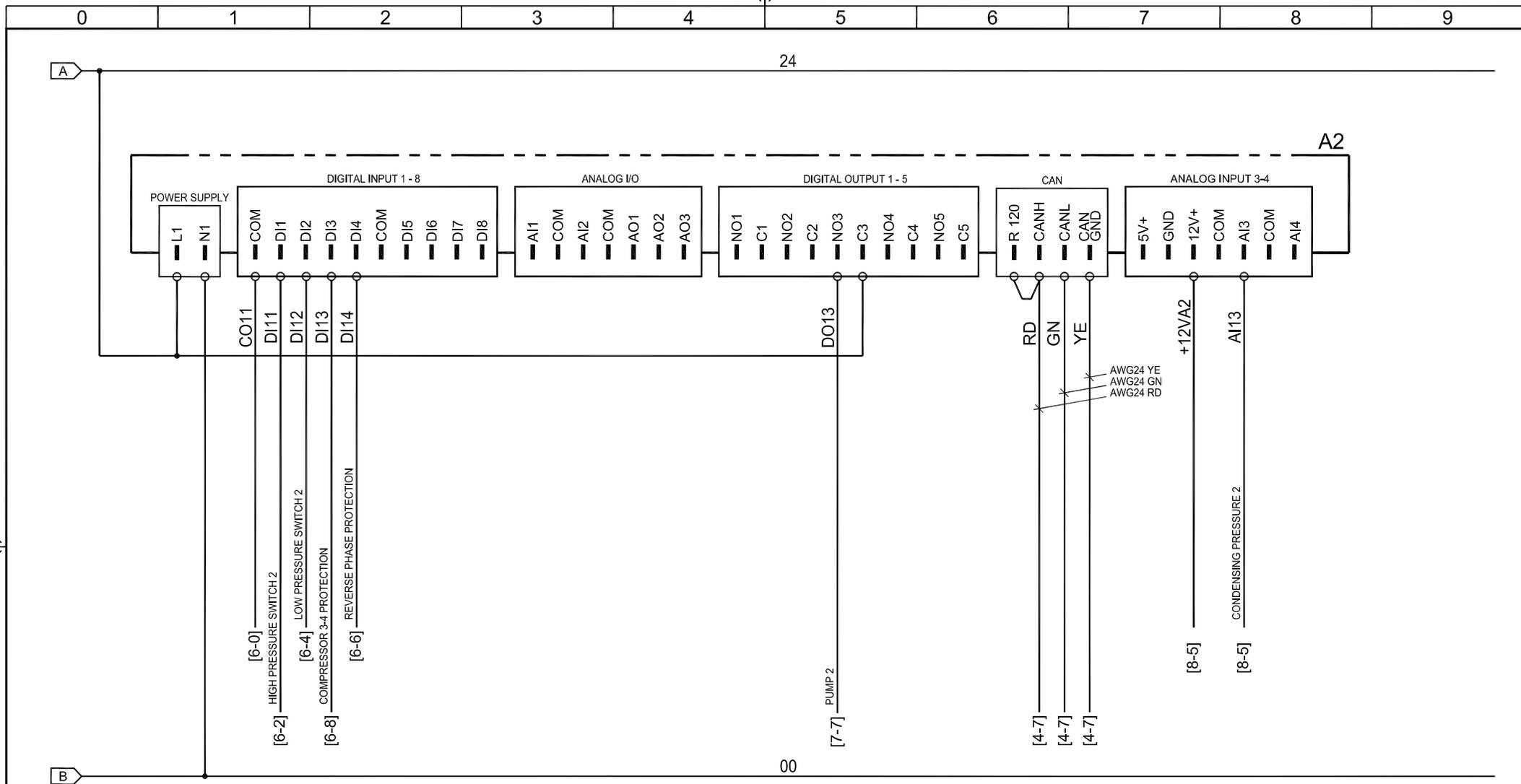

Technical modifications are subject to change without notice; errors not excluded



Titolo / Title : **SCHEMA ELETTRICO CWU110**
ELECTRICAL DIAGRAM CWU110
 FRIULAIR S.r.l. - 33050 CERVIGNANO DEL FRIULI (UD) - ITALY - Via Cisis, 36

Drawing no. : **FRCWU90CWU110R0000** Rev. **00**
 Note :
 - Sheet **5** of **11**

This drawing cannot be reproduced, copied or given to third parties without FRIULAIR's written authorization

Questo disegno non puo' essere copiato, riprodotto ne' ceduto a terzi senza autorizzazione scritta della FRIULAIR S.r.l.

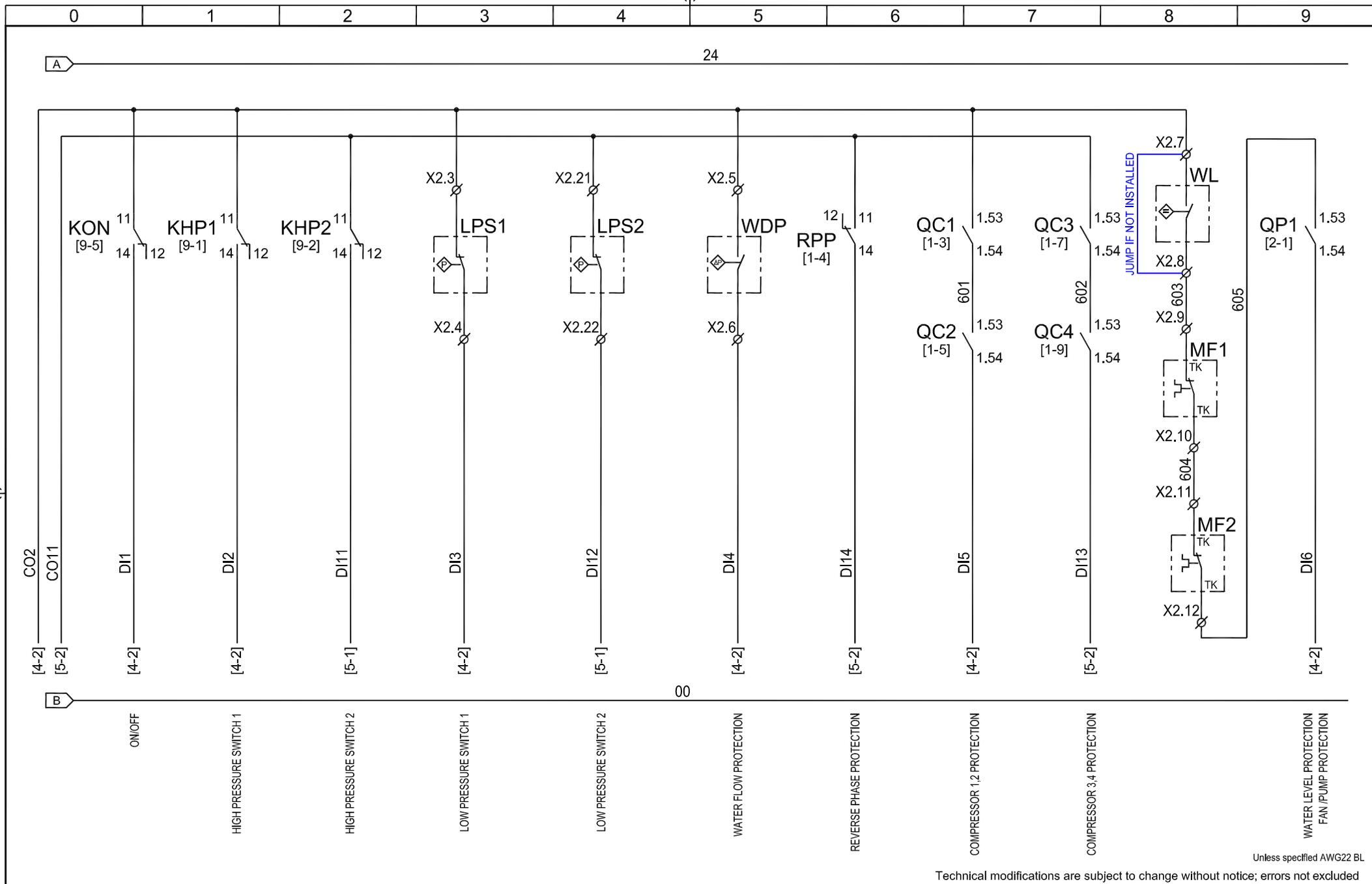

Unless specified AWG22 BL
 Technical modifications are subject to change without notice; errors not excluded



Titolo / Title : **SCHEMA ELETTRICO CWU110**
ELECTRICAL DIAGRAM CWU110
 FRIULAIR S.r.l. - 33050 CERVIGNANO DEL FRIULI (UD) - ITALY - Via Cisis, 36

Drawing no. : **FRCWU90CWU110R0000** Rev. **00**
 Note :
 - Sheet **6** of **11**

This drawing cannot be reproduced, copied or given to third parties without FRIULAIR's written authorization

Questo disegno non può essere copiato, riprodotto né ceduto a terzi senza autorizzazione scritta della FRIULAIR S.r.l.

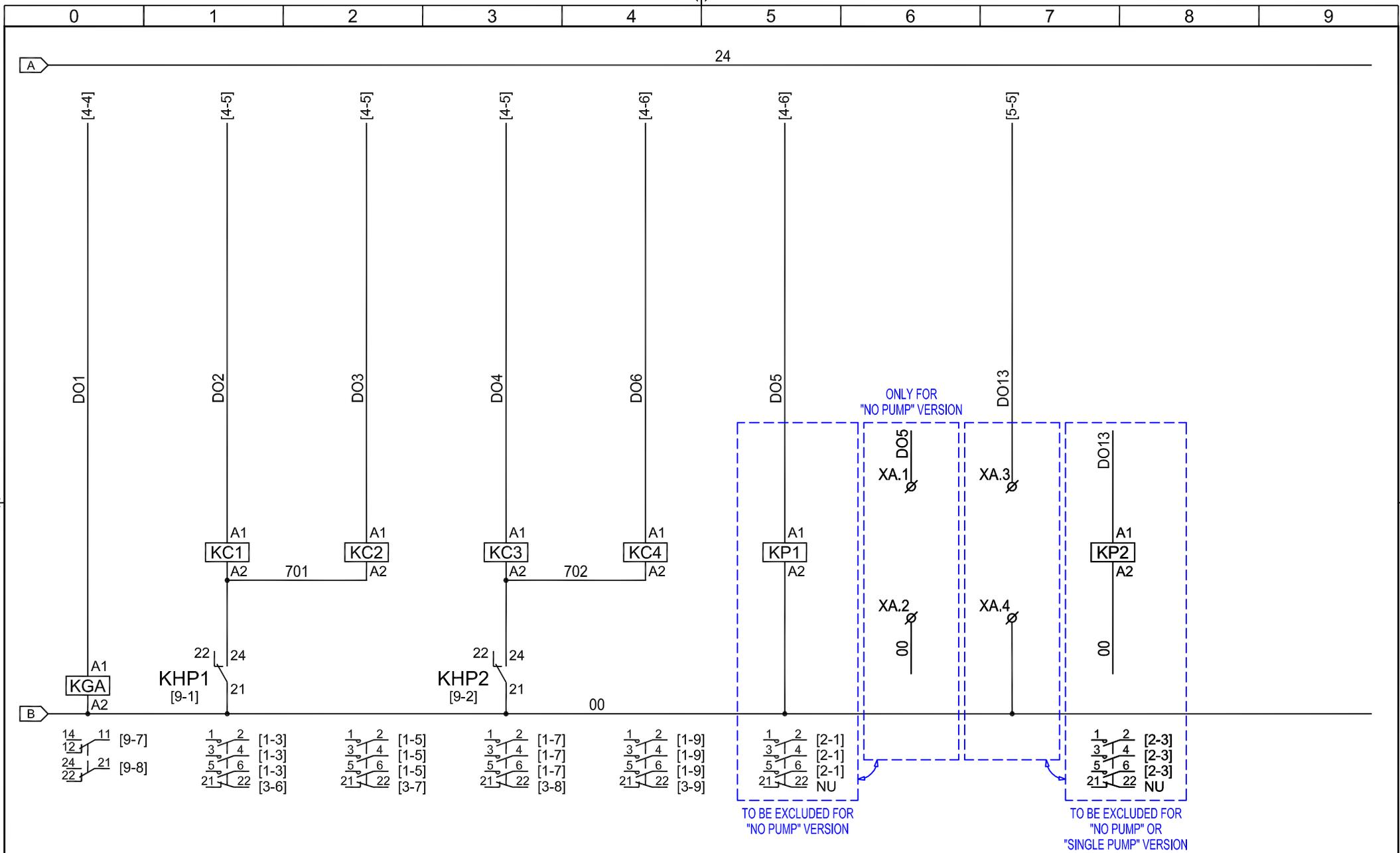

Unless specified AWG18 RD
 Technical modifications are subject to change without notice; errors not excluded



Titolo / Title :

**SCHEMA ELETTRICO CWU110
 ELECTRICAL DIAGRAM CWU110**

FRIULAIR S.r.l. - 33050 CERVIGNANO DEL FRIULI (UD) - ITALY - Via Cisis, 36

Drawing no. :
FRCWU90CWU110R0000

Rev.
00

Note :

-

Sheet **7** of **11**

COMPUTER AIDED DESIGN

This drawing cannot be reproduced, copied or given to third parties without FRIULAIR's written authorization

Questo disegno non può essere copiato, riprodotto né ceduto a terzi senza autorizzazione scritta della FRIULAIR S.r.l.

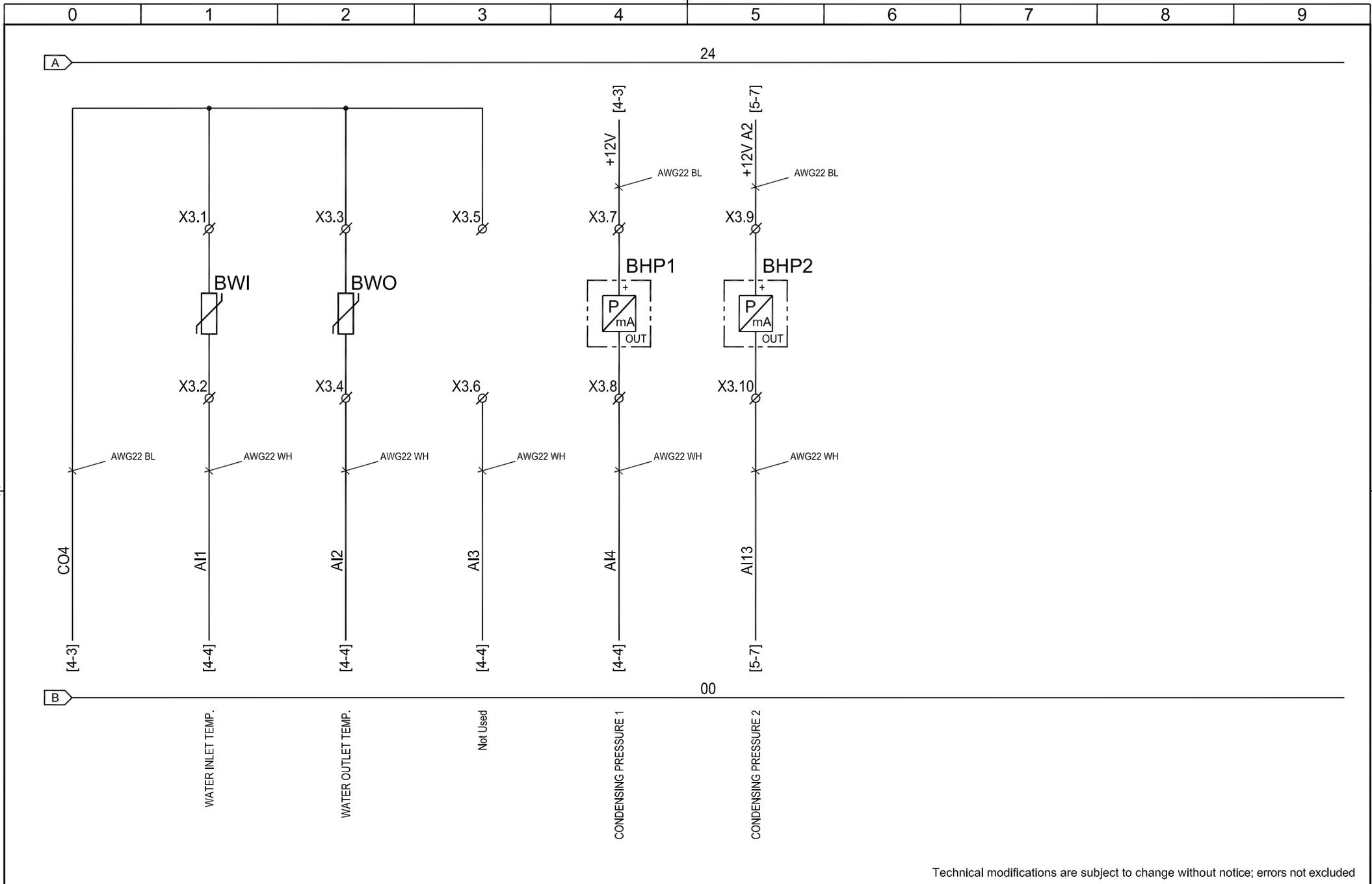

Technical modifications are subject to change without notice; errors not excluded



Titolo / Title :

**SCHEMA ELETTRICO CWU110
ELECTRICAL DIAGRAM CWU110**

FRIULAIR S.r.l. - 33050 CERVIGNANO DEL FRIULI (UD) - ITALY - Via Cisis, 36

Drawing no. : FRCWU90CWU110R0000

Rev. 00

Note :

-

Sheet 8 of 11

COMPUTER AIDED DESIGN

This drawing cannot be reproduced, copied or given to third parties without FRIULAIR's written authorization

Questo disegno non può essere copiato, riprodotto né ceduto a terzi senza autorizzazione scritta della FRIULAIR S.r.l.

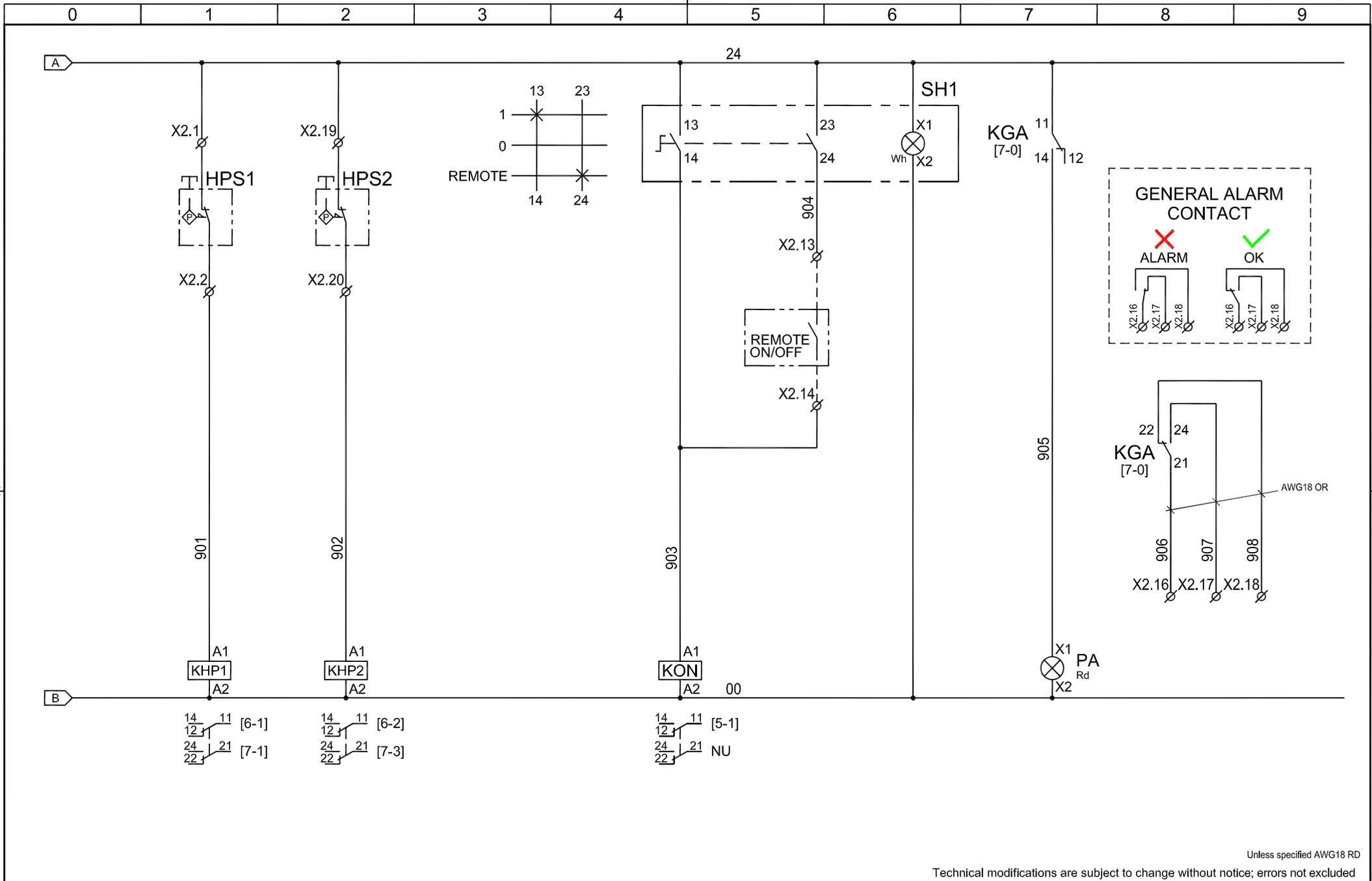

Unless specified AWG18 RD
 Technical modifications are subject to change without notice; errors not excluded

	Titolo / Title :	SCHEMA ELETTRICO CWU110 ELECTRICAL DIAGRAM CWU110	Drawing no. :	Rev.
	FRIULAIR S.r.l. - 33050 CERVIGNANO DEL FRIULI (UD) - ITALY - Via Cisis, 36			FRCWU90CWU110R0000 Note : -

This drawing cannot be reproduced, copied or given to third parties without FRIULAIR's written authorization

Questo disegno non può essere copiato, riprodotto né ceduto a terzi senza autorizzazione scritta della FRIULAIR S.r.l.

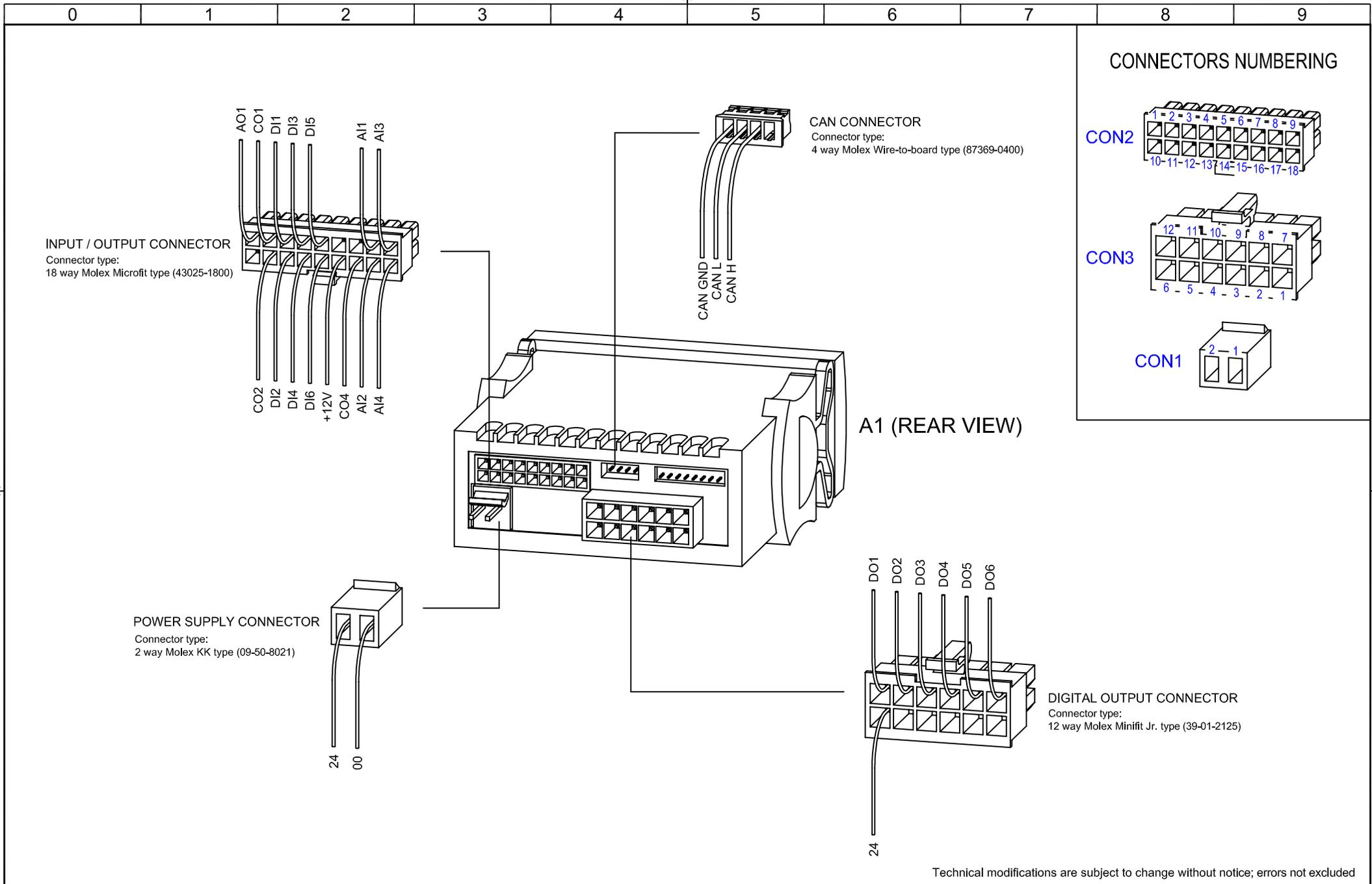

Technical modifications are subject to change without notice; errors not excluded



Titolo / Title :

SCHEMA ELETTRICO CWU110 ELECTRICAL DIAGRAM CWU110

FRIULAIR S.r.l. - 33050 CERVIGNANO DEL FRIULI (UD) - ITALY - Via Cisis, 36

Drawing no. :
FRCWU90CWU110R0000

Rev.
00

Note :

-

Sheet 11 of 11

COMPUTER AIDED DESIGN

Titolo - Title

SCHEMA ELETTRICO CWU130 ELECTRICAL DIAGRAM CWU130

Disegno n° - Drawing nr.

FRCWU90CWU130R0000

Revisione - Revision

00

This drawing cannot be reproduced, copied or given to third parties without FRIULAIR's written authorization

Questo disegno non può essere copiato, riprodotto né ceduto a terzi senza autorizzazione scritta della FRIULAIR S.r.l.

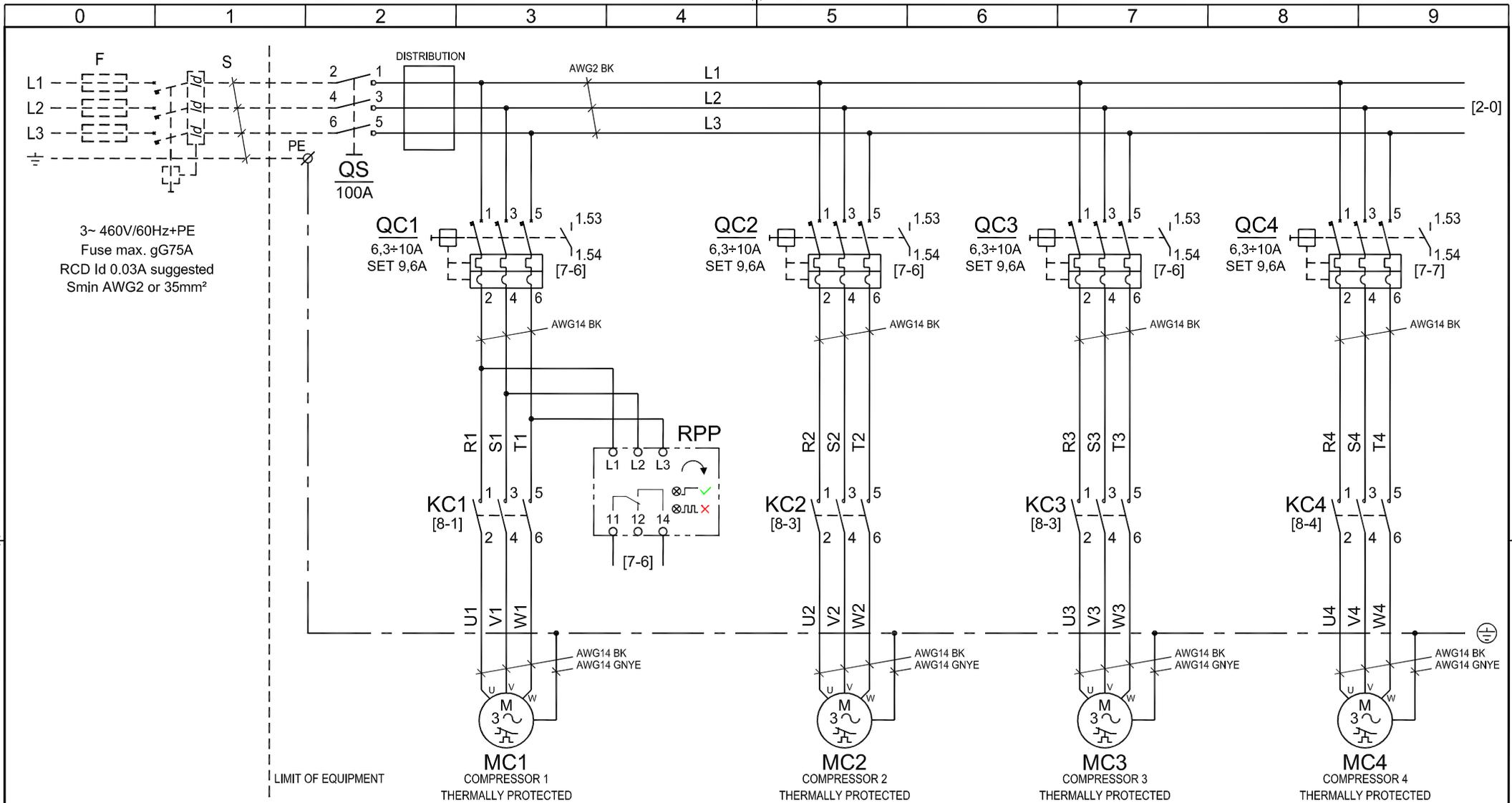

Technical modifications are subject to change without notice; errors not excluded

FRIULAIR
 Dryers

Titolo / Title :

SCHEMA ELETTRICO CWU130
ELECTRICAL DIAGRAM CWU130

FRIULAIR S.r.l. - 33050 CERVIGNANO DEL FRIULI (UD) - ITALY - Via Cisis, 36

Drawing no. :

FRCWU90CWU130R0000

Rev.

00

Note :

-

Sheet **1** of **12**

COMPUTER AIDED DESIGN

This drawing cannot be reproduced, copied or given to third parties without FRIULAIR's written authorization

Questo disegno non può essere copiato, riprodotto né ceduto a terzi senza autorizzazione scritta della FRIULAIR S.r.l.

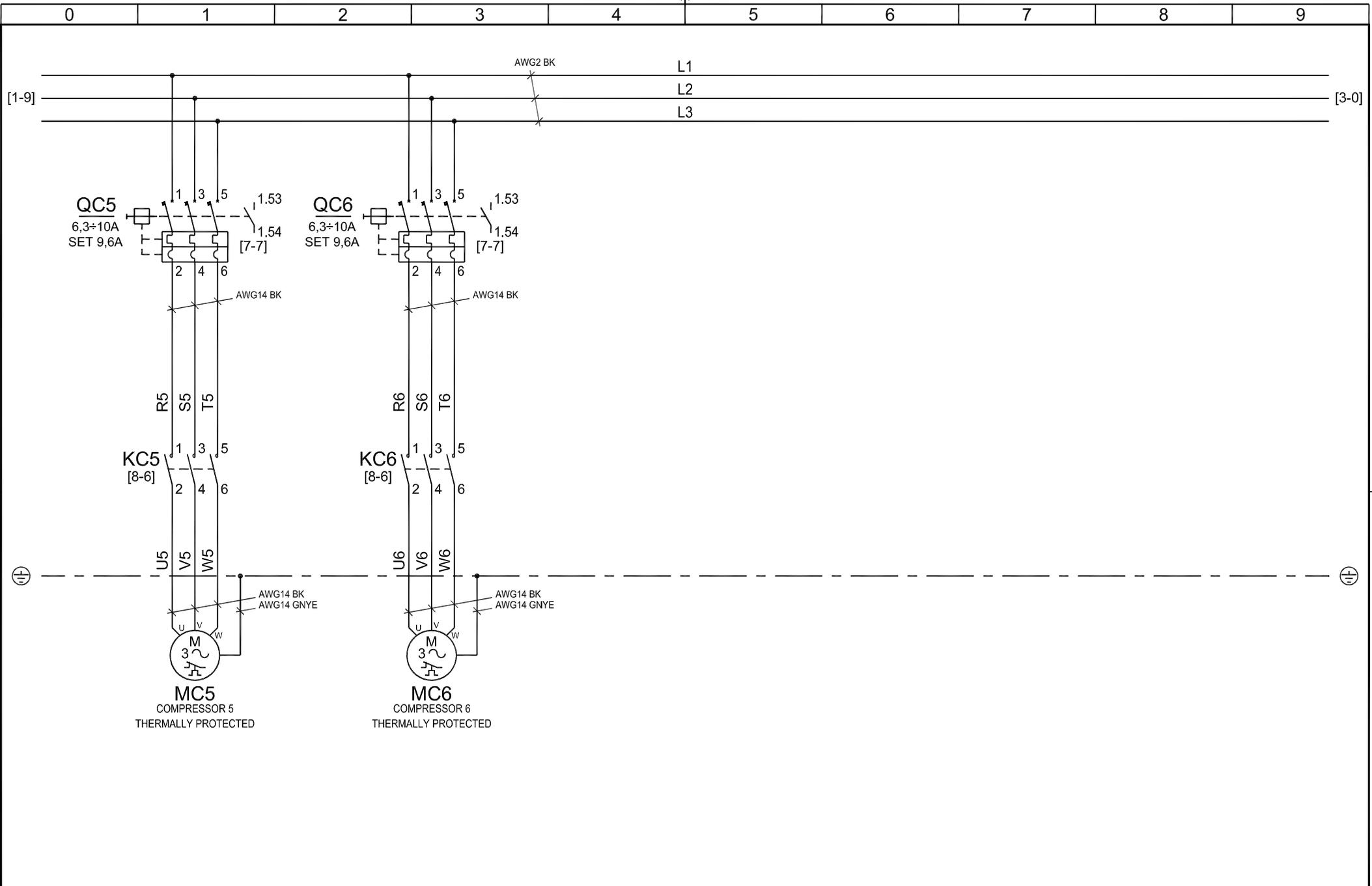

Titolo / Title :

SCHEMA ELETTRICO CWU130 ELECTRICAL DIAGRAM CWU130

FRIULAIR S.r.l. - 33050 CERVIGNANO DEL FRIULI (UD) - ITALY - Via Cisis, 36

Drawing no. :
FRCWU90CWU130R0000

Rev.
00

Note :

-

Sheet 2 of 12

COMPUTER AIDED DESIGN

This drawing cannot be reproduced, copied or given to third parties without FRIULAIR's written authorization

Questo disegno non può essere copiato, riprodotto né ceduto a terzi senza autorizzazione scritta della FRIULAIR S.r.l.

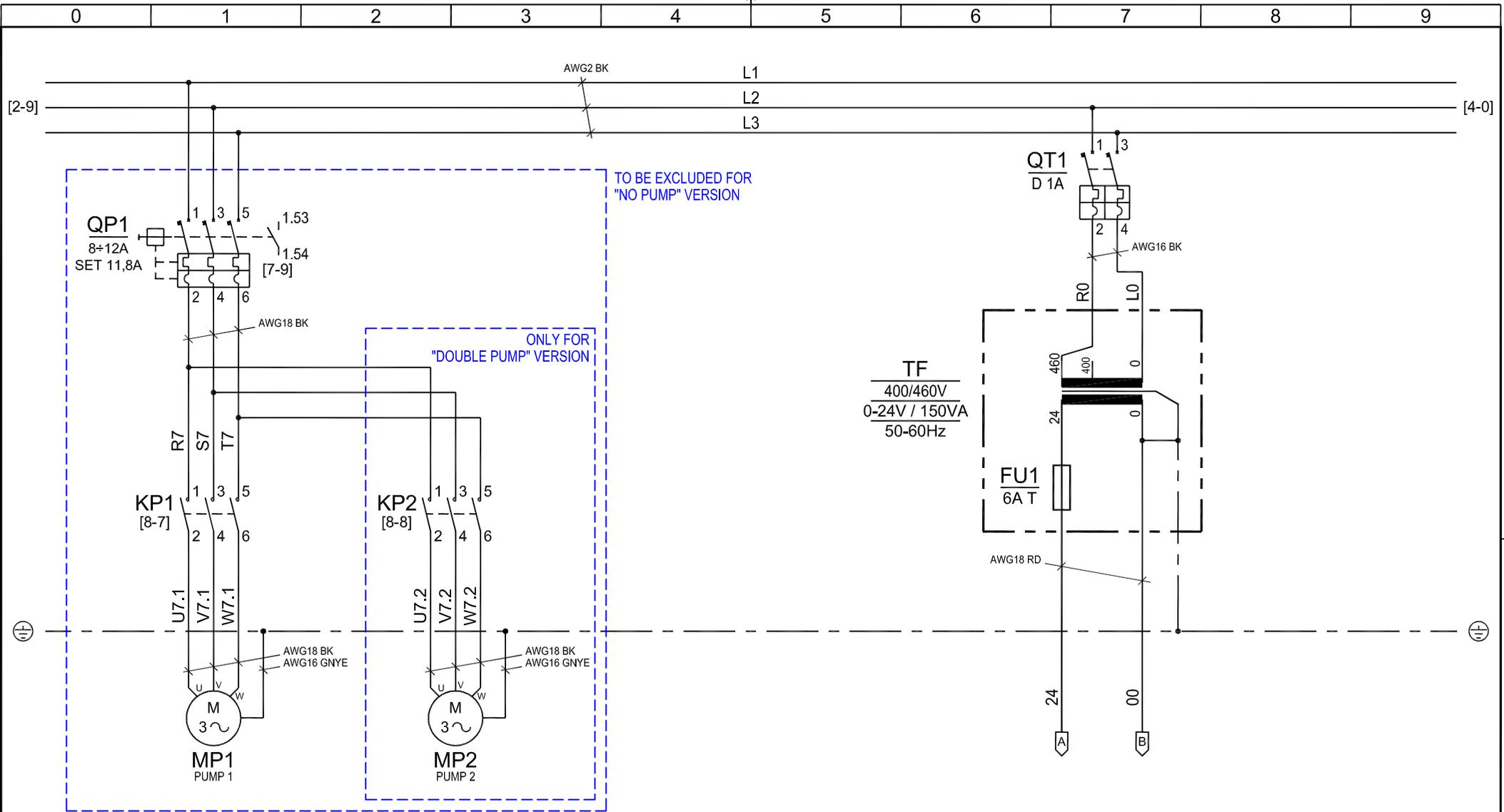

Technical modifications are subject to change without notice; errors not excluded

FRIULAIR
Dryers

Titolo / Title :

SCHEMA ELETTRICO CWU130
ELECTRICAL DIAGRAM CWU130

FRIULAIR S.r.l. - 33050 CERVIGNANO DEL FRIULI (UD) - ITALY - Via Cisis, 36

Drawing no. :
FRCWU90CWU130R0000

Rev.
00

Note :

-

Sheet 3 of 12

COMPUTER AIDED DESIGN

This drawing cannot be reproduced, copied or given to third parties without FRIULAIR's written authorization

Questo disegno non può essere copiato, riprodotto né ceduto a terzi senza autorizzazione scritta della FRIULAIR S.r.l.

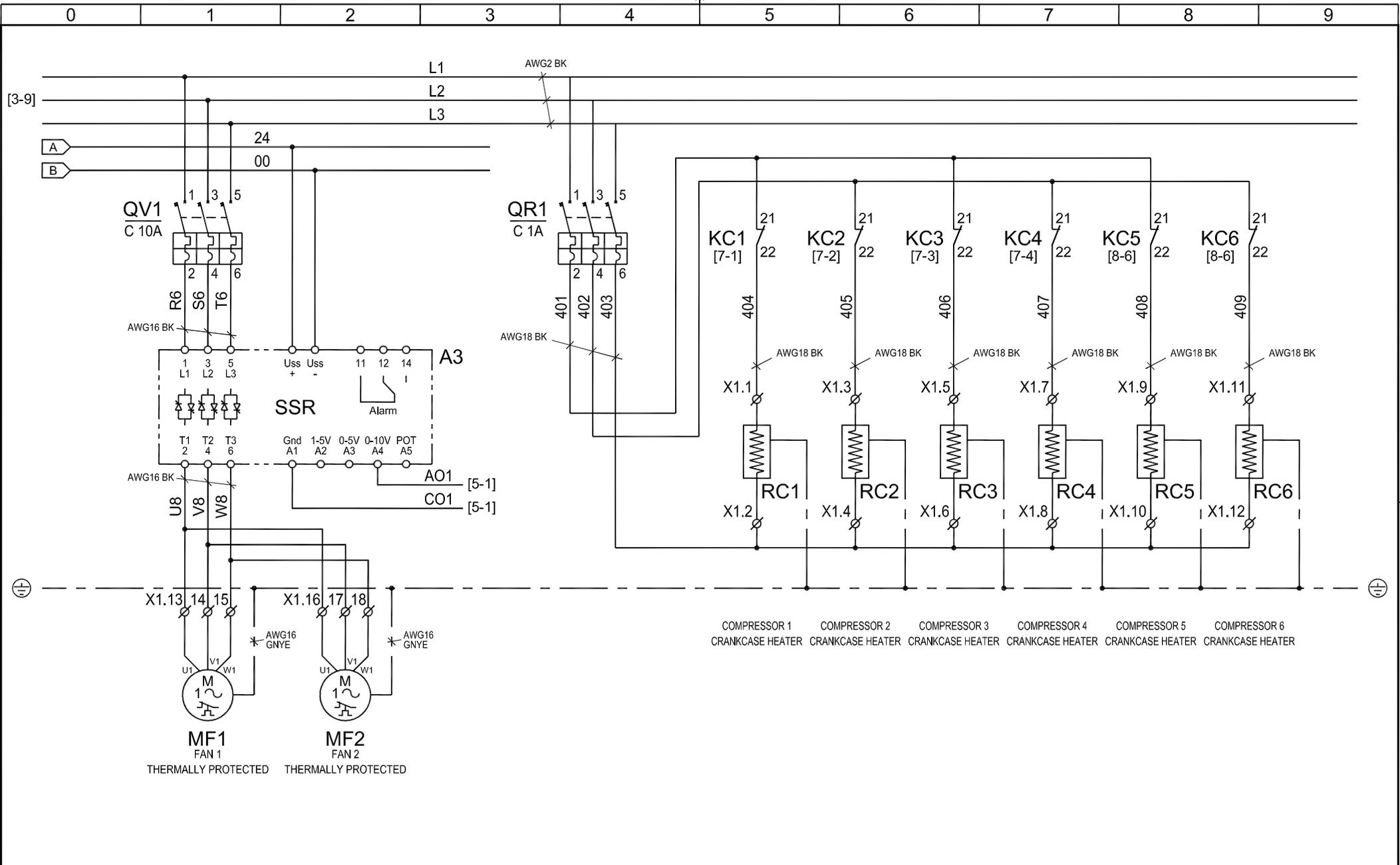

COMPRESSOR 1 COMPRESSOR 2 COMPRESSOR 3 COMPRESSOR 4 COMPRESSOR 5 COMPRESSOR 6
 CRANKCASE HEATER CRANKCASE HEATER CRANKCASE HEATER CRANKCASE HEATER CRANKCASE HEATER CRANKCASE HEATER

Unless specified AWG18 RD
 Technical modifications are subject to change without notice; errors not excluded

	Titolo / Title :	<h2 style="margin: 0;">SCHEMA ELETTRICO CWU130</h2> <h2 style="margin: 0;">ELECTRICAL DIAGRAM CWU130</h2>	Drawing no. : FRCWU90CWU130R0000	Rev. 00
	FRIULAIR S.r.l. - 33050 CERVIGNANO DEL FRIULI (UD) - ITALY - Via Cisis, 36	Note : -	Sheet 4 of 12	COMPUTER AIDED DESIGN

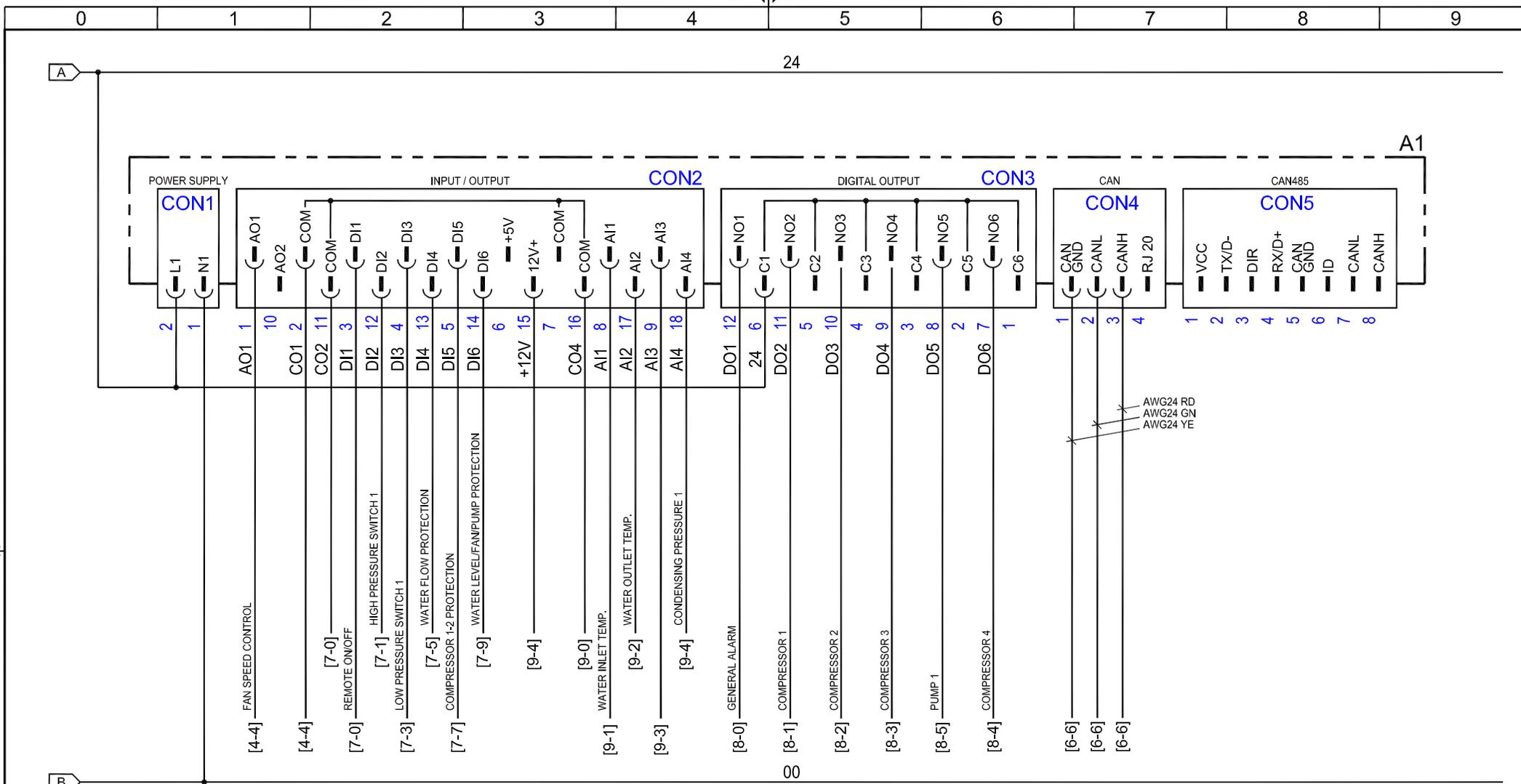

Technical modifications are subject to change without notice; errors not excluded



Titolo / Title :

SCHEMA ELETTRICO CWU130 ELECTRICAL DIAGRAM CWU130

FRIULAIR S.r.l. - 33050 CERVIGNANO DEL FRIULI (UD) - ITALY - Via Cisis, 36

Drawing no. : FRCWU90CWU130R0000

Rev. 00

Note :

-

Sheet 5 of 12

This drawing cannot be reproduced, copied or given to third parties without FRIULAIR's written authorization

Questo disegno non può essere copiato, riprodotto né ceduto a terzi senza autorizzazione scritta della FRIULAIR S.r.l.

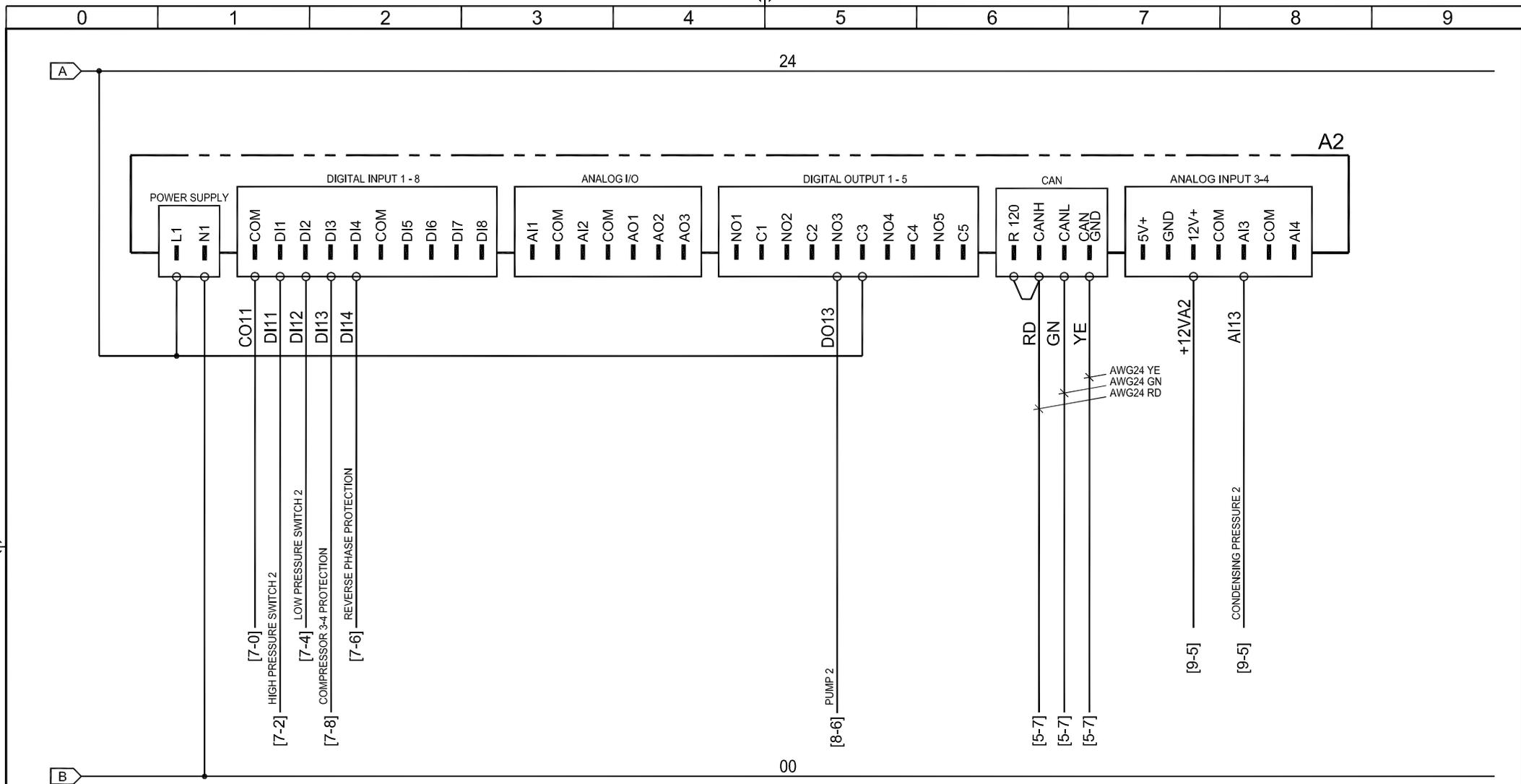

Technical modifications are subject to change without notice; errors not excluded



Titolo / Title :

SCHEMA ELETTRICO CWU130 ELECTRICAL DIAGRAM CWU130

FRIULAIR S.r.l. - 33050 CERVIGNANO DEL FRIULI (UD) - ITALY - Via Cisis, 36

Drawing no. :
FRCWU90CWU130R0000

Rev.
00

Note :

-

Sheet **6** of **12**

COMPUTER AIDED DESIGN

This drawing cannot be reproduced, copied or given to third parties without FRIULAIR's written authorization

Questo disegno non puo' essere copiato, riprodotto ne' ceduto a terzi senza autorizzazione scritta della FRIULAIR S.r.l.

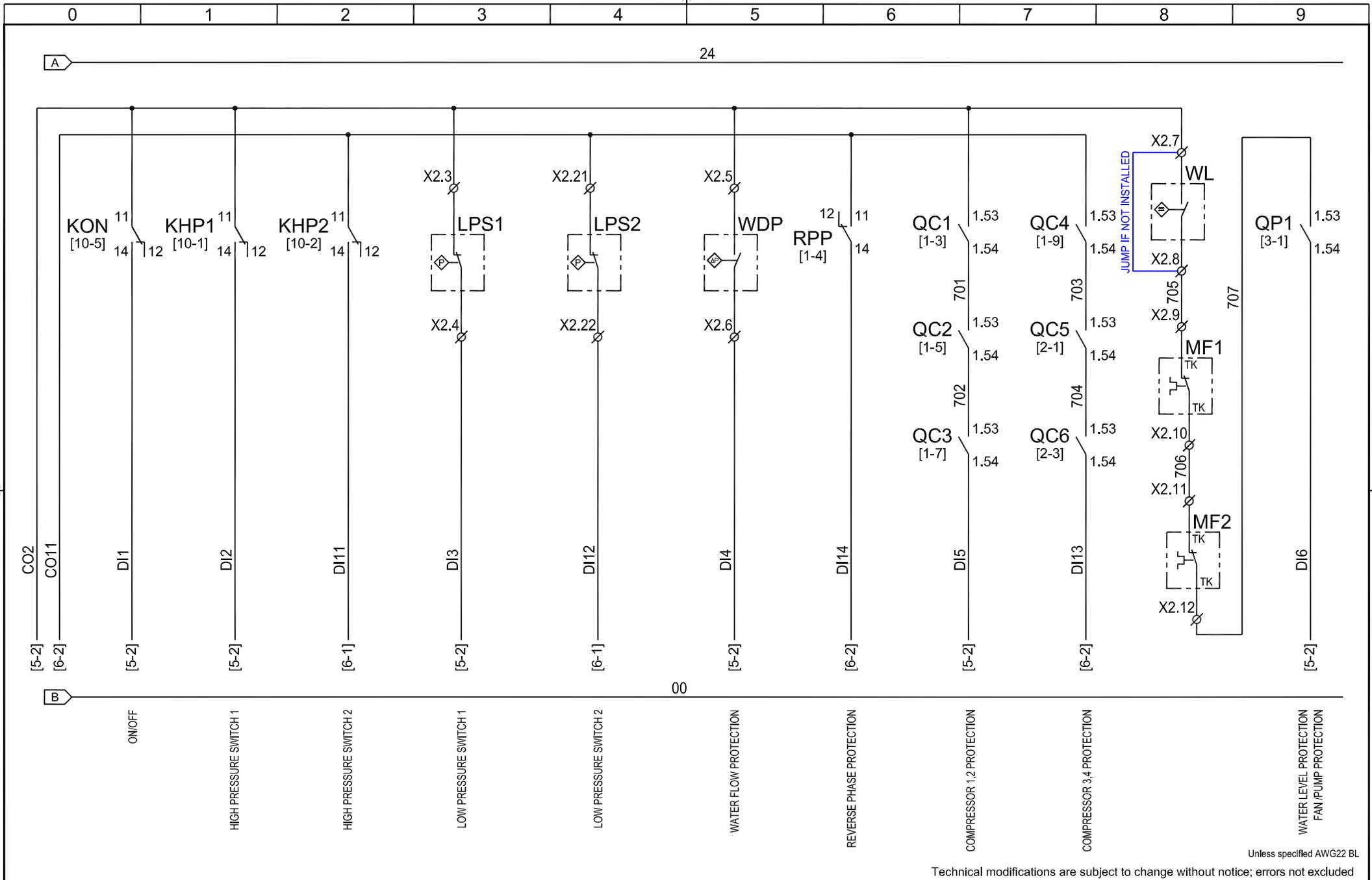

Unless specified AWG22 BL

Technical modifications are subject to change without notice; errors not excluded



Titolo / Title :

SCHEMA ELETTRICO CWU130 ELECTRICAL DIAGRAM CWU130

FRIULAIR S.r.l. - 33050 CERVIGNANO DEL FRIULI (UD) - ITALY - Via Cisis, 36

Drawing no. : FRCWU90CWU130R0000

Rev. 00

Note :

-

Sheet 7 of 12

COMPUTER AIDED DESIGN

This drawing cannot be reproduced, copied or given to third parties without FRIULAIR's written authorization

Questo disegno non può essere copiato, riprodotto né ceduto a terzi senza autorizzazione scritta della FRIULAIR S.r.l.

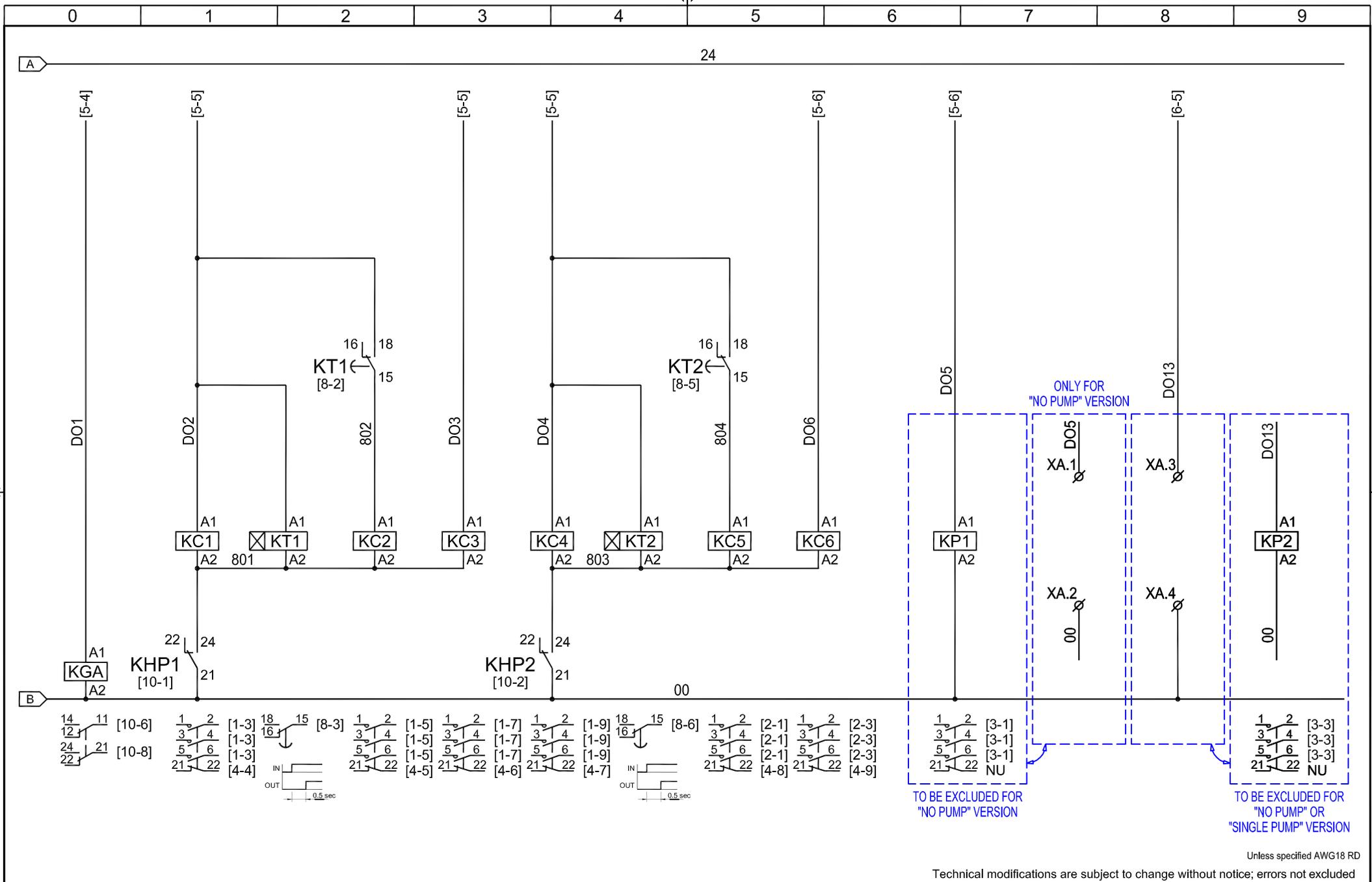

TO BE EXCLUDED FOR "NO PUMP" VERSION

TO BE EXCLUDED FOR "NO PUMP" OR "SINGLE PUMP" VERSION

Unless specified AWG18 RD

Technical modifications are subject to change without notice; errors not excluded



Titolo / Title : **SCHEMA ELETTRICO CWU130**
ELECTRICAL DIAGRAM CWU130

FRIULAIR S.r.l. - 33050 CERVIGNANO DEL FRIULI (UD) - ITALY - Via Cisis, 36

Drawing no. : **FRCWU90CWU130R0000** Rev. **00**

Note : -

Sheet **8** of **12**

COMPUTER AIDED DESIGN

This drawing cannot be reproduced, copied or given to third parties without FRIULAIR's written authorization

Questo disegno non può essere copiato, riprodotto né ceduto a terzi senza autorizzazione scritta della FRIULAIR S.r.l.

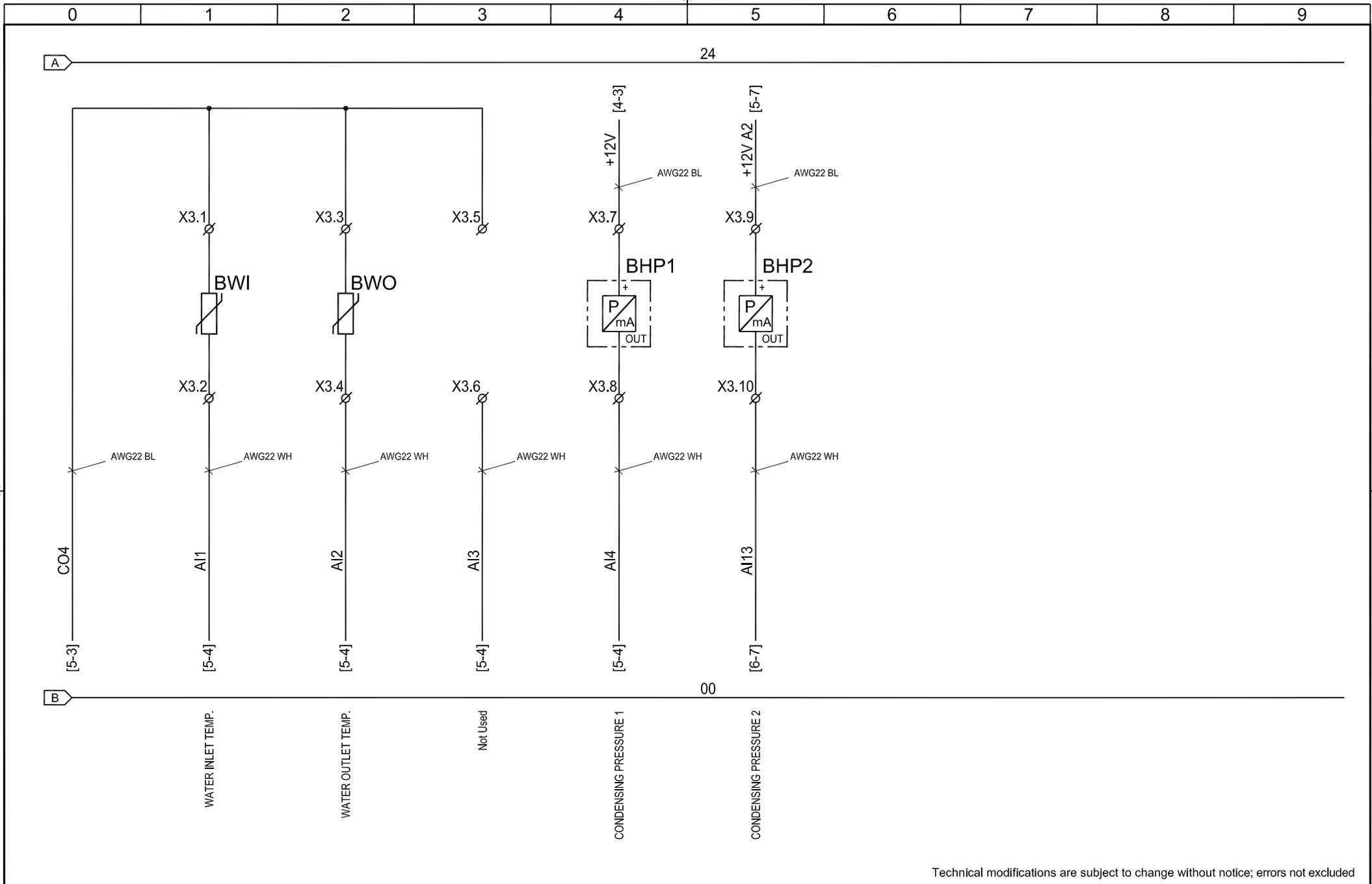

Technical modifications are subject to change without notice; errors not excluded



Titolo / Title :

SCHEMA ELETTRICO CWU130 ELECTRICAL DIAGRAM CWU130

FRIULAIR S.r.l. - 33050 CERVIGNANO DEL FRIULI (UD) - ITALY - Via Cisis, 36

Drawing no. :
FRCWU90CWU130R0000

Rev.
00

Note :

-

Sheet **9** of **12**

COMPUTER AIDED DESIGN

This drawing cannot be reproduced, copied or given to third parties without FRIULAIR's written authorization

Questo disegno non può essere copiato, riprodotto né ceduto a terzi senza autorizzazione scritta della FRIULAIR S.r.l.

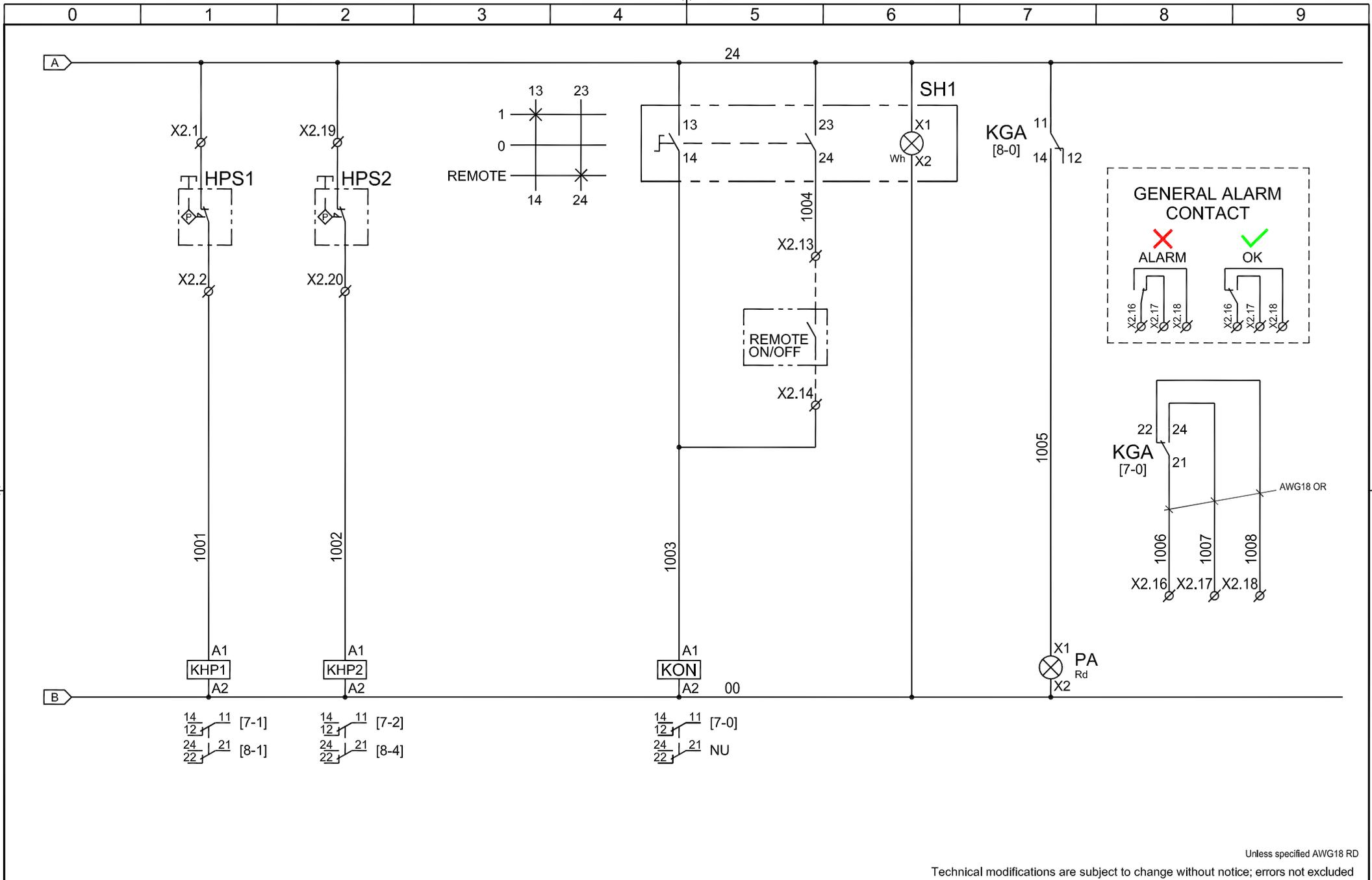

Unless specified AWG18 RD
 Technical modifications are subject to change without notice; errors not excluded



Titolo / Title :

SCHEMA ELETTRICO CWU130 ELECTRICAL DIAGRAM CWU130

FRIULAIR S.r.l. - 33050 CERVIGNANO DEL FRIULI (UD) - ITALY - Via Cisis, 36

Drawing no. : FRCWU90CWU130R0000

Rev. 00

Note :

-

Sheet 10 of 12

COMPUTER AIDED DESIGN

This drawing cannot be reproduced, copied or given to third parties without FRIULAIR's written authorization

Questo disegno non puo' essere copiato, riprodotto ne' ceduto a terzi senza autorizzazione scritta della FRIULAIR S.r.l.

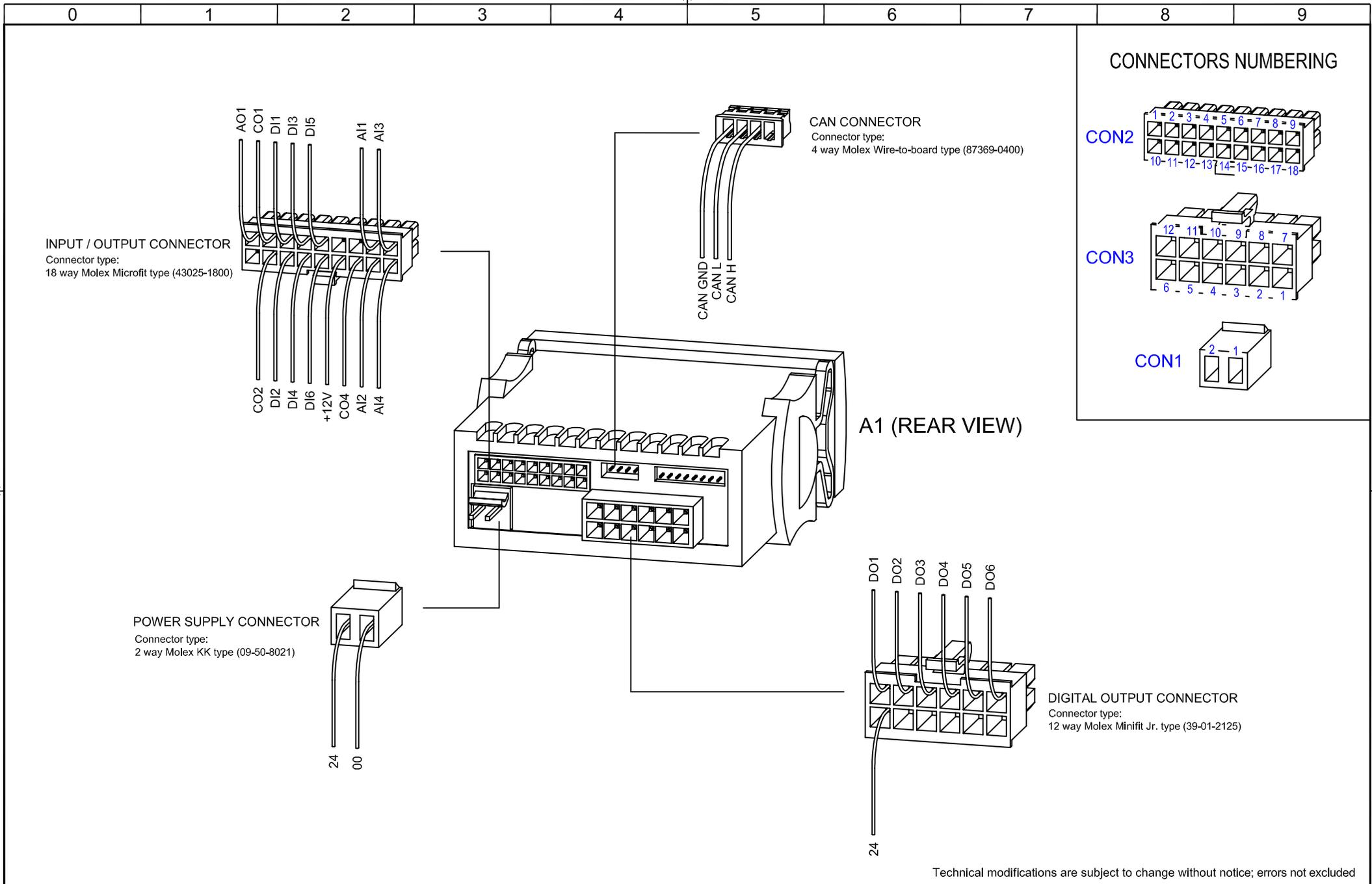

Technical modifications are subject to change without notice; errors not excluded



Titolo / Title :

SCHEMA ELETTRICO CWU130 ELECTRICAL DIAGRAM CWU130

FRIULAIR S.r.l. - 33050 CERVIGNANO DEL FRIULI (UD) - ITALY - Via Cisis, 36

Drawing no. :

FRCWU90CWU130R0000

Rev.

00

Note :

-

Sheet 11 of 12

COMPUTER AIDED DESIGN