

PURESTREAM CWT CHILLERS



BY FRIULAIR



Certified to Canadian Standards



PART-LOAD
LEADER
EFFICIENCY

CWT CHILLER SERIES

CWT PURESTREAM SERIES WATER CHILLERS

The new CWT Purestream chiller range is specifically designed to meet the stringent cooling requirements of today's advanced equipment and processes. The CWT range provides precise temperature control of chilled water temperature while operating over long periods of time with varying load demands for many industries and applications. The range includes several models providing capacities from 2.4 tons to 36.5 tons and designed to be installed indoors or outdoors. The Purestream CWT chillers are equipped with the necessary components to provide reliable effective cooling and energy saving operation. All units are equipped with:

- finned aluminium micro-channel condenser
- rotary or scroll hermetic compressors
- environmentally friendly refrigerant gas R410a
- brazed plate evaporator
- electric fans with continual speed control
- microprocessor controller
- ventilated control panel
- thermally insulated water storage tank
- hydraulic pump
- stainless steel condenser filters
- water filter and shut-off valves

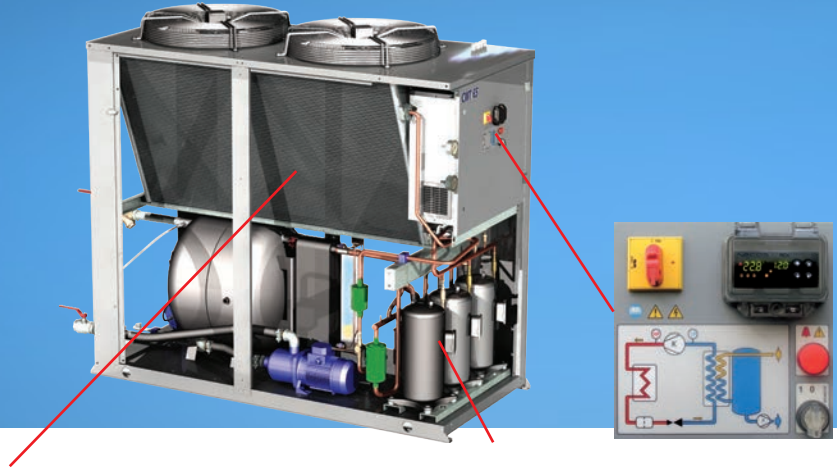

MULTI-CHANNEL ALUMINUM CONDENSERS

The new Micro-channel aluminium plate condensers guarantee a larger surface area providing enhanced heat exchange when compared to the traditional copper tube condensers. The result is a reduction in the refrigerant charge estimated from 30% to 35% less than the traditional condenser design. The all aluminium condensers are treated which makes them resistant to any galvanic reaction and corrosion. To protect the condensers all CWT chillers include stainless steel mesh condenser filters that are easily removed for service and cleaning.

MULTI-COMPRESSOR CONFIGURATION

It is common practice to size chillers for the maximum output required. During normal operating conditions throughout the day and year the maximum output of the chiller is rarely required and for only short periods of time. The CWT chillers use a multiple compressor configuration from model CWT030 and up. This enables the refrigerant system to adapt to the true output required instantaneously. This design results in significant reduction in electrical consumption, a higher efficiency during partial loads because of the over-sized heat exchangers, lower start up current in-rush and an increase in the average life of the compressors. The multi-compressor configuration guarantees higher seasonal energy efficiency verses using a large single compressor unit which would require more energy even in low load periods.

PARTIAL LOAD ENERGY SAVING DESIGN

When the CWT chiller is operating at partial load with only some of the compressors running the efficiency increases because the heat exchangers are now oversized. In effect the CWT chillers with multiple compressors in the same circuit can achieve much better efficiency levels compared with competitive chillers with just one compressor per circuit. The diagram illustrates the CWT multiple compressor design energy saving benefits.

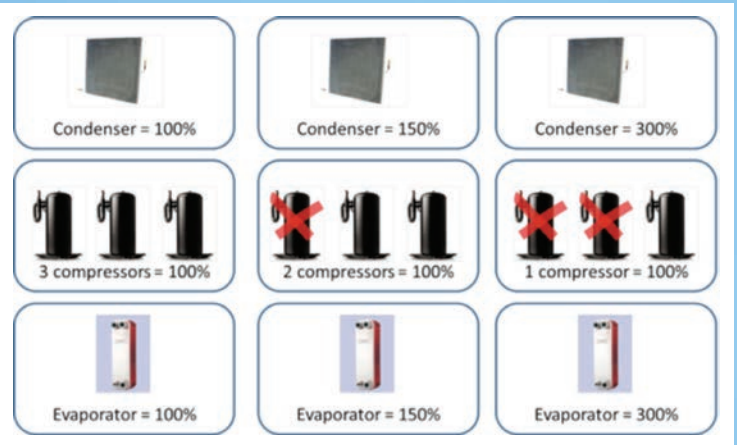

ROTARY AND SCROLL COMPRESSOR

CWT chillers utilize rotary and scroll compressors as a standard. These compressors are the best available technology today for the cooling requirements of the CWT chillers. They are known for their reliability and efficiency through their widespread use in the air conditioning and refrigeration industries. The scroll compressor has the additional benefits of quiet operation, no vibration and the ability to adsorb liquid returns. Compressors are mounted on rubber anti-vibration pads designed to reduce noise and the effects of vibration. They are also protected by an electronic device that monitors the phase sequence in order to avoid reverse rotation. Compressors are all equipped with a crankcase heater as standard.



R410A REFRIGERANT



Due to its thermal dynamic performance, the R410A refrigerant gas allows the refrigeration system to operate at high efficiency. The higher operating pressure of the R410A refrigerant has allowed for the development of a more compact design chiller range.

EVAPORATOR

The stainless steel brazed plate evaporator is compact in size, extremely efficient and installed independent of the storage tank. The electronic control anti-freeze function keeps the evaporator's outlet water temperature under control in order to prevent the evaporator from freezing up. A differential pressure switch protects the evaporator against no or low water flow. A mechanical inlet water filter (standard) protects the entire hydraulic circuit against any contamination coming from the system. The models CWT075 to CWT130 are designed with a double refrigerant circuit and single water circuit. This configuration is very efficient with partial loads, compared to independent evaporator solutions.

REFRIGERANT CIRCUIT

The refrigerant circuit is produced by specialized personnel utilizing high quality materials and rigorous brazing procedures that conform to directive 97/23. The refrigerant circuit consists of: AISI 316 stainless steel brazed plate exchanger, micro-channel aluminium condensers, rotary compressors (models CWT007 and CWT010) and scroll compressors designed for R410A refrigerant, dehydration filter, sight glass humidity indicator, thermostatic expansion valve with external equalisation, reverse flow check valves for models with multi compressors, manual reset high pressure switch and automatic reset low pressure switch, high and low pressure gauges and refrigerant maintenance connection points.

HYDRAULIC CIRCUIT

Composed of a thermally insulated storage tank made of carbon steel or stainless steel c/w: expansion tank, shut-off ball valves, by-pass valve, safety valve, automatic venting valve, differential pressure switch, level sensor, water filter, drain valve, pressure gauge and multi-stage centrifugal electric pump with high efficiency impeller. The high liquid volume to compressor cooling capacity ratio maintains a constant outlet water temperature while minimizing compressor starts and stops. Where the multi-compressor configuration is used the storage tank is smaller which allows for a faster start up to reach plant cooling water requirements. The water storage tank is positioned on the water outlet in order to limit temperature fluctuations due to the compressors being switched on and off. Within the unit there is also a small by-pass tube between the water inlet and outlet designed to prevent problems caused by water valves being closed unintentionally.

HYDRAULIC CIRCUIT



CIRCULATION PUMPS

All units are equipped with a high efficiency multi-stage centrifugal pump with steel impeller. All parts coming in contact with fluid are AISI 304 stainless steel. The mechanical seals are carbon/ceramic/EPDM as standard therefore making it possible to use water and ethylene glycol mixtures of up to 30%. The pump motor is 2-pole, self-ventilated, with class F insulation and IP55 protection level. The entire CWT series chillers utilize P3 pump pressure as standard and optional P5 pressure. Double pump option is also available upon request.



FRAME AND CABINET

All frame and cabinetry material are made from galvanized steel and painted in a powder coat paint finish. This allows for indoor and outdoor installation and provides protection in harsh environments. All fasteners are either stainless steel or electro-galvanized materials. The CWT cabinet was designed so that all parts, particularly those requiring maintenance and cleaning are easy to access without interfering with the chiller operation. The chiller cabinet is accessible on three sides allowing for easy maintenance and also designed with safety to the operator in mind.

FANS

The 4/6/8 pole axial fan motors are complete with an external rotor blade which is activated by condensing pressure measured by a pressure transducer. This leads to more regular operation and lower usage which extends the lifespan of the fan motor. All fans have a protection grill, thermally heat protected with automatic reset and class F insulation.

CONTROL PANEL

The control panel complies with the Canadian electrical code and includes door lock disconnect which prevents access to the control panel when it is powered. The watertight door provides easy access to the electronic controller as well as the numbered panel wires provide easy trouble shooting and maintenance. Each control panel includes: thermo-magnetic motor protectors for the compressors and pump, contactors, autotransformers, compressor rotation direction control devices, ON/OFF switch on the panel door. The control panel also includes an active ventilation system to prevent over heating when the unit is in operation.



CWT CHILLER SERIES

MICROPROCESSOR CONTROLLER

The electronic control micro-processor controls and optimizes all CWT chiller components and functions. The controller regulates the evaporator water outlet temperature, switches pump on and off, regulates fan speed, controls the compressors on and off cycles based on water temperature required, while guaranteeing equal operating times to protect the compressors for multi-compressor machines, measurement and display of evaporator inlet and outlet temperature, measurement and display of condensation pressure, control of multiple pump chillers designed to ensure equal pump operating times. The controller also provides the following alarm messages:

- High refrigerant pressure gauge
- low refrigerant pressure gauge
- water differential pressure gauge
- compressor thermal/phase sequence control
- pump thermal protection
- temperature probe failure
- pressure probe failure
- high water temperature
- anti-freeze



User interface is easy and intuitive and the controller can be enabled for "remote" function with its clear and visible alarm indicator. The easy-to-follow set up menu allows for easy access to set main operating parameters. The integrated double display with its bright digital characters provides a complete real time display of the chiller operation and alarm conditions.

FACTORY TESTING

All CWT chillers are factory tested in Canada prior to shipping.

PRESSURE OPERATED BYPASS VALVES

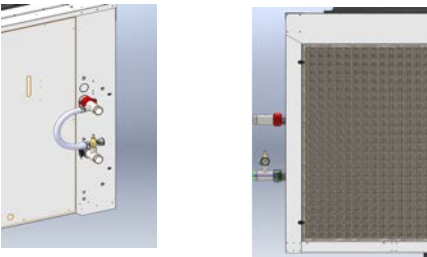

The Primary function is to protect the chiller should any number of situations impede flow.

Located between the supply and return on the outlet of the chiller it is designed to open should the pressure in the closed loop go beyond the preset level.

The POBV will respond to the increased pressure by opening and begin bypassing water or Glycol to the Return Line. The chiller will sense the reduction in load and adjust the number of compressors running or shut off completely.

The Secondary Function will also allow a single PURESTREAM CHILLER with Adaptable load Operation to supply Chilled Water or Glycol to multiple loads.

An example would be in the brewing industry or any cooling loop that has previously been setup to run with City Water. Water is diverted around the brewing process depending on what step the process is in. Often these systems have a switch that opens and closes feed water into the cooling jacket in the fermentation tank or in the Wort Chiller. In a chiller without a bypass valve, this would not be possible as closing the valve would DEADHEAD the pump. The POBV will open to allow the system to continue to run at a lower loop flow and also scale back the refrigeration effect to match the load.

APPLICATIONS

- Breweries, distilling
- Plastics (injection, blow moulding, extrusion, film extrusion, thermoforming)
- Printing and Graphics (manufacture, printing, cardboard, labels, plastic film)
- Medical imaging
- Food (beverage, confectionary, chocolate, processing, storage)
- Mechanical (welding, cutting, profiling, polishing, rolling, grinding)
- Other (wood, ceramics, gold, biogas pharmaceutical, compressed air, textile)
- Hydraulic circuit cooling, Machine Tool
- Paint and Finishing
- EDM

SAFETY AND CONTROL DEVICES

- Low Ambient Wind Panels for Canadian winters.
- Non-Ferrous design (Now standard for Canada).
- Temperature probes control and display evaporator inlet and outlet water temperatures to prevent freeze-ups.
- A high pressure gauge/switch signals the chiller to stop operation if it experiences irregular refrigerant pressure on the circuit's high pressure side. Once the problem is corrected it can be manually reset.
- A low pressure gauge stops the chiller if the refrigerant pressures are too low and the reset is automatic once the pressure has returned to the preset value.
- A pressure transducer registers high refrigeration system pressure allowing fan speed regulation with a phase - cutting electronic regulator that allows the chiller to work with an outdoor air temperature of up to 14°F.
- A level sensor is installed on water storage tank which stops the chiller if water capacity is too low.
- A water differential pressure gauge/switch stops the chiller if water capacity is too low.
- In order to prevent compressors from rotating in the opposite direction and incurring damage a phase sequence control stops the chiller from operating if the electric power phase sequence is accidentally reversed.

TECHNICAL DATA

CWT Unit		020	038	040	065	075	090	130	150
Cooling capacity	Tons	5.3	9	10.9	15.6	17.5	21.5	32.2	35.50
Cooling capacity	kW	21.3	39.9	43.9	61.9	77.8	94.9	127.4	146.2
Compressor power input	kW	5.0	7.1	10.0	16.1	14.0	19.6	30.8	32.23
Total power input	kW	7.2	12.8	14.3	24.2	25.1	32.9	41.6	44.18
Total absorbed current	A	8.7	15.6	17.3	28.7	30.4	38.8	49.7	55.12
EER (pump excluded)	--	11.4	13.3	11.9	10.3	10.8	10.32	10.8	11.2
Water flow	gal/min	16.1	27.3	33.1	47.1	53.3	65.5	97.3	94.54
Available pressure	psig	48.9	50.8	37.3	45.3	42.5	34.6	55.0	55.2
Maximum power input (total)	kW	9.4	17.3	18.9	30	34.6	42.3	54.5	57.2
Maximum absorbed current (total)	A	10.8	20	21.7	34.2	39.4	47.9	62	67.6
Starting current	A	55	59.4	65.8	99	78.9	99	126.8	148.1
Fan power	kW	1.2	1.2	1.2	2.9	2.9	2.9	2.5	2.50
Fan current	A	1.6	1.6	1.6	3.7	3.7	3.7	3.4	3.40
Number of fans	#	1	2	2	2	2	2	2	2
Pump power input	kW	1	2	2	2.9	2.9	2.9	6.9	6.95
Pump absorbed current	A	1.2	2.4	2.4	3.3	3.3	3.3	8.1	8.12
Refrigerant	--	R410A							
Power supply	V/Ph/Hz	575/3/60							
Compressor type	--	Scroll							
Evaporator type	--	Brazed plates							
Condenser type	--	Microchannel							
N° of compressors	#	1	2	2	2	4	4	4	4
N° of refrigerant circuits	#	1	1	1	1	2	2	2	2
Air flow	cfm	4814	9063	9063	11060	19382	19382	26006	26006
Sound pressure level	dB(A)	50.0	53.0	53.0	49.5	58.5	58.5	52.0	52.0
Water connection diameter	inch	1"	1 1/2"	1 1/2"	1 1/2"	2"	2"	2"	2"
Tank capacity	gal	25.1	35.7	35.7	35.7	54.2	54.2	54.2	54.2
Expansion vessel capacity	gal	1.3	2.1	2.1	2.1	3.2	3.2	3.2	3.2
Maximum pressure in hydraulic circuit	psig	87	87	87	87	87	87	87	87
IP protection degree	--	IP44	IP44	IP44	IP44	IP44	IP44	IP44	IP44
Width	inch	26.1	29.6	29.6	32.8	43.7	43.7	47.6	47.6
Depth	inch	51.4	64.4	64.4	72.8	79.7	79.7	87.8	87.8
Height	inch	56.1	60.4	60.4	66.9	74.8	74.8	88.8	88.8
Weight	lb	606	882	904	1135	1587	1698	2205	2205
Pump power input	kW	1.3	2.5	2.5	4.0	4.0	4.0	on demand	on demand
Pump absorbed current	A	2.5	4.3	4.3	7.5	7.5	7.5	on demand	on demand
Available pressure	psig	77.8	81.2	64.9	71.3	67.1	57.1	on demand	on demand

TECHNICAL DATA

CWT Unit		010	015	018	020	030	038	040
Cooling capacity ⁽¹⁾	Tons	2.1	3.4	4.4	5.3	6.5	9	10.9
Cooling capacity ⁽¹⁾	kW	7.4	11.9	15.4	18.7	22.8	31.5	38.4
Compressors power input ⁽¹⁾	kW	1.8	3.2	3.6	5.0	6.7	7.1	10.0
Total power input ^{(1) (2)}	kW	2.9	4.4	4.8	6.3	7.9	9.8	12.7
Total absorbed current ^{(1) (2)}	A	5.30	7.44	9.56	11.72	13.80	18.45	22.75
EER (pump excluded) ⁽¹⁾	--	11.7	11.15	13.0	11.4	10.9	13.3	11.9
Water Flow ⁽¹⁾	gal/min	6.4	10.2	13.3	16.1	19.5	27.3	33.1
Available pressure ^{(1) (2)}	psig	55.5	39.1	54.0	48.9	42.2	50.8	37.3
Maximum power input (total) ^{(2) (3)}	kW	3.9	5.8	7.2	8.5	10.6	14.7	17.1
Maximum absorbed current (total) ^{(2) (3)}	A	6.6	9.5	12.6	14.5	17.6	24.6	28.4
Starting current ^{(2) (3)}	A	35.7	41.7	58.1	74.1	49.9	70.1	88.0
Fan power	kW	0.40	0.40	0.50	0.50	0.50	0.50	0.50
Fan current	A	1.80	1.80	4.60	4.60	4.60	4.60	4.60
Number of fans	#	1	1	1	1	1	2	2
Pump power input ⁽²⁾	kW	0.74	0.74	0.74	0.74	0.74	1.70	1.70
Pump absorbed current ⁽²⁾	A	1.80	1.80	1.80	1.80	1.80	2.98	2.98
Refrigerant	--	R410A						
Power supply	Voltage	460/3/60						
Compressor type	--	Rotary	Scroll					
Evaporator type	--	Brazen plates						
Condenser type	--	Microchannel						
N° of compressors	#	1	1	1	1	2	2	2
N° of refrigerant circuits	#	1	1	1	1	1	1	1
Air Flow	cfm	2558	2667	4814	4814	4738	9063	9063
Sound pressure level ⁽⁴⁾	dB(A)	43.0	43.0	50.0	50.0	50.0	53.0	53.0
Water connections diameter NPT	"	1"	1"	1"	1"	1"	1 1/2"	1 1/2"
Tank capacity	gal	25.1	25.1	25.1	25.1	25.1	35.7	35.7
Expansion vessel capacity	gal	1.3	1.3	1.3	1.3	1.3	2.1	2.1
Maximum pressure in hydraulic circuit	psig	87						
IP protection degree	--	IP44						
Width	inch	26.1	26.1	26.1	26.1	26.1	29.6	29.6
Depth	inch	39.0	39.0	51.4	51.4	51.4	64.4	64.4
Height	inch	52.6	52.6	56.1	56.1	56.1	60.4	60.4
Weight	lb	474	573	584	606	717	882	904
P5 PUMP DATA								
Pump power input	kW	0.7	0.7	1.3	1.3	1.3	2.5	2.5
Pump absorbed current	A	1.8	1.8	2.5	2.5	2.5	4.3	4.3
Available pressure ^{(1) (5)}	psig	85.8	61.6	85.4	77.8	67.0	81.2	64.9

(1) Data based on the following conditions: water temperature in/out: 59/50°F (15/10°C) - ambient air temperature: 77°F (25°C)

(2) Data based on unit with standard P3 pump

(3) Data based on worst conditions allowed by safety devices fitted on the unit

(4) Based on 10 meter distance in an open environment

(5) Data based on unit with P5 pump (optional)

(6) For models from CWT010 to CWT065 with additional loading tank, length increases by 12 inches.

CWT Unit		045	055	065	075	090	110	130	150
Cooling capacity	Tons	10.3	13.0	15.6	17.5	21.5	26.4	32.2	35.50
Cooling capacity	kW	36.1	45.8	54.8	61.5	75.5	92.7	113.1	146.2
Compressor power input	kW	9.4	11.4	16.1	14.0	19.6	20.7	30.8	32.23
Total power input	kW	12.9	16.0	20.7	21.9	27.5	31.9	42.0	44.18
Total absorbed current	A	22.67	26.28	33.18	34.06	42.47	49.99	65.04	55.12
EER (pump excluded)	--	11.9	11.6	10.3	10.8	10.32	12.32	10.8	11.2
Water flow	gal/min	31.1	39.5	47.1	53.3	65.5	80.4	97.3	94.54
Available pressure	psig	50.7	48.0	45.3	42.5	34.6	56.9	55.0	55.2
Maximum power input (total)	kW	17.6	22.6	26.2	31.9	36.7	43.7	54.5	57.2
Maximum absorbed current (total)	A	29.2	34.6	40.3	46.7	54.3	67.9	81.0	67.6
Starting current	A	61.4	80.1	99.9	92.2	113.9	145.5	140.6	148.1
Fan power	kW	0.50	1.05	1.05	2.70	2.70	2.70	2.50	2.50
Fan current	A	4.60	4.80	4.80	4.20	4.20	4.20	4.20	3.40
Number of fans	#	1	2	2	2	2	2	2	2
Pump power input	kW	2.50	2.50	2.50	2.50	2.50	6.20	6.20	6.95
Pump absorbed current	A	4.30	4.30	4.30	4.30	4.30	10.20	10.20	8.12
Refrigerant	--	R410A							
Power supply	V/Ph/Hz	460/3/60							
Compressor type	--	Scroll							
Evaporator type	--	Brazen plates							
Condenser type	--	Microchannel							
N° of compressors	#	3	3	3	4	4	4	6	4
N° of refrigerant circuits	#	1	1	1	2	2	2	2	2
Air flow	cfm	9063	11060	11060	19382	19382	26006	26006	26006
Sound pressure level	dB(A)	53.0	49.5	49.5	58.5	58.5	52.0	52.0	52.0
Water connection diameter	inch	1 1/2"	1 1/2"	1 1/2"	2"	2"	2"	2"	2"
Tank capacity	gal	35.7	35.7	35.7	54.2	54.2	54.2	54.2	54.2
Expansion vessel capacity	gal	2.1	2.1	2.1	3.2	3.2	3.2	3.2	3.2
Maximum pressure in hydraulic circuit	psig	87	87	87	87	87	87	87	87
IP protection degree	--	IP44	IP44	IP44	IP44	IP44	IP44	IP44	IP44
Width	inch	32.8	32.8	32.8	43.7	43.7	47.6	47.6	47.6
Depth	inch	72.8	72.8	72.8	79.7	79.7	79.7	87.8	87.8
Height	inch	66.9	66.9	66.9	74.8	74.8	88.8	88.8	88.8
Weight	lb	1102	1102	1135	1587	1698	2161	2205	2205
Pump power input	kW	4.0	4.0	4.0	4.0	4.0	on demand	on demand	on demand
Pump absorbed current	A	7.5	7.5	7.5	7.5	7.5	on demand	on demand	on demand
Available pressure	psig	80.6	75.8	71.3	67.1	57.1	on demand	on demand	on demand

DIMENSIONAL DATA

ALL DATA IN INCHES

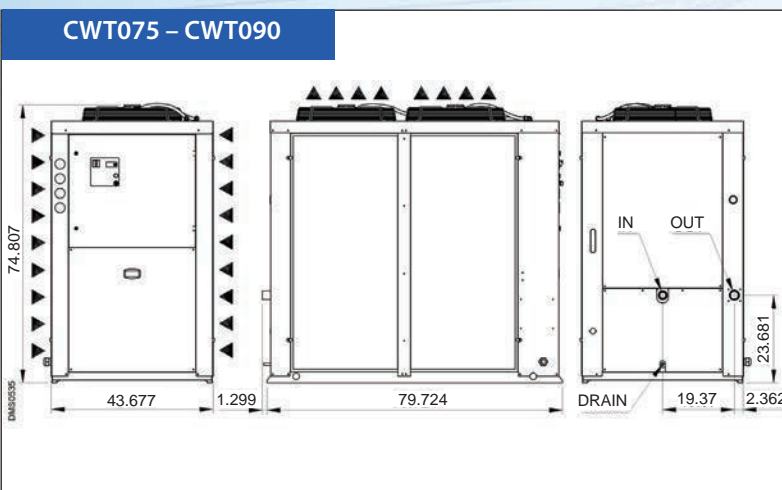
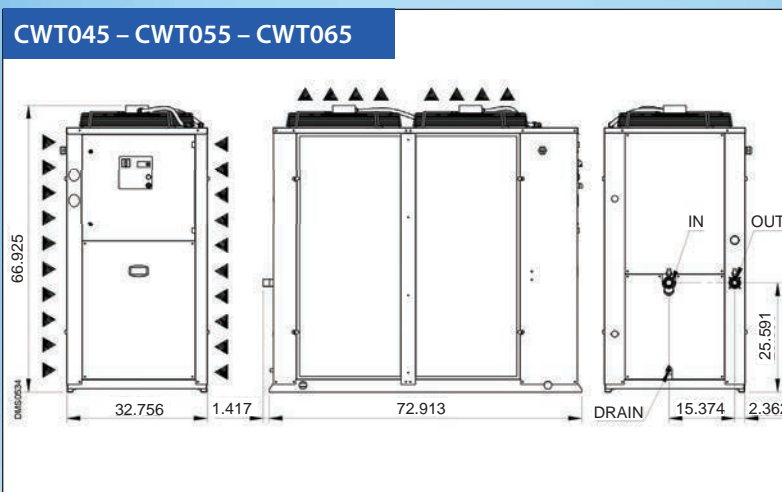
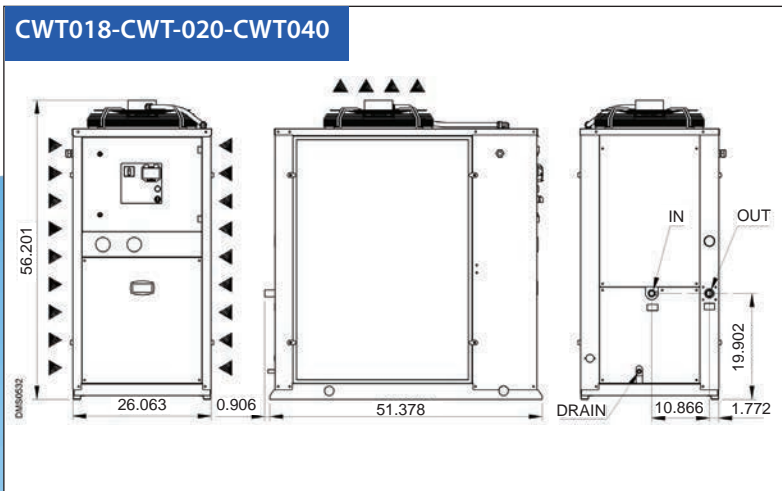
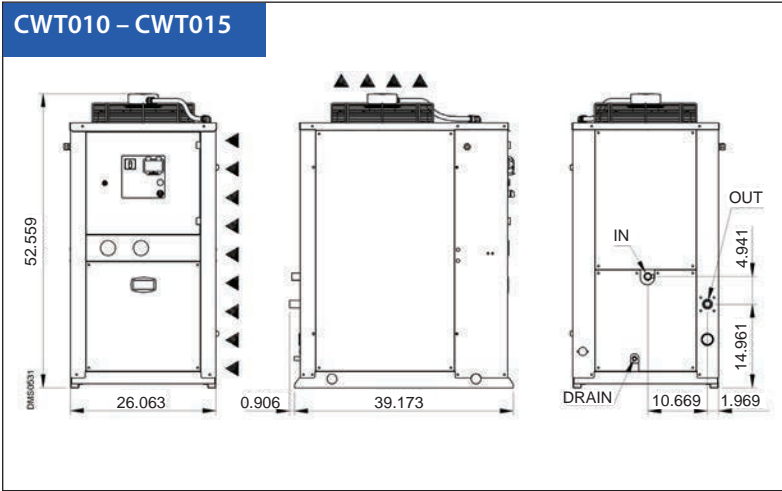

DIMENSIONAL DATA CONTINUED (All Data In Inches)

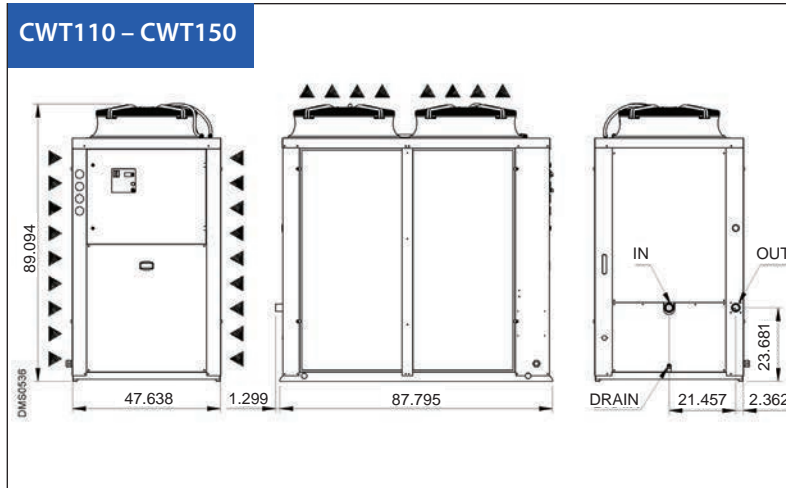

PURESTREAM CHILLER QUOTE REQUEST	
Contact Name	
Company Name	
Phone Number	
Email Address	
Address	
Province	
CHILLER REQUIREMENTS	(Please provide as much information as possible)
Application	
Indoor/Outdoor use	
Capacity Btuh's (Ton or KW)	
Entering chiller temperature	
Leaving chiller temperature	
Ambient Temperature	
Flow USGPM	
Power Requirements	
Pump PSI	
Fluid to be cooled	
Water %	
Glycol %	
Other %	

PURESTREAM

CHILLER SERIES

Made in Italy



Air-Cooled Chillers From 1/2 ton to 40 ton



Water Cooled Chillers 10 ton (Modular Design)

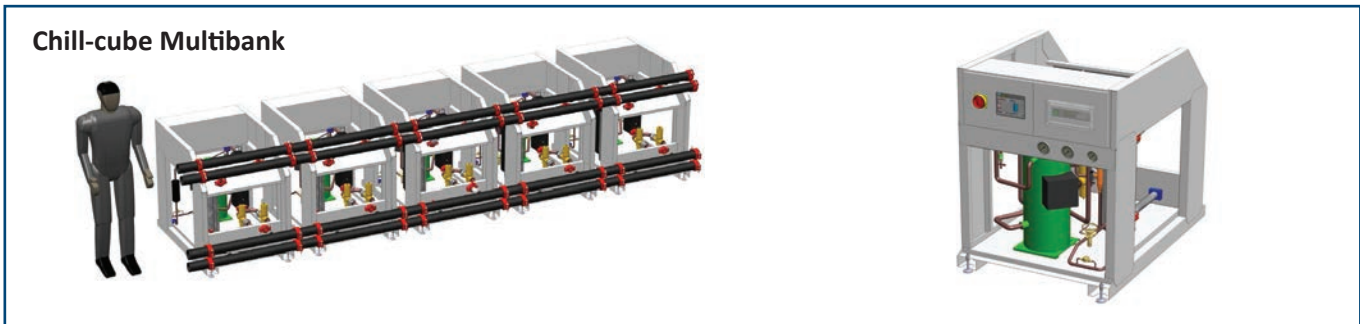

**Spot Coolers: Portable
Water & Air Cooled Solutions
Dehumidifiers**

CAG COOLING SOLUTIONS
 (A Division of CAG Purification)
 3770B Laird Road, Mississauga, ON. L5L 0A7
 Tel: 800-951-0777
 Fax: 905-820-3490
 chillers@cagcooling.com
www.cagcooling.com



**Chilled Water
Quick Connect Piping**